



Staff Report

PLANNING DIVISION
DEPARTMENT of COMMUNITY and NEIGHBORHOODS

To: Salt Lake City Planning Commission
From: Aaron Barlow, Principal Planner, aaron.barlow@slcgov.com, 801-535-6182
Date: April 26, 2023
Re: PLNPCM2022-00068, PLNPCM2022-00349, PLNSUB2023-00493
Brooklyn Avenue Street Vacation, Alley Vacation, and Subdivision Amendment

Street Vacation, Alley Vacation, and Subdivision Amendment

PROPERTY ADDRESS: Within the vicinity of 1005 & 1007 South 500 West
PARCEL IDs (of adjacent property): 15-12-327-001-0000 & 15-12-326-005-0000
MASTER PLAN: [Downtown Master Plan](#) & [Ballpark Station Area Plan](#)
ZONING DISTRICT: [CG General Commercial District](#)
COUNCIL DISTRICT: District 5: Darin Mano

REQUEST:

Jonah Hornsby of Jodah One, LLC has submitted the petitions listed below. The intent of these requests is to vacate a segment of Brooklyn Avenue adjacent to his property located at 1007 South 500 West (see maps included in [Attachment A](#)).

1. **Street Vacation (PLNPCM2022-00068)** – A request to vacate the roughly 85-foot-wide segment of Brooklyn Avenue between 500 West and the State-owned West Temple Viaduct right of way.
2. **Alley Vacation (PLNPCM2022-00349)** – A request to vacate the 13.25-foot-wide alley that bisects 1007 South 500 West between Brooklyn Avenue and the State-owned West Temple Viaduct right of way.
3. **Subdivision Amendment (PLNSUB2023-00493)** – A Preliminary Plat amending portions of the Brooklyn and Dolan Subdivisions and vacating the parts of Brooklyn Avenue that were dedicated by those subdivisions.

If approved, this section of Brooklyn Avenue would be divided and sold to the property owners of 1005 & 1007 South 500 West according to the approved plat at fair market value. Mr. Hornsby has made this request because he claims there is a lack of maintenance and issues with public safety. The requested vacations are also in anticipation of future development of the adjacent properties.

RECOMMENDATION:

Based on the information and findings listed in the staff report, Planning staff finds that, with the recommended conditions, the request generally meets the applicable standards and considerations. Therefore, staff recommends that the Planning Commission forward a positive recommendation regarding the request to the City Council with the following conditions:

- Before a final plat is recorded, the applicant will record a 15-foot-wide perpetual easement along the property lines abutting the storm sewer lines along the edge of the West Temple Viaduct right of way as directed by the Department of Public Utilities (as illustrated in the Exhibits included with [Attachment B](#)).
- After Brooklyn Avenue is officially vacated, city staff will record additional necessary sections of the easement within the vacated right of way prior to the official transfer of ownership to the applicant (as illustrated in the Exhibits included with [Attachment B](#)).
- The applicant will enter into an agreement with the City (through whatever method the City Council deems appropriate) that, upon any development of the Brooklyn Avenue right of way, they will install curb & gutter,

streetlights, and sidewalks along the property frontages of 500 West and Fayette Avenue according to Street Typology 8 (found in the [Street and Intersection Typologies Design Guide](#)):

- The applicant will enter into an agreement with the City (through whatever method the City Council deems appropriate) that, upon any development of the area within the Brooklyn Avenue right of way, they will install a turnaround that meets the fire code requirements at the time of development.
- On the Final Plat, the lot line dividing Lot 1 and Lot 2 shall be adjusted so that Lot 2 (1007 S 500 W) meets the minimum lot width requirement of 60 feet within the CG General Commercial Zoning District.

ATTACHMENTS:

- | | |
|---|---|
| A. Maps and Diagrams | F. Street Vacation Considerations |
| B. Applicant Submittal | G. Alley Vacation Standards |
| C. Property & Vicinity Photos | H. Subdivision Standards |
| D. Historical Aerial Photos | I. Public Process & Comments |
| E. Development Standards Review | J. Department Review Comments |

PETITION INFORMATION

This proposal includes three separate applications, each serving a specific purpose. Jonah Hornsby, the applicant, initially submitted the Street Vacation petition. Upon initial review of that request, Planning Staff determined that the other applications (the Alley Vacation and Subdivision Amendment applications) would also be necessary. Because Street Vacations petitions are not as common as other types of requests, Planning Staff has provided the following information to assist the Planning Commission with their decision and as information for the public.

What is a vacation?

A vacation is the removal of public interest in and ownership of a public right of way, like a street, trail, or alley. When a public right of way is vacated, it is either sold or transferred to private ownership. Only rights of way that are public and owned by Salt Lake may be vacated through this process. The two most common types of vacations that Salt Lake City deals with are Street Vacations and Alley Vacations. As their names imply, Street Vacations involve public streets, and Alley Vacations involve public alleys. Street Vacations are often confused with Street Closures. An approved Street Vacation eliminates a public right of way *and* transfers ownership to a private party, usually an adjacent property owner. A permanent Street Closure simply eliminates the public right of way, but the land underneath is still owned by the City (and the City may choose to lease that land to a private party). Since the applicant, Jonah Hornsby, has made a request to both close the public right of way and to purchase it, the request is a *Street Vacation*.

Why is an alley vacation necessary?

The property owned by the applicant (1007 S 500 W) is bisected by a public alley. While the alley in question has essentially been incorporated into the adjacent lots (and appears to have been that way for a significant amount of time), it is still owned by the city. According to Utah law, public rights of way can only be transferred to private ownership through a public process. If this Street Vacation request was approved without the associated Alley Vacation, the alley adjacent to Brooklyn Avenue would be isolated from the City's transportation network and unusable (if future City officials decided to reinstate the public's right to the alley). Neither Planning staff, nor the Planning Commission, can recommend the City Council approve vacating Brooklyn Avenue unless the adjacent alley is also vacated.

What is a Subdivision Amendment and why is it necessary?

A Subdivision Amendment, [according to Utah Code](#), is a proposed change to a recorded subdivision that does at least one of the following:

- Eliminates all or part of the subdivision,
- Changes the outside boundaries of the subdivision,
- Changes the number of lots in the subdivision,
- Changes or removes a public right of way or interest within the subdivision, or
- Changes or removes a common area or common amenity within the subdivision.

In this case, the request to vacate Brooklyn Avenue would remove public right of way from two subdivisions: the Brooklyn Subdivision and the Dolan Subdivision. It would also consolidate lots within the Brooklyn Subdivision. Because the applicant requested to vacate a public street, the subdivisions that designated the street in the first place must be amended.

Who has the Authority to approve the vacation of public streets and alleys?

[Title 20](#) of Salt Lake City Code, commonly referred to as Salt Lake City's "Subdivision Ordinance," and [Section 10-9a-609.5](#) of Utah State Code regulate Street Vacations within Salt Lake City. [Section 14.52](#) of Salt Lake City Code regulates Alley Vacations. In both cases, the Salt Lake City Council is the final decision-making authority. Both types of vacations also require a recommendation from the Planning Commission.

PROPOSAL DESCRIPTION

Background

In Early 2022, Jonah Hornsby, representing Jodah One, LLC, the property owner of 1007 South 500 West, submitted a request to vacate a section of Brooklyn Avenue between 500 West and the Utah Department of Transportation's (UDOT's) West Temple Viaduct right of way (see illustration below). His application cited a lack of maintenance, homeless encampments, and waste dumping as reasons for the request. The applicant has also indicated that, in the long term, he plans to develop the two adjacent properties, and vacating Brooklyn Avenue would improve the site's suitability for development.

Upon initial review of the Street Vacation Application, Planning Staff determined that the alley bisecting the applicant's property (1007 South 500 West) would also need to be vacated to avoid isolating public right of way. The applicant submitted a petition to do so a few months later.

Vacating a public street within a platted subdivision requires City Council approval of a Subdivision Amendment's Preliminary Plat. Brooklyn Avenue is located within both the Brooklyn and Dolan Subdivisions, so both must be amended. The applicant submitted a proposal to do so, which is included with this request. The nature of the Brooklyn Avenue right of way is discussed further in [Key Consideration 2](#).

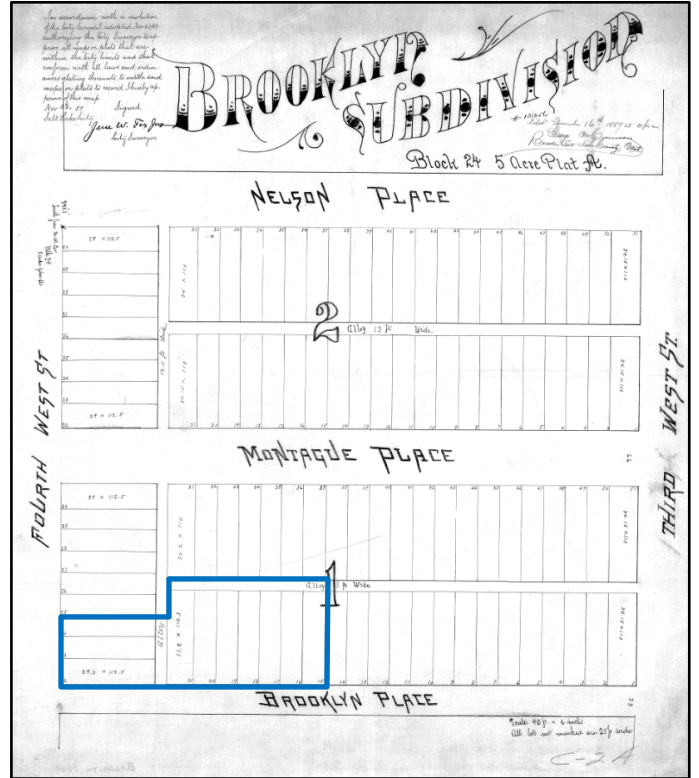

Original Brooklyn Subdivision with approximate location of 1005 South 500 West.

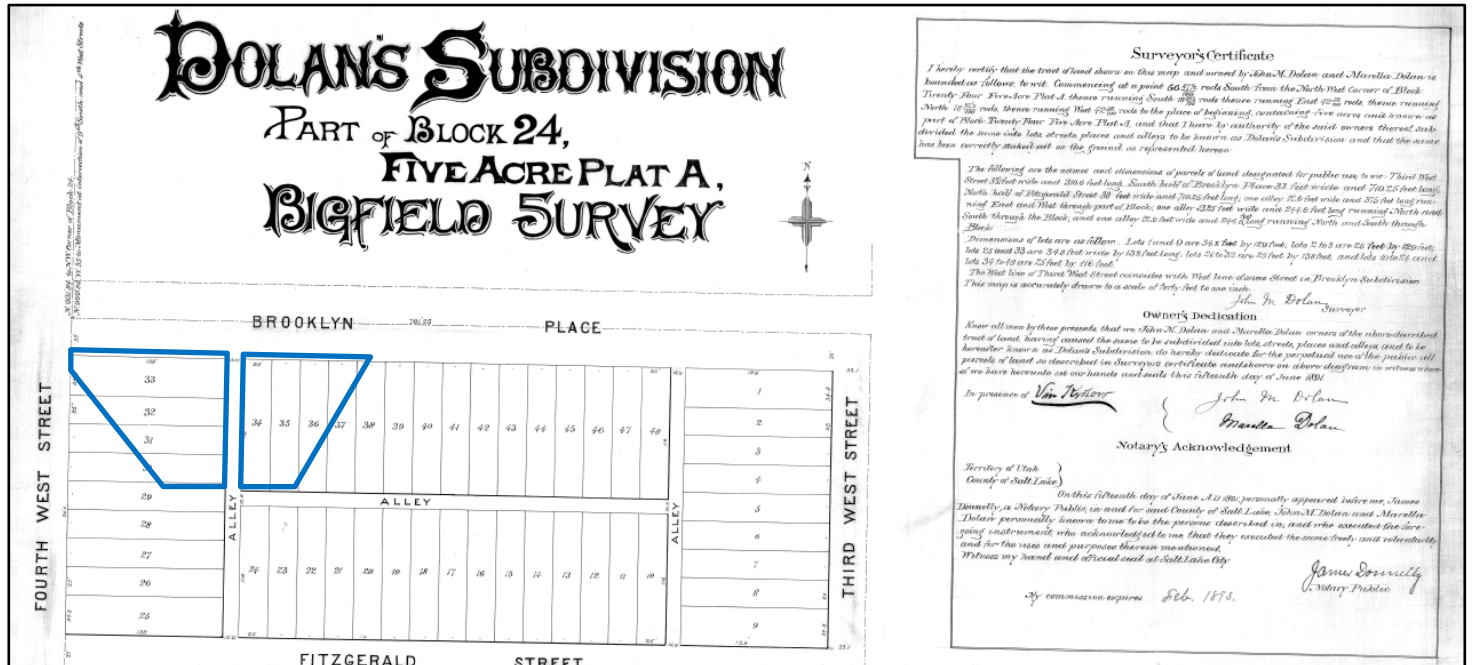

Original Dolan's Subdivision with approximate location of 1007 S 500 W. Much of this subdivision is now freeway right of way.

Brooklyn Avenue

The roughly 26,515-square-foot (0.61 acre) section of Brooklyn Avenue in question is approximately 198 feet long at the road center line and just under 85 feet in width. Based on historical aerial photographs, it appears the right of way has remained unimproved and unpaved since at least 1964, when I-15 was under construction. Brooklyn Avenue and the adjacent properties are located at the southernmost end of the Granary District (as established by the [Downtown Master Plan](#)). This part of the Granary District was separated from the Ballpark Neighborhood to the south and the Glendale Neighborhood to the west when I-15 and the West Temple Viaduct were initially constructed. Both 500 West and Brooklyn Avenue terminate near the applicants' properties. To the west, Fayette Avenue crosses under I-15, where 500 West continues south toward 1300 South. To the east, 400 West crosses under the Viaduct into the Ballpark Neighborhood near the Marq Townhomes.



Adjacent Alley

The adjacent alley that cuts through the applicant's property (1007 South 500 West) appears to have existed only on paper since at least 1937 based on staff analysis of historic aerial photography (included with [Attachment D](#)). Totalling approximately 1,450 square feet in area, the alley is roughly 109.5 feet long and 13.25 feet wide. The alley is only abutted by the applicant's property and terminates at the West Temple Viaduct right of way, which limits public access to only highway traffic.

Upon inspection of the site, Planning staff also found that the alley is blocked by a chain-link fence that surrounds the applicant's property and the alley, materially blocking it from public access.

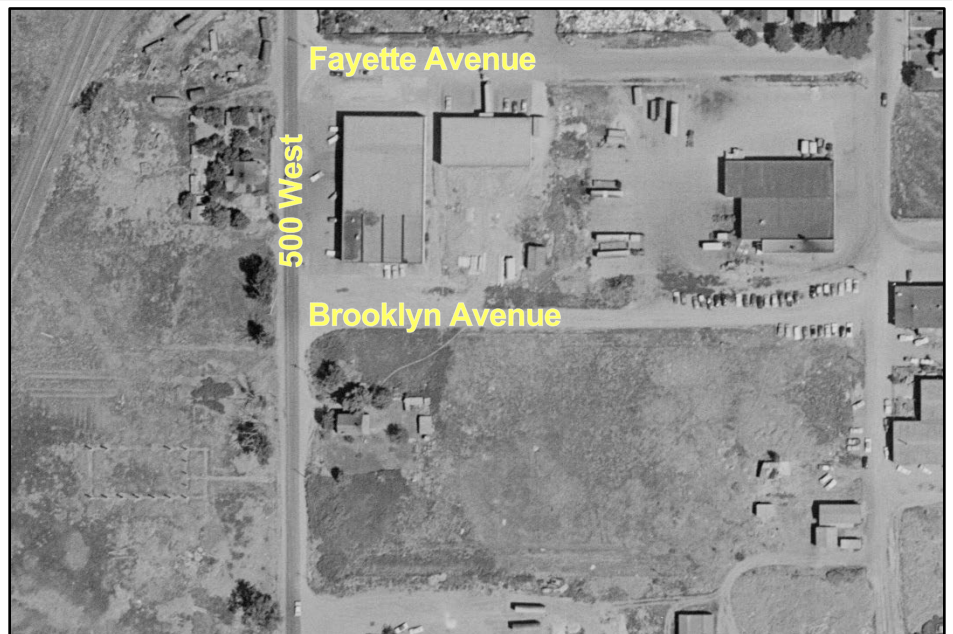

1958 Aerial of Brooklyn Avenue Vicinity. UGS Aerial Imagery Database.

Neighborhood and Vicinity Context

The character of the immediate vicinity consists of a mix of warehousing, manufacturing, and outdoor storage uses. As noted in the [Downtown Master Plan](#), the Granary District is characterized by its “primarily industrial uses and warehouse buildings.” While other areas to the north within the Granary District have seen significant investment and redevelopment, the state of the buildings and infrastructure show that the immediate vicinity of this portion of Brooklyn Avenue has not.

The surface of both Brooklyn Avenue and 500 West is in very poor condition. Sidewalks are nonexistent. On a map identifying areas within the Granary District in need of significant investment in new infrastructure (found on page 123), the Downtown Master Plan notes that segments of 500 West and Fayette Avenue that near this request have “very poor to marginal pavement conditions.” That map leaves out Brooklyn Avenue altogether.

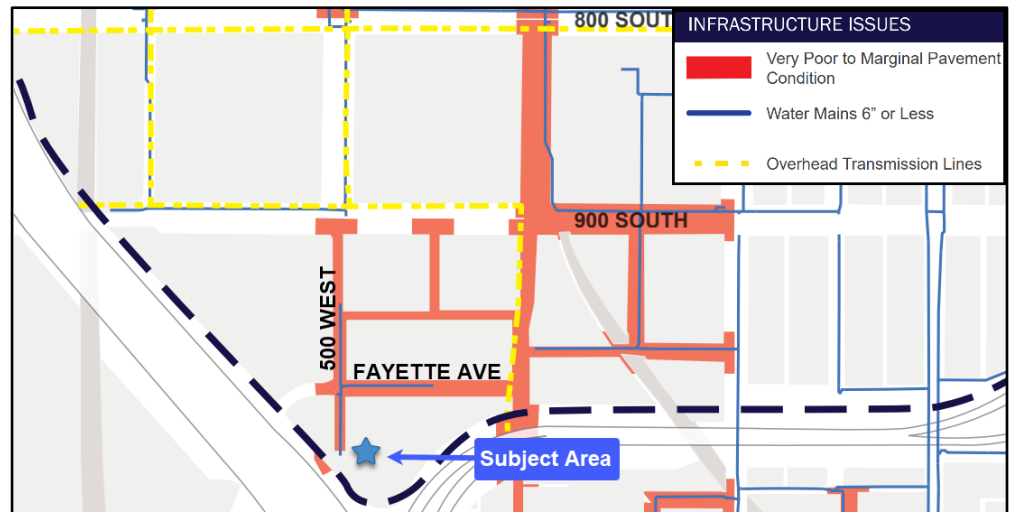

APPROVAL PROCESS AND COMMISSION AUTHORITY

Review Process: Street Vacation

Street Closures and Vacations are regulated by [Title 20 - Subdivisions](#) of Salt Lake City Code (commonly referred to as Salt Lake City’s “Subdivision Ordinance”) if they were dedicated by a platted subdivision. Street Closures are also regulated by [Section 10-9a-609.5](#) of Utah State Code. Analyses of all relevant factors are included with [Attachment F – Street Vacation Considerations](#).

The Planning Commission will make a recommendation to the City Council to approve or deny the application. Street Vacation requests are ultimately up to the City Council’s discretion and are not controlled by any one standard. If approved by the City Council, the area in question would be vacated, declared surplus property, and sold to the adjacent property owners for fair market value.

Review Process: Alley Vacation

Alley Vacation requests must fulfill one of four policy considerations found in section [14.52.020](#) of City Code: Lack of Use, Public Safety, Urban Design, or Community Purpose. Requests are also reviewed against the factors found in [14.52.030.B](#). Staff’s analysis of the policy considerations and factors can be found in [Attachment E – Alley Vacation Standards](#).

The Planning Commission will make a recommendation to the City Council to approve or deny the application. Alley Vacation requests are ultimately up to the City Council’s discretion and are not controlled by any one standard. If the Alley Vacation is approved, the City would sell half of the alley to the abutting property owners on each side (in this case the applicant owns the property on both sides of this alley. Any required easement would be established with the Salt Lake County Recorder’s office.

Review Process: Preliminary Plat, Subdivision Amendments Involving Streets

Subdivision Amendments involving streets are regulated by [Article III of Chapter 20.28 – Subdivision Amendments](#) of Salt Lake City Code. Preliminary Plats for subdivisions creating or vacating public right of way must be approved by the City Council. Approval of Subdivisions are subject to the standards found in [20.16.100 of the Subdivision Ordinance](#). Staff’s analysis of those standards can be found in [Attachment H](#).

The Planning Commission will make a recommendation to the City Council to approve or deny the Preliminary Plat application. Subdivision Amendments involving streets are ultimately up to the City Council’s discretion and are not controlled by any one standard. If the Preliminary Plat is approved, the associated Final Plat (and any other necessary documents as required) will be processed by Planning staff and signed by the Mayor before final recording at the Salt Lake County Recorder’s Office.

KEY CONSIDERATIONS

The following key considerations were identified based on Planning staff's analysis, feedback from other City departments, and public comment:

1. Conditions Requested by Other City Departments
2. Features of Brooklyn Avenue
3. State Code Regarding Street Vacations
4. Factors to Consider
5. Master Plan Compatibility
6. with Zoning Standards

Consideration 1: Conditions Requested by Other City Departments

The applicant worked with multiple City departments and divisions to discuss how to mitigate potential issues and negative impacts that would result from vacating Brooklyn Avenue. Representatives from Public Utilities, Engineering, Fire, and Transportation all brought up specific concerns with the request. The recommended conditions are the result of extensive negotiation between the applicant and City staff.

Public Utilities

In response to the proposal to vacate Brooklyn Avenue, representatives from the Public Utilities Department initially expressed opposition to the request. They noted that the street was necessary for access to their storm sewer facilities that run along the edge of the West Temple Viaduct right of way. In response, the applicant offered to provide an easement along the edge of the property. The applicant and the representatives from Public Utilities agreed on a 15-foot-wide easement on the applicants' properties along the edge of the viaduct right of way according to the following conditions:

- Before a final plat is recorded (which would vacate the street), the applicant will record a 15-foot-wide perpetual easement along the property lines abutting the storm sewer lines along the edge of the West Temple Viaduct right of way (as illustrated in the Exhibits included with [Attachment B](#)).
- After Brooklyn Avenue is officially vacated, city staff will record additional necessary sections of the easement within the vacated right of way prior to the official transfer of ownership to the applicant (as illustrated in the Exhibits included with [Attachment B](#)).

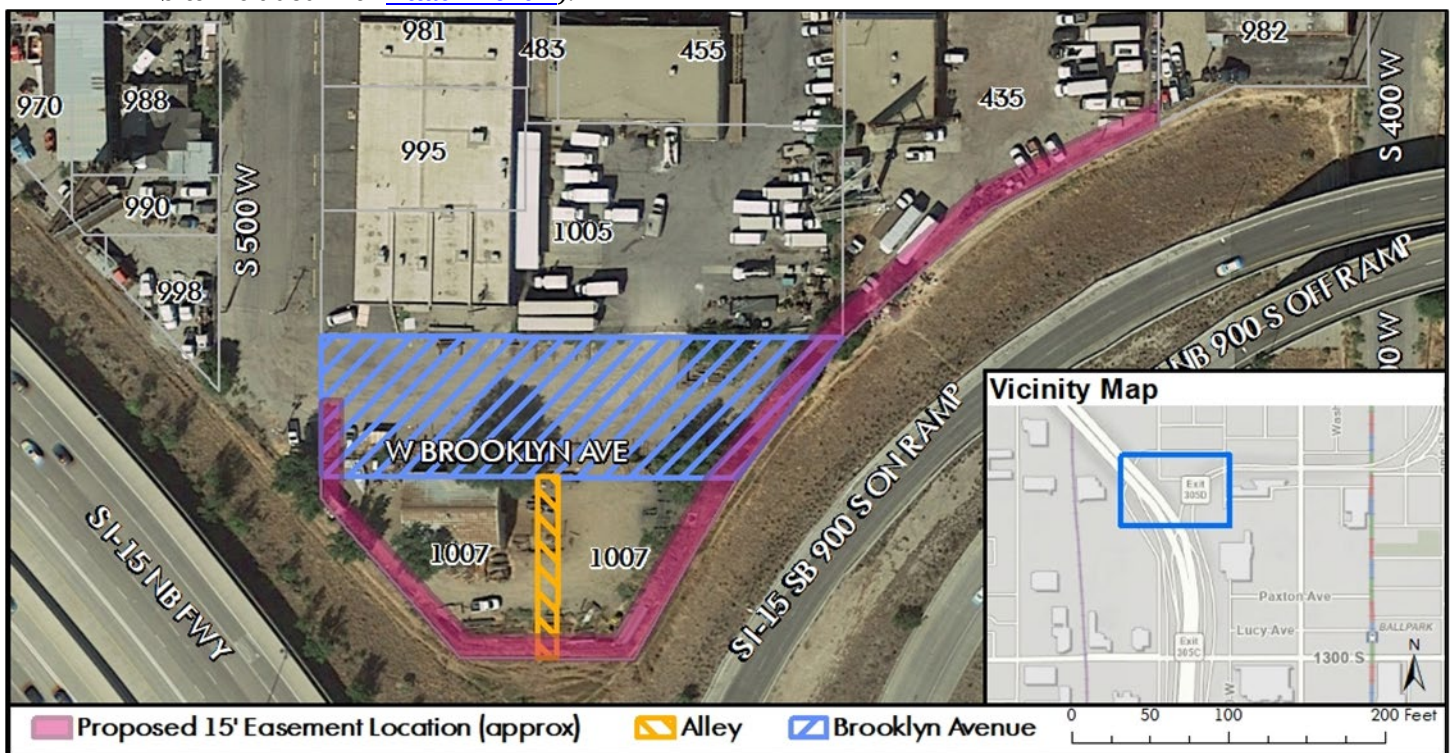

Engineering

Like many parts of the Granary District, both 500 West and Brooklyn Avenue lack basic street infrastructure. Surface materials are in disrepair, stormwater has nowhere to go, and pedestrian facilities are non-existent. While not specifically opposed to the request, City staff from the Engineering Division noted that, in many cases, basic street improvements (or an agreement to install such) are required prior to approval of a subdivision. However, further review by Planning and Engineering staff determined that plats that do not create new lots are not held to this requirement since they are not subdivisions. After meeting with Planning staff and the applicant, they determined that the following conditions would address their concerns:

- The applicant will enter into an agreement with the City (through whatever method the City Council deems appropriate) that, upon any development of the Brooklyn Avenue right of way, they will install curb & gutter, streetlights, and sidewalks along the property frontages of 500 West and Fayette Avenue according to Street Typology Type 8 (found in the [Street and Intersection Typologies Design Guide](#)). (Note: street trees are required for new commercial, mixed-use, and multifamily development)

Fire & Transportation

City staff representing both Transportation and Fire pointed out that vacating Brooklyn Avenue would leave 500 West without a place for fire trucks and other large trucks to turn around. State Fire Code requires that any dead-end roads longer than 150 feet and necessary for fire truck access must have a turnaround that complies with a design specified by the code (see below). After meeting with City staff, the applicant agreed to the following condition of approval:

- The applicant will enter into an agreement with the City (through whatever method the City Council deems appropriate) that, upon any development of the Brooklyn Avenue right of way, they will install a turnaround that meets the fire code requirements at the time of development. The diagrams below are turnaround designs permitted by State Fire Code.



Cross-section of Street Typology 8

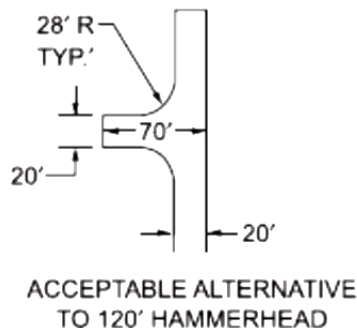
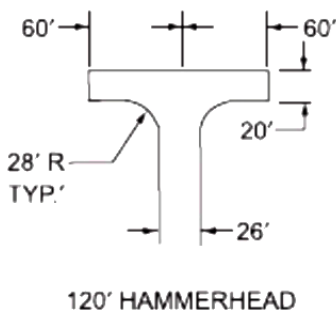
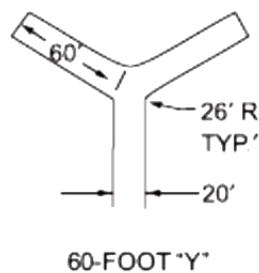
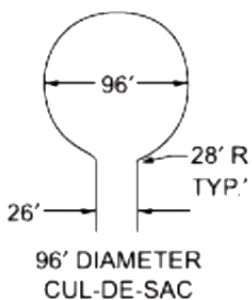

Consideration 2: Features of Brooklyn Avenue

Brooklyn Avenue is a unique stretch of public road because it was established through three different processes. The north 33 feet of the street was platted by the Brooklyn Subdivision and the south 33 feet by the Dolan Subdivision. The remaining ~21 feet of the roughly 87-foot-wide right of way remains part of the original Block 24 of the 5-acre Big Field Survey Plat “A,” meaning it is not located within a subdivision. Planning staff worked with the City Surveyor to determine how the street ended up with these Oreo cookie-like characteristics but could not come to a definitive conclusion. The best guess is that there was an error when either the Dolan or Brooklyn subdivisions were measured and established, leaving the gap.

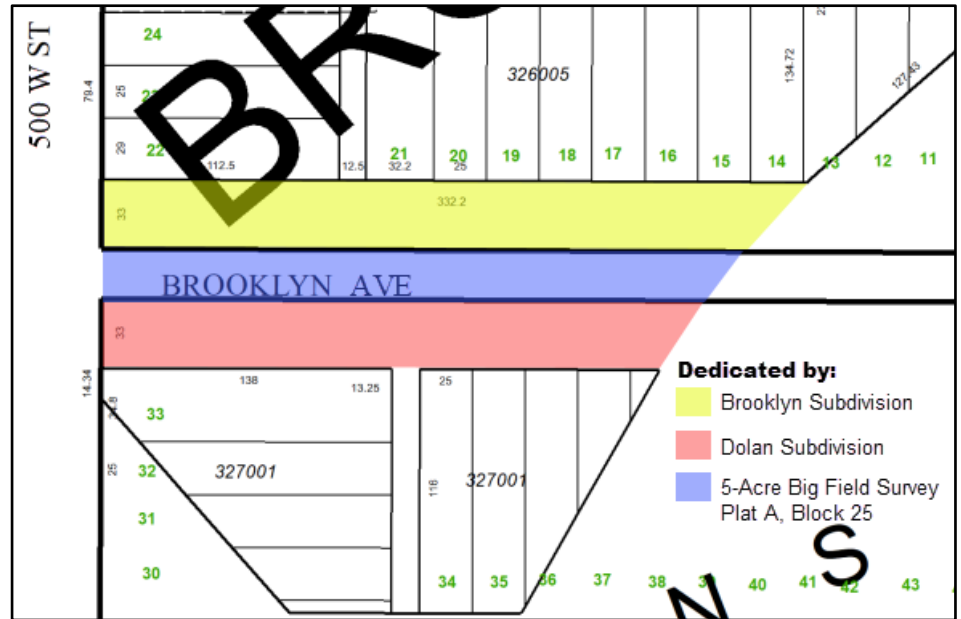

Salt Lake County Plat Map of Brooklyn Avenue right of way

Consideration 3: State Code Regarding Street Vacations

[Section 10-9a-609.5 of the Utah Code](#) Annotated establishes the power for cities to vacate streets upon the request of the governing body or a property owner. The City Council must determine that good cause exists for the vacation, and neither the public interest nor any person will be materially injured by the vacation. Aerial imagery shows that this section of Brooklyn Avenue has not been maintained since at least 1964 and is much wider than a typical local street. The vacation and Sale of this right of way will take a maintenance burden from the City for market-rate compensation.

Consideration 4: Factors to Consider

This request to vacate Brooklyn Avenue and the adjacent alley required three different types of applications, with separate applicable factors or standards. While decisions by the City Council are not held to any particular standard, recommendations from the Planning Commission must be made according to those applicable factors or standards. The standards for Street Vacations, Alley Vacations, and Subdivision amendments are listed in the [Approval Process and Commission Authority](#) section of this report.

Consideration 5: Master Plan Compatibility

Downtown Master Plan (2016)

The [Ballpark Station Area Plan](#) defers all long-range planning of the Granary District (where the alley is located) to the [Downtown Master Plan](#). The Downtown Master Plan places this section of Brooklyn Avenue, the alley, and the adjacent properties within the Granary District planning area. While the plan does not specifically address Alley or Street Vacations, it does include a robust discussion about mid-block walkways and connectivity. The plan identifies numerous proposed locations for future mid-block connections. However, those proposed connections are notably absent from the area surrounding this chunk of Brooklyn Avenue. Because of the immediate proximity of I-15 and the West Temple Viaduct, this part of the Granary District likely did not have the same opportunities for connectivity as areas farther north and east. There are no goals, initiatives, or objectives in the Downtown Master Plan that would explicitly prohibit vacating Brooklyn Avenue or the adjacent alley. Staff finds that this proposal neither supports nor violates any policy or goal found in the Downtown Master Plan.

Plan Salt Lake (2015)

Like the Downtown Master Plan, Initiative 8 of Plan Salt Lake’s Guiding Principle 8, Beautiful City, recommends “increased connectivity through mid-block connections.” While the plan does not identify specific locations, as with the Downtown Plan, it does encourage the use of existing alleys and other public rights of way for pedestrian connections. Brooklyn Avenue and the adjacent alley are isolated from other rights of way by the freeway and viaduct.

New pedestrian connections at this location are highly unlikely, given the circumstances. Vacating Brooklyn Avenue and the adjacent alley would not be out of line with any initiatives within Plan Salt Lake.

Transportation Major Street Plan (2018)

The Salt Lake City Transportation Master Plan’s [Major Street Plan \(2018\)](#) designates Brooklyn Avenue as a Local Street. The plan describes these types of streets as “usually one lane in each direction meant to carry traffic over short distances and at low speeds.” Brooklyn Avenue is significantly wider than a single lane in each direction. Vacating it would not impact the stated purpose of Local Streets, nor would it interfere with the city’s street network.

Transportation Master Plan (1996)

The last time Salt Lake City adopted a transportation master plan was in 1996. While that plan does not speak directly to street or alley vacations, it does contain relevant guiding principles. The first of those principles states that “*Salt Lake City’s transportation system will support and encourage the viability and quality life of its residents and business neighborhoods.*” According to the applicant, Brooklyn Avenue has become a popular spot for dumping, crime, and encampments. The street has not been paved since I-15 was constructed and is far too wide for its context. Vacating Brooklyn Avenue would not be contrary to the policies adopted in the Salt Lake City Transportation Master Plan.

The Transportation Division is currently working on an [updated Transportation Master Plan](#) (which was recently reviewed by the Planning Commission). While not yet adopted, the document will likely guide City Council discussions regarding this request. That draft plan contains two action items related to street and alley vacations:

- Value street and alley vacations
- Require midblock pathways.

The discussions for both items do not explicitly oppose vacations. Instead, the plan encourages that approved vacations should be appropriately valued and that a comparable public benefit should be considered in exchange for a vacation. The right of way that is proposed to be vacated already lacks connectivity because of the adjacent freeway right of way. Neither are ideal candidates for mid-block walkway crossings. However, the proposed access easement negotiated by the applicant and Public Utilities staff can be considered a community benefit. This easement will provide improved access to stormwater lines located along the edge of the freeway right of way. In Planning staff’s opinion, the proposed updated Transportation Master Plan supports this request even more than the existing plan.

Consideration 6: Compliance with Zoning Standards

One standard of approval for Preliminary Plats requires that “all buildable lots comply with all applicable zoning standards. Staff’s analysis of the Preliminary Plat for the proposed Subdivision Amendment found that all zoning standards were met except for one: minimum lot width in the CG General Commercial Zoning District.

As proposed, approval of the amendment would leave the south property (1007 South 500 West) with a lot width of approximately 55 feet. The minimum in the CG district is 60 feet. As a condition of approval, Planning Staff recommends that, on the Final Plat (the document that will officially establish the street vacation and new property lines), the new lot line dividing the north and south properties must be adjusted to ensure that the south property meets the minimum lot width. All other relevant zoning standards are met by this proposal.

NEXT STEPS

The Planning Commission can provide a positive or negative recommendation for the proposal and as part of a recommendation, can add conditions or request that changes be made to the proposal. The recommendation and any requested conditions/changes will be sent to the City Council, who will hold a briefing and a public hearing on the Street Vacation, Alley Vacation, and Subdivision Amendment requests. The City Council may make modifications to the proposal prior to approval of the requests.

If the requests are ultimately approved by the City Council, the applicant would need to meet all applicable conditions before an ordinance can be published. Once all conditions are met and the ordinance published, the Real Estate Services Division will negotiate a fair market value with the owners of the adjacent properties (who are also the applicants) prior to the sale of the vacated property.

If the request is not approved by the City Council, Brooklyn Avenue and the adjacent alley will remain. No right of way would be closed, and no real estate transactions would take place.

ATTACHMENT A: Maps and Diagrams



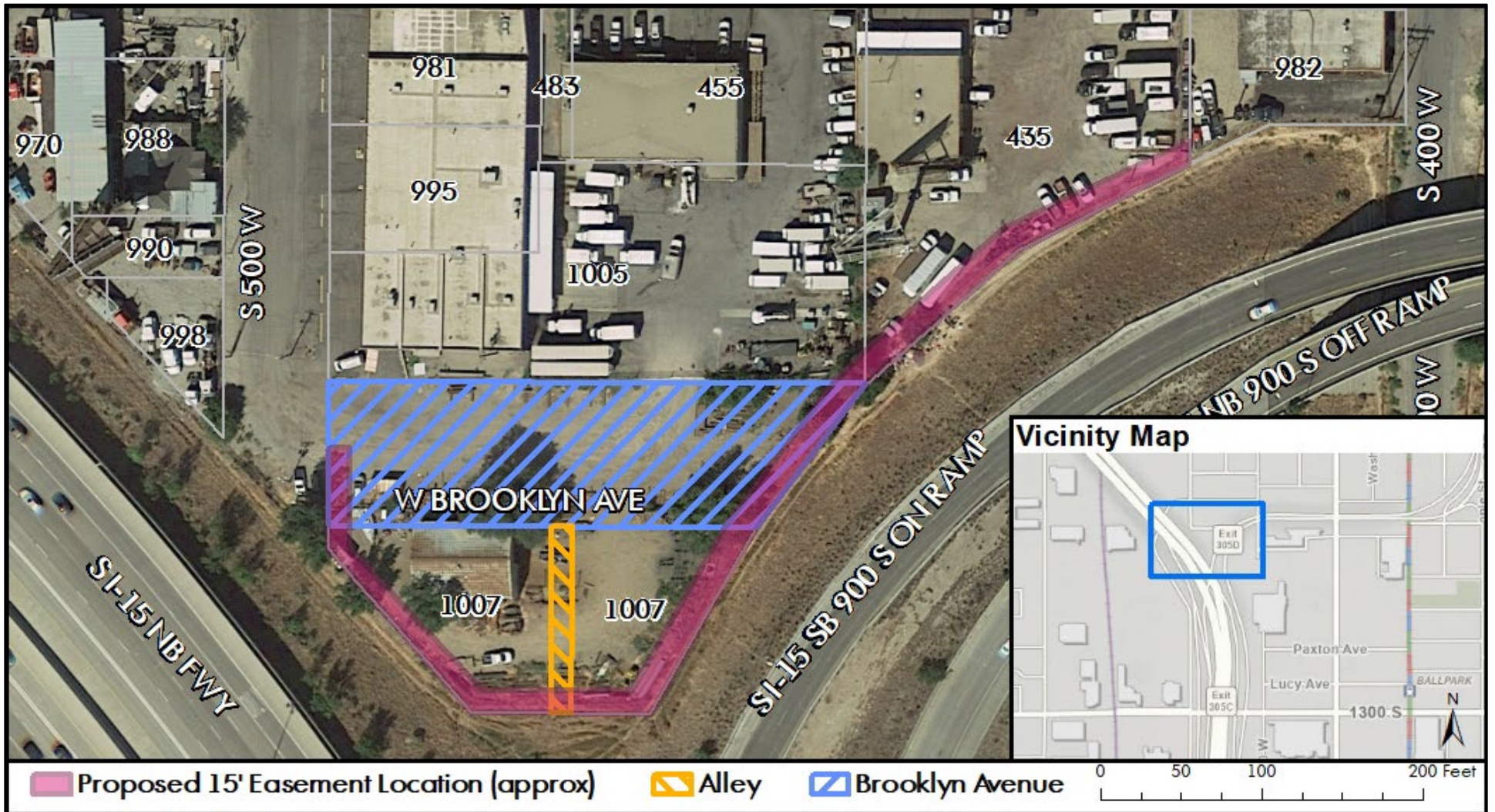

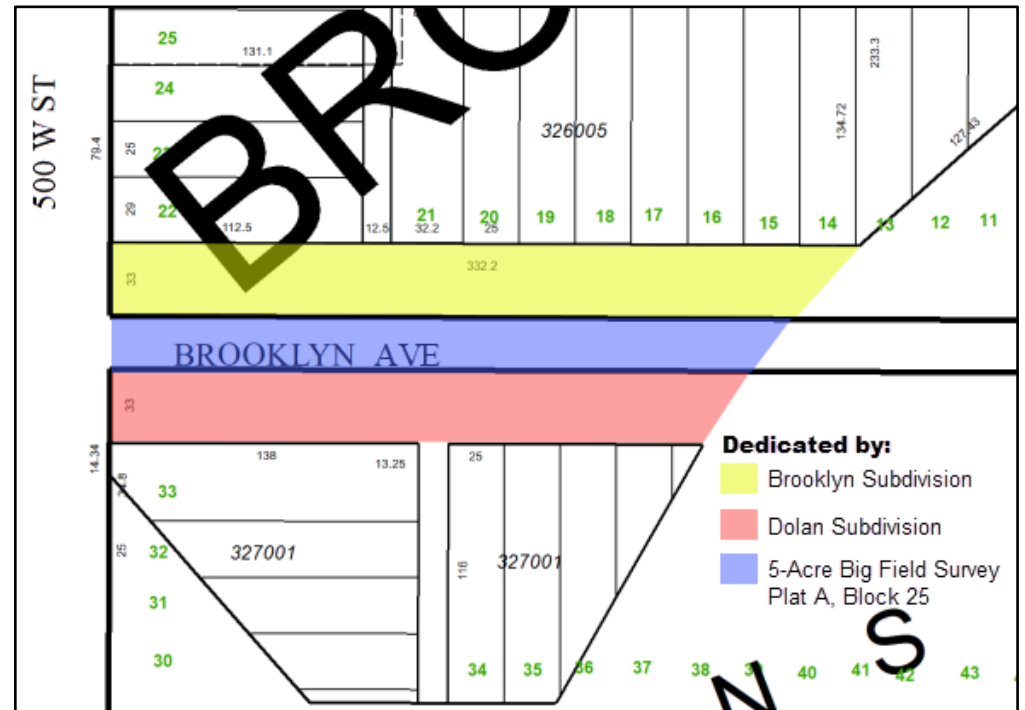
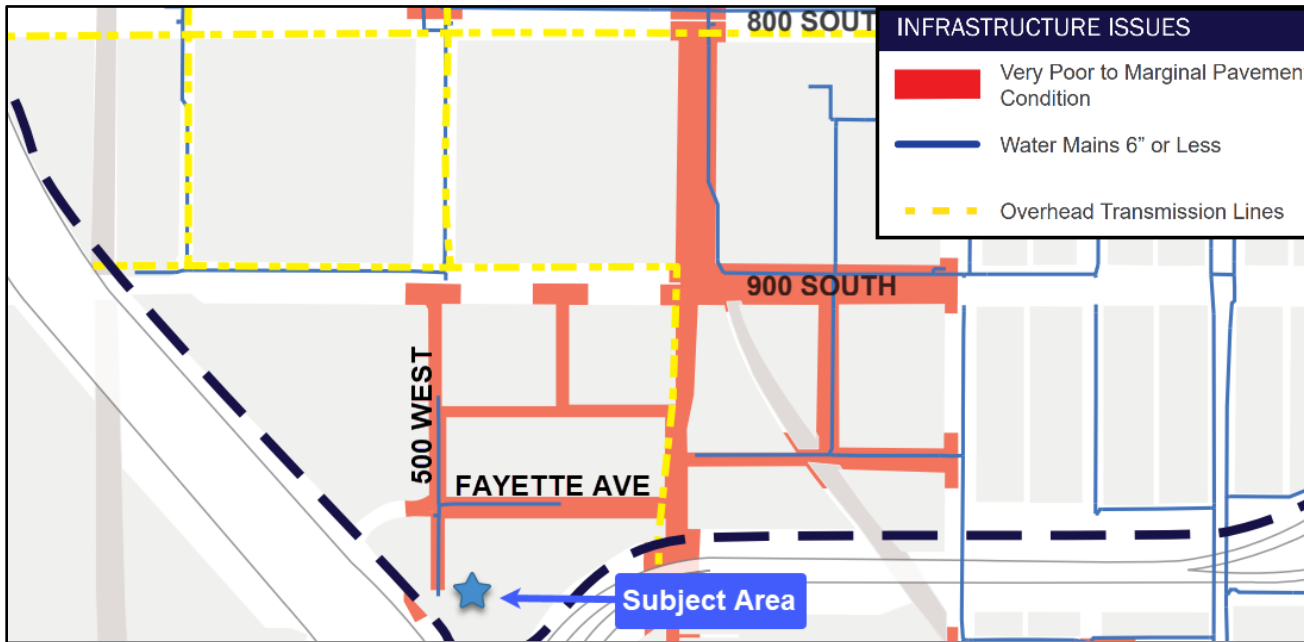

In accordance with a resolution of the City Council, adopted Nov 2, 1889 authorizing the City Surveyor to set from all maps or plats that are within the City limits and that conform with all laws and ordinances relating thereto, to settle said maps or plats to record, I hereby of
 Nov 22, 89
 City Surveyor

Signed
 James W. Fox Jr.
 City Surveyor

BROOKLYN SUBDIVISION

13426
 Filed June 16th 1889 at
 City of Brooklyn
 Recorder of Deeds

Block 24 5 Acre Plat A.

NELSON PLACE

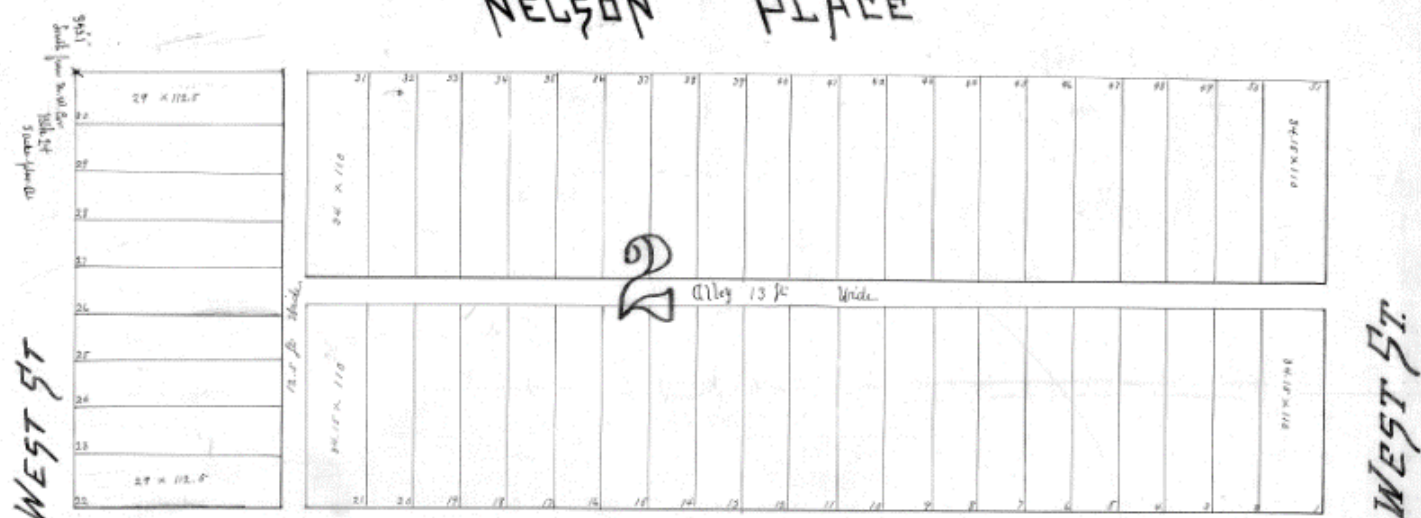

MONTAQUE PLACE

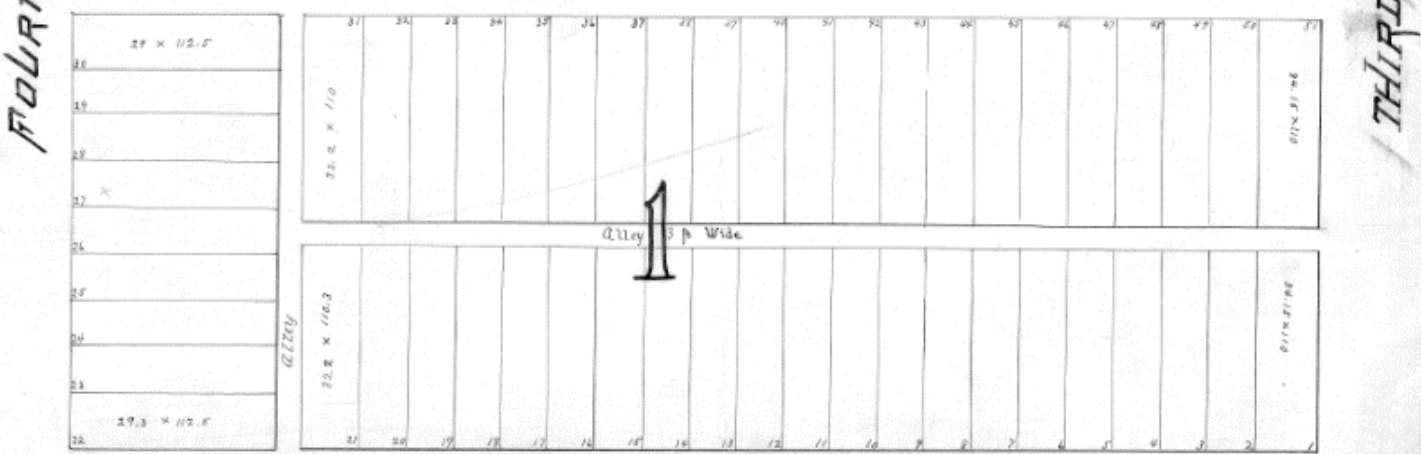

BROOKLYN PLACE

Scale 40 ft = 1 inch
 All lot and market are 25 ft wide

C-24

DOLAN'S SUBDIVISION

PART OF BLOCK 24, FIVE ACRE PLAT A, BIGFIELD SURVEY

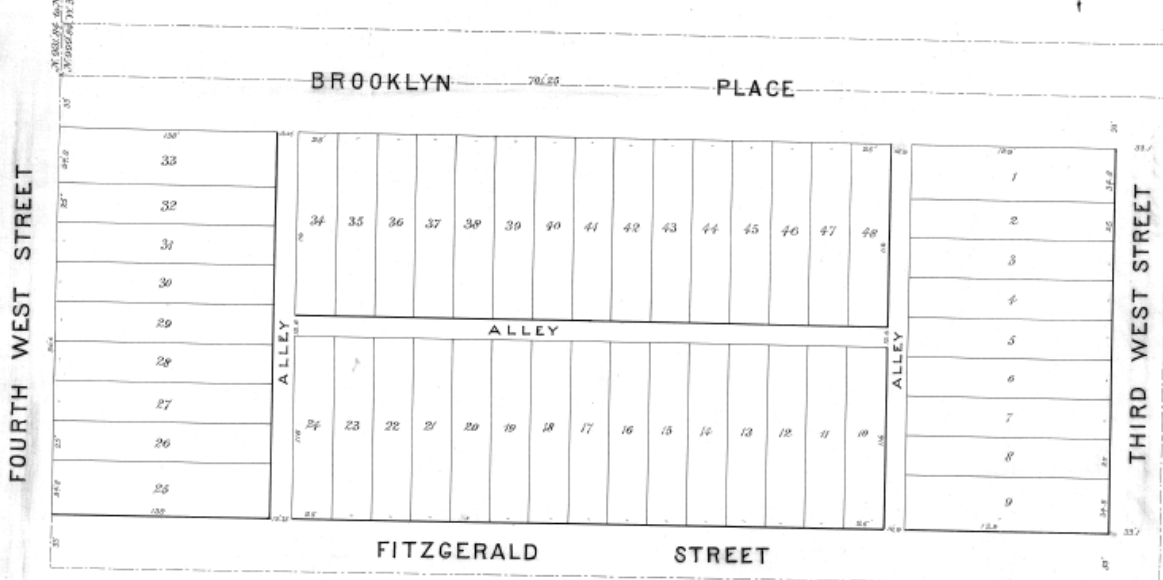

Surveyor's Certificate

I hereby certify that the tract of land shown on this map and owned by John M. Dolan and Marcelle Dolan is bounded as follows, to wit: Commencing at a point 56 2/5 rods South from the North West Corner of Block Twenty-Four Five-Acre Plat A, thence running South 88 1/2 rods thence running East 42 1/2 rods thence running North 12 1/2 rods thence running West 42 1/2 rods to the place of beginning, containing five acres and known as part of Block Twenty-Four Five-Acre Plat A, and that I have by authority of the said owners thereof subdivided the same into lots, streets, places and alleys to be known as Dolan's Subdivision and that the same has been correctly staked out on the ground as represented herein.

The following are the names and dimensions of parcels of land designated for public use to wit: Third West Street 35 feet wide and 300 feet long, South West of Brooklyn Place 33 feet wide and 710 2/5 feet long, North West of Fitzgerald Street 38 feet wide and 700 2/5 feet long, one alley 20 feet wide and 375 feet long running East and West through part of Block, one alley 25 feet wide and 274 6/7 feet long running North and South through the Block, and one alley 25 feet wide and 274 6/7 feet long running North and South through Block.

Dimensions of lots are as follow: Lots 1 and 9 are 56.5 feet by 120 feet, lots 2 to 8 are 25 feet by 120 feet, lots 25 and 33 are 37.8 feet wide by 133 feet long, lots 26 to 32 are 25 feet by 138 feet, and lots 34 to 48 are 25 feet by 116 feet.

The West line of Third West Street coincides with West line of same Street in Brooklyn Subdivision. This map is accurately drawn to a scale of forty feet to one inch.

John M. Dolan, Surveyor

Owner's Declaration

Know all men by these presents that we John M. Dolan and Marcelle Dolan owners of the above described tract of land, having caused the same to be subdivided into lots, streets, places and alleys, and to be hereafter known as Dolan's Subdivision, do hereby dedicate for the perpetual use of the public, all parcels of land as described in Surveyor's certificate and shown on above diagram, in witness whereof we have hereunto set our hands and seals this fifteenth day of June AD 1891.

In presence of *Van Houten* }
John M. Dolan
Marcelle Dolan

Notary's Acknowledgement

Territory of Utah }
 County of Salt Lake }

On this fifteenth day of June AD 1891, personally appeared before me, James Donnelly, a Notary Public, in and for said County of Salt Lake, John M. Dolan and Marcelle Dolan personally known to me to be the persons described in, and who executed the foregoing instrument, who acknowledged to me that they executed the same freely and voluntarily, and for the uses and purposes therein mentioned.

Witness my hand and official seal at Salt Lake City.

James Donnelly
 Notary Public

My commission expires Feb. 1893.

Filed July 10 1891 at 2:30 PM
John A. Reamed Jr
Recorder

Recorded to the City Council June 22 1891
 and City Engineer authorized to approve the same.

Approved June 20 1891.
A. S. Dornum
 City Engineer.

ATTACHMENT B: Applicant Submittal

This page is intentionally left blank.

BROOKLYN SUBDIVISION AMENDED

AMENDING LOTS 30-38 DOLANS SUBDIVISION, LOTS 14-38 OF BROOKLYN SUBDIVISION,
AND VACATING BROOKLYN AVENUE
LOCATED IN THE SOUTHWEST QUARTER OF SECTION 12,
TOWNSHIP 1 SOUTH, RANGE 1 WEST,
SALT LAKE BASE AND MERIDIAN.

NORTH

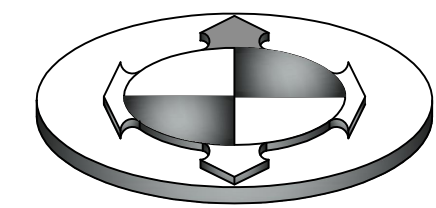

GRAPHIC SCALE

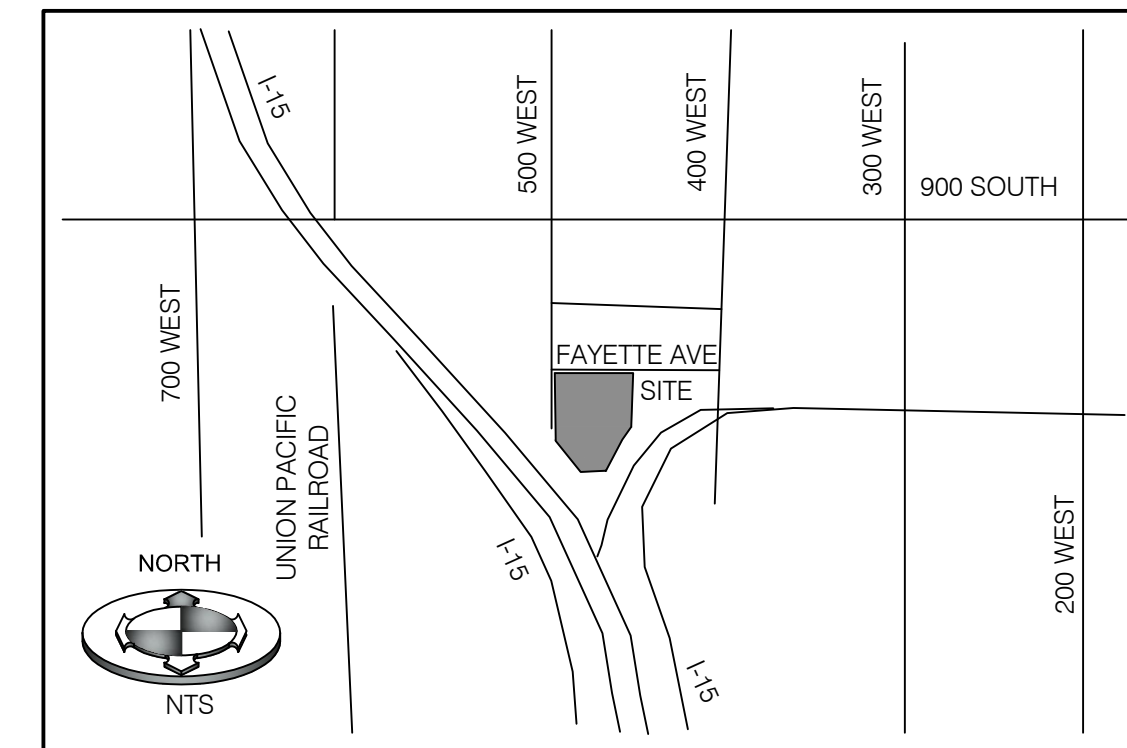
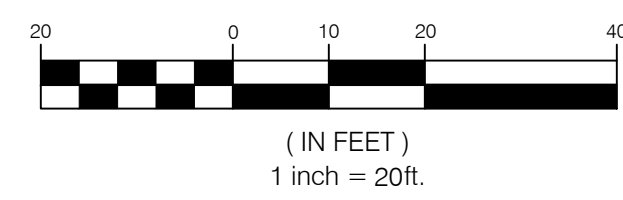

VICINITY MAP

LEGEND

- EX. BRASS CAP MONUMENT (RING & LID)
- STREET MONUMENT (NOT FOUND)
- BOUNDARY CORNER
(SET 1/8 REBAR AND CAP OR AS NOTED ON PLAT) 'STAMPED BENCHMARK ENG.'
- BOUNDARY LINE
- ADJACENT PROPERTY
- STREET MONUMENT LINE (EXISTING)
- LOT LINE
- ORIGINAL LOT LINES

LLC ACKNOWLEDGMENT

STATE OF UTAH }
County of Salt Lake } S.S.
ON THE ____ DAY OF _____ A.D., 2023, PERSONALLY APPEARED BEFORE ME _____, WHOSE IDENTITY IS PERSONALLY KNOWN TO ME (OR PROVEN ON THE BASIS OF SATISFACTORY EVIDENCE) AND WHO, BY ME DULY SWORN/AFFIRMED, DID SAY THAT HE/SHE IS A _____ OF JODAH ONE, L.L.C., A UTAH LIMITED LIABILITY COMPANY, AND THAT THE OWNER'S DEDICATION WAS SIGNED BY HIM/HER ON BEHALF OF SAID LLC, AND SAID _____, ACKNOWLEDGED TO ME THAT SAID LLC EXECUTED THE SAME.

MY COMMISSION EXPIRES: _____ (DATE) COMMISSION NUMBER: _____

PRINT NAME _____ NOTARY PUBLIC RESIDING IN _____ COUNTY

LLC ACKNOWLEDGMENT

STATE OF UTAH }
County of Salt Lake } S.S.
ON THE ____ DAY OF _____ A.D., 2023, PERSONALLY APPEARED BEFORE ME _____, WHOSE IDENTITY IS PERSONALLY KNOWN TO ME (OR PROVEN ON THE BASIS OF SATISFACTORY EVIDENCE) AND WHO, BY ME DULY SWORN/AFFIRMED, DID SAY THAT HE/SHE IS A _____ OF SLC REAL ESTATE INVESTMENTS, L.L.C., A DELAWARE LIMITED LIABILITY COMPANY, AND THAT THE OWNER'S DEDICATION WAS SIGNED BY HIM/HER ON BEHALF OF SAID LLC, AND SAID _____, ACKNOWLEDGED TO ME THAT SAID LLC EXECUTED THE SAME.

MY COMMISSION EXPIRES: _____ (DATE) COMMISSION NUMBER: _____

PRINT NAME _____ NOTARY PUBLIC RESIDING IN _____ COUNTY

NOTES:
1. THIS PLAT IS SUBJECT TO ANY EASEMENTS OR NOTES SHOWN ON BROOKLYN SUBDIVISION, RECORDED AS ENTRY NO. 13456 IN BOOK C AT PAGE 2 IN THE OFFICE OF THE SALT LAKE COUNTY RECORDER.
2. THIS PLAT IS SUBJECT TO ANY EASEMENTS OR NOTES SHOWN ON DOLANS SUBDIVISION, RECORDED AS ENTRY NO. 40995 IN BOOK C AT PAGE 120 IN THE OFFICE OF THE SALT LAKE COUNTY RECORDER.

SURVEYOR'S CERTIFICATE

I, BRIAN A. LINAM DO HEREBY CERTIFY THAT I AM A PROFESSIONAL LAND SURVEYOR, AND THAT I HOLD LICENSE NO. 7240531 IN ACCORDANCE WITH TITLE 58, CHAPTER 22, OF THE PROFESSIONAL ENGINEERS AND LAND SURVEYORS ACT. I FURTHER CERTIFY THAT BY AUTHORITY OF THE OWNERS I HAVE COMPLETED A SURVEY OF THE PROPERTY DESCRIBED ON THIS SUBDIVISION PLAT AND FILED SURVEY AS S 2022-05-0266 IN THE OFFICE OF THE SALT LAKE COUNTY SURVEYOR. IN ACCORDANCE WITH SECTION 17-23-17, HAVE VERIFIED ALL MEASUREMENTS, AND HAVE SUBDIVIDED SAID TRACT OF LAND INTO LOTS, TOGETHER WITH EASEMENTS, HEREAFTER TO BE KNOWN AS:

BROOKLYN SUBDIVISION AMENDED

AMENDING LOTS 30-38 DOLANS SUBDIVISION,
LOTS 14-38 OF BROOKLYN SUBDIVISION,
AND VACATING BROOKLYN AVENUE

AND THAT THE SAME HAS BEEN CORRECTLY SURVEYED AND STAKED ON THE GROUND AS SHOWN ON THIS PLAT.

BOUNDARY DESCRIPTION

A TRACT OF LAND LOCATED IN THE SOUTHWEST QUARTER OF SECTION 12, TOWNSHIP 1 SOUTH, RANGE 1 WEST, SALT LAKE BASE AND MERIDIAN, SAID TRACT OF LAND BEING MORE PARTICULARLY DESCRIBED AS FOLLOWS:

BEGINNING AT THE NORTH-WEST CORNER OF LOT 30, BLOCK 1, BROOKLYN SUBDIVISION, RECORDED AS ENTRY NO. 13456 IN BOOK C AT PAGE 2 IN THE OFFICE OF THE SALT LAKE COUNTY RECORDER, SAID POINT BEING SOUTH 00°01'01" EAST 33.00 FEET AND NORTH 89°56'40" EAST 35.00 FEET FROM THE STREET MONUMENT LOCATED AT THE INTERSECTION OF 500 WEST STREET AND FAYETTE AVENUE, AND RUNNING THENCE NORTH 89°56'40" EAST 332.17 FEET ALONG THE SOUTHERLY RIGHT OF WAY LINE OF FAYETTE AVENUE; THENCE SOUTH 00°01'01" EAST 233.30 FEET TO A POINT ON THE NORTHERLY RIGHT OF WAY LINE OF THE INTERSTATE - 15 OFF RAMP; THENCE ALONG SAID RIGHT OF WAY LINE THE FOLLOWING FIVE (5) COURSES: 1) SOUTH 38°49'11" WEST 63.51 FEET; 2) SOUTH 34°19'47" WEST 48.47 FEET; 3) SOUTH 30°40'07" WEST 127.73 FEET; 4) SOUTH 89°56'40" WEST 110.00 FEET; 5) NORTH 43°17'26" WEST 131.03 FEET TO A POINT ON THE EASTERLY RIGHT OF WAY LINE OF 500 WEST STREET; THENCE NORTH 00°01'01" WEST 337.08 FEET TO THE POINT OF BEGINNING.

CONTAINS: 125,312 SQ. FT. OR 2.877

BENCHMARK ENGINEERING & LAND SURVEYING

9138 SOUTH STATE STREET SUITE # 100
SANDY, UTAH 84070 (801) 542-7192
www.benchmarkcivil.com

TX ID #S:
15-12-327-001
15-12-326-001
15-12-326-002
15-12-326-003
15-12-326-004
15-12-326-005



OWNER'S DEDICATION

KNOW ALL MEN BY THESE PRESENTS THAT THE UNDERSIGNED ARE THE OWNER(S) OF THE ABOVE DESCRIBED TRACT OF LAND, AND HEREBY CAUSE THE SAME TO BE DIVIDED INTO LOTS, PARCELS AND STREETS, TOGETHER WITH EASEMENTS AS SET FORTH TO BE HEREAFTER KNOWN AS

BROOKLYN SUBDIVISION AMENDED

AMENDING LOTS 30-38 DOLANS SUBDIVISION,
LOTS 14-38 OF BROOKLYN SUBDIVISION,
AND VACATING BROOKLYN AVENUE

AND DO HEREBY DEDICATE FOR PERPETUAL USE OF THE PUBLIC ALL ROADS AND OTHER AREAS SHOWN ON THIS PLAT AS INTENDED FOR PUBLIC USE. THE UNDERSIGNED OWNER(S) HEREBY CONVEYS TO ANY AND ALL PUBLIC UTILITY COMPANIES A PERPETUAL, NON EXCLUSIVE EASEMENT OVER THE PUBLIC UTILITY EASEMENTS SHOWN ON THIS PLAT, THE SAME TO BE USED FOR THE INSTALLATION, MAINTENANCE AND OPERATION OF UTILITY LINES AND FACILITIES. THE UNDERSIGNED OWNER(S) ALSO HEREBY CONVEY ANY OTHER EASEMENT AS SHOWN AND/OR NOTED ON THIS PLAT TO THE PARTIES INDICATED AND FOR THE PURPOSES SHOWN AND/OR NOTED HEREON.

THIS ____ DAY OF _____, A.D. 20____.

KESSIMAKIS PROPERTIES, L.L.C. SLC REAL ESTATE INVESTMENTS, LLC

SIGNATURE SIGNATURE

JODAH ONE, L.L.C.

SIGNATURE

LLC ACKNOWLEDGMENT

STATE OF UTAH }
County of Salt Lake } S.S.
ON THE ____ DAY OF _____ A.D., 2023, PERSONALLY APPEARED BEFORE ME _____, WHOSE IDENTITY IS PERSONALLY KNOWN TO ME (OR PROVEN ON THE BASIS OF SATISFACTORY EVIDENCE) AND WHO, BY ME DULY SWORN/AFFIRMED, DID SAY THAT HE/SHE IS A _____ OF KESSIMAKIS PROPERTIES, L.L.C., A UTAH LIMITED LIABILITY COMPANY, AND THAT THE OWNER'S DEDICATION WAS SIGNED BY HIM/HER ON BEHALF OF SAID LLC, AND SAID _____, ACKNOWLEDGED TO ME THAT SAID LLC EXECUTED THE SAME.

MY COMMISSION EXPIRES: _____ (DATE) COMMISSION NUMBER: _____

PRINT NAME _____ NOTARY PUBLIC RESIDING IN _____ COUNTY

SIGNATURE

SIGNATURE

BROOKLYN SUBDIVISION AMENDED

AMENDING LOTS 30-38 DOLANS SUBDIVISION,
LOTS 14-38 OF BROOKLYN SUBDIVISION, AND VACATING BROOKLYN AVENUE
LOCATED IN THE NORTHEAST QUARTER OF SECTION 8,
TOWNSHIP 1 SOUTH, RANGE 1 EAST,
SALT LAKE BASE AND MERIDIAN

SHEET 1 OF 1

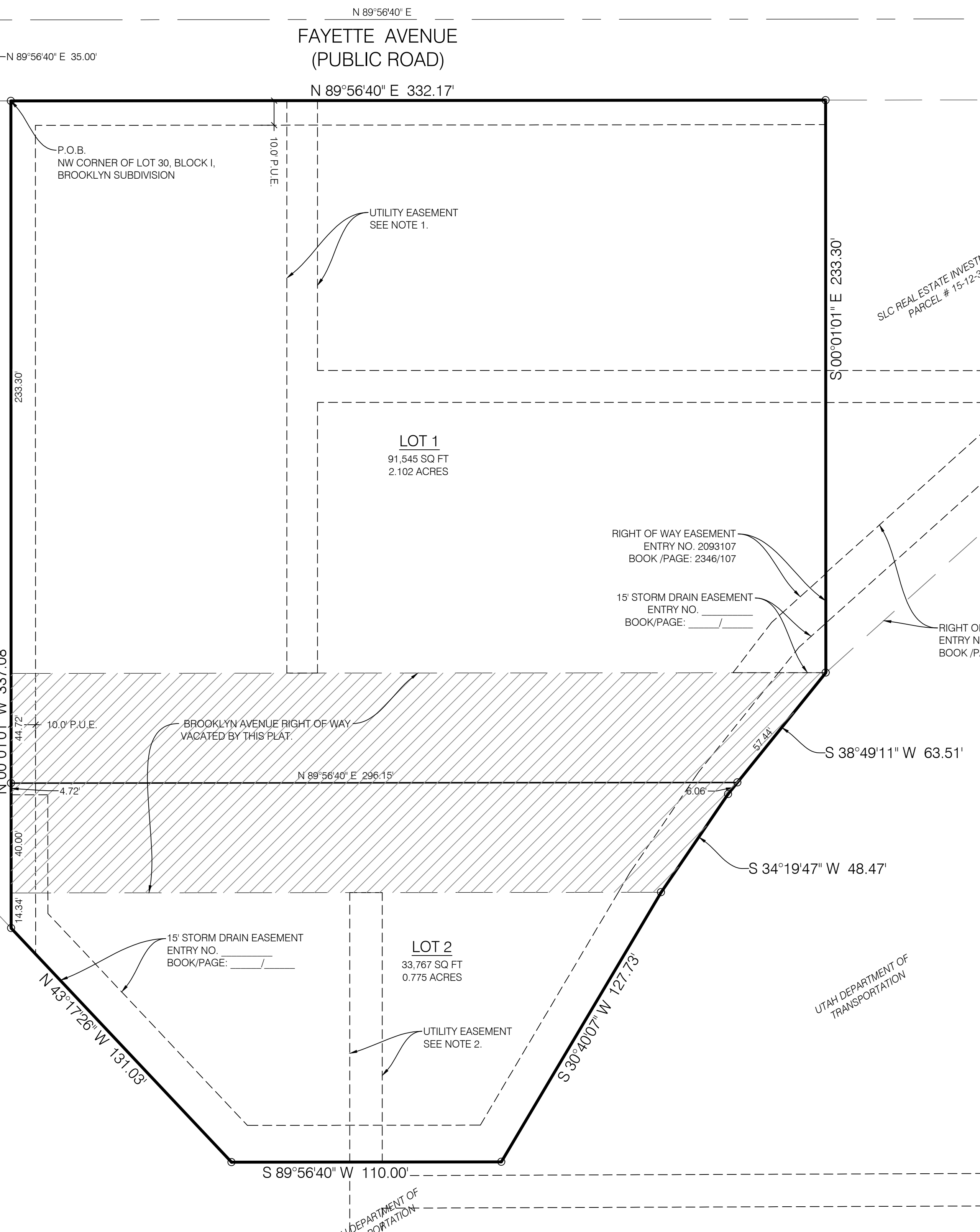
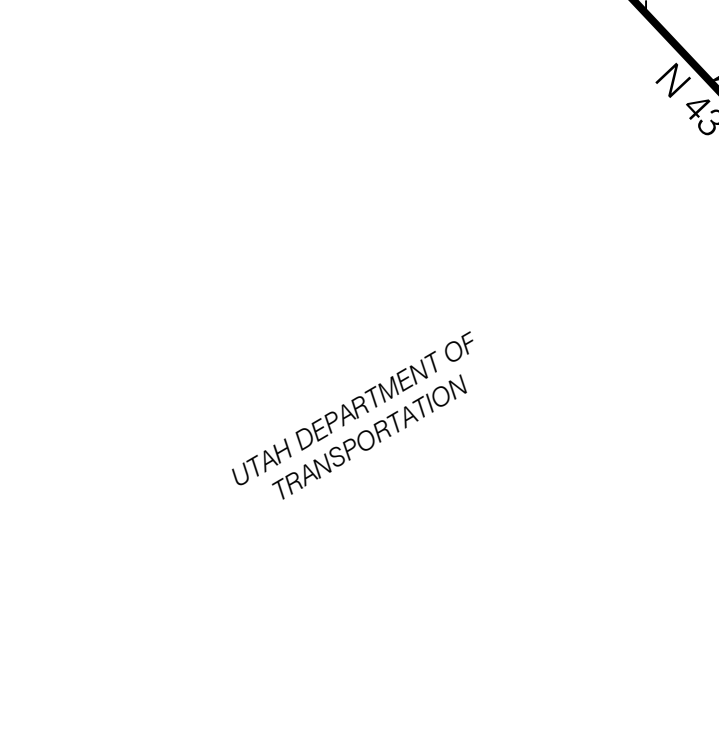
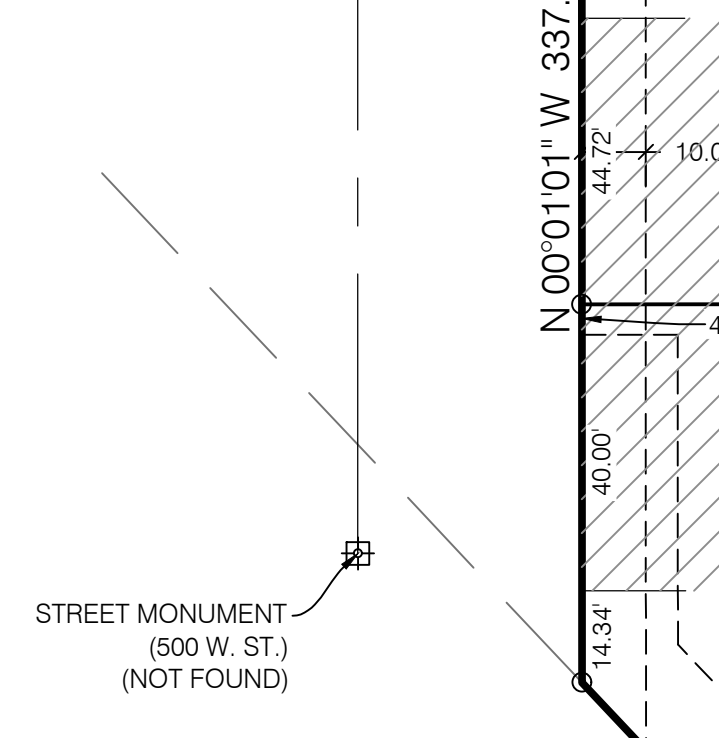
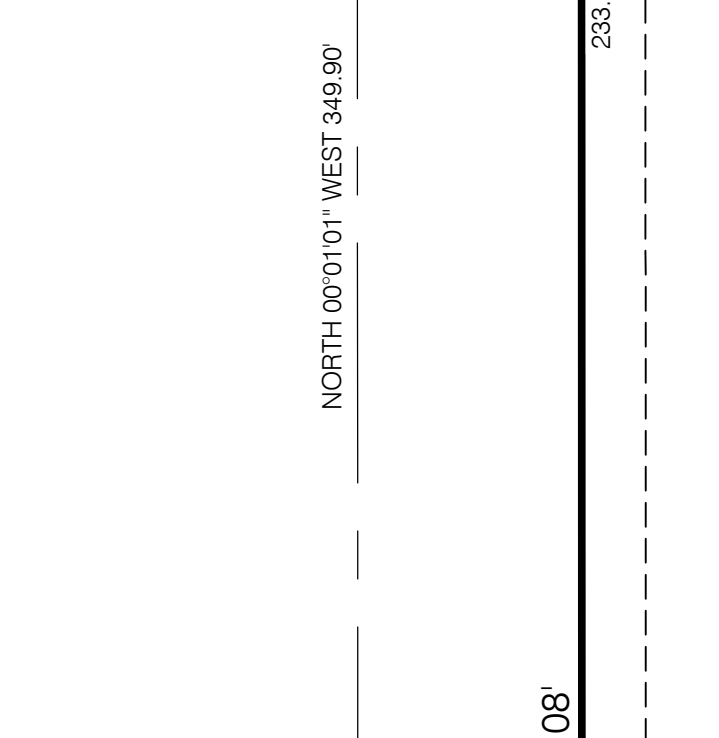
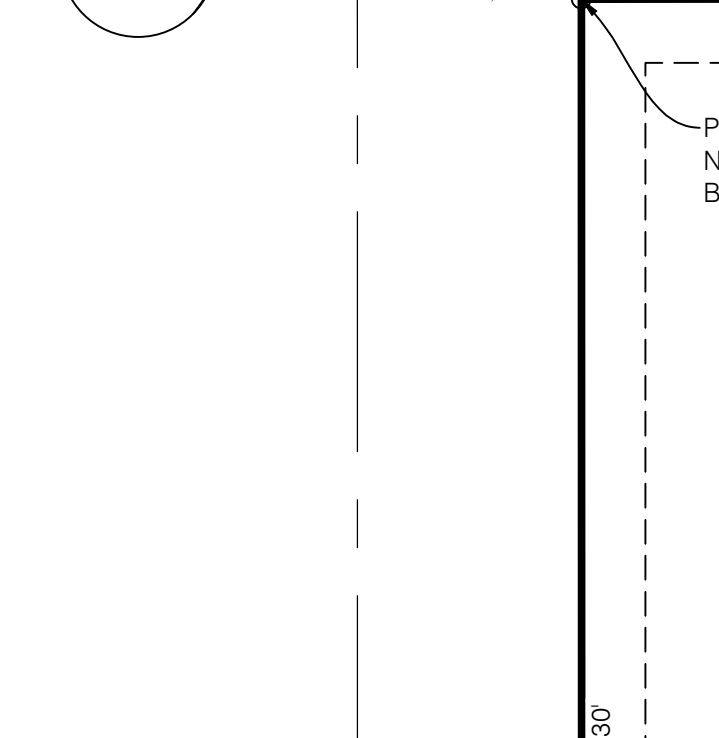
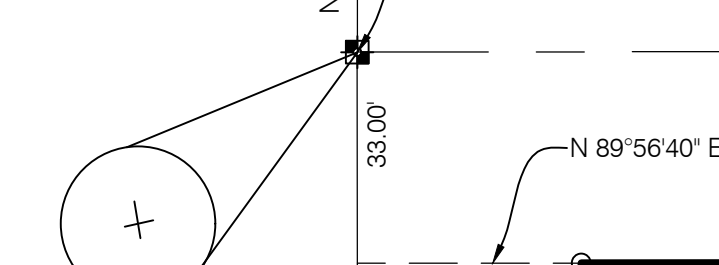
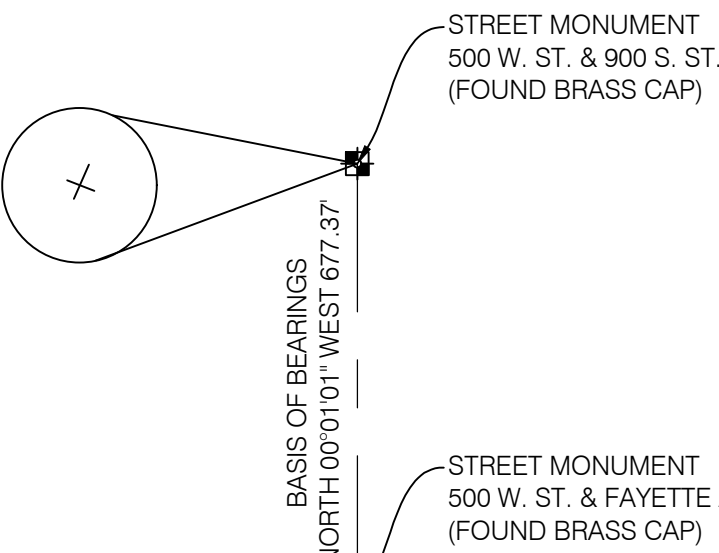

STATEMENT OF ACCURACY, MINIMUM LINEAR CLOSURE OF 1:15,000.

NUMBER _____	 BENCHMARK ENGINEERING & LAND SURVEYING 9138 SOUTH STATE STREET SUITE # 100 SANDY, UTAH 84070 (801) 542-7192 www.benchmarkcivil.com	SALT LAKE COUNTY HEALTH DEPARTMENT APPROVED THIS _____ DAY OF _____ A.D., 20____	CITY PLANNING DIRECTOR APPROVED THIS _____ DAY OF _____ A.D., 20____, BY THE SALT LAKE CITY PLANNING COMMISSION.	CITY PUBLIC UTILITIES DEPT. APPROVED AS TO SEWER AND WATER DETAILS THIS ____ DAY OF _____, A.D., 20____	CITY ENGINEERING DIVISION I HEREBY CERTIFY THAT I HAVE HAD THIS PLAT EXAMINED BY THIS OFFICE AND IT IS CORRECT IN ACCORDANCE WITH INFORMATION ON FILE.	CITY ATTORNEY APPROVED AS TO FORM THIS ____ DAY OF _____, A.D., 20____	CITY APPROVAL PRESENTED TO SALT LAKE CITY THIS _____ DAY OF _____, A.D., 20____ AT WHICH TIME THIS SUBDIVISION WAS APPROVED AND ACCEPTED	SALT LAKE COUNTY RECORDER RECORDED # _____ STATE OF UTAH, COUNTY OF SALT LAKE, RECORDED AND FILED AT THE REQUEST OF _____ DATE _____ TIME _____ BOOK _____ PAGE _____ FEE \$ _____	NUMBER _____	
ACCOUNT _____		STATE OF UTAH, COUNTY OF SALT LAKE, RECORDED AND FILED AT THE REQUEST OF _____	SALT LAKE COUNTY HEALTH DEPARTMENT	PLANNING DIRECTOR _____ DATE _____	SALT LAKE CITY PUBLIC UTILITIES DIRECTOR _____	CITY ENGINEER _____ DATE _____	SALT LAKE CITY ATTORNEY _____	SALT LAKE CITY MAYOR _____ SALT LAKE CITY RECORDER _____	DEPUTY SALT LAKE COUNTY RECORDER _____	ACCOUNT _____
SHEET _____						CITY SURVEYOR _____ DATE _____				SHEET _____
OF ____ SHEETS										OF ____ SHEETS

EXHIBIT

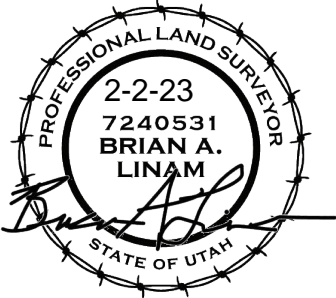

500 WEST STREET
(PUBLIC ROAD)

BROOKLYN AVENUE
(VACATED)

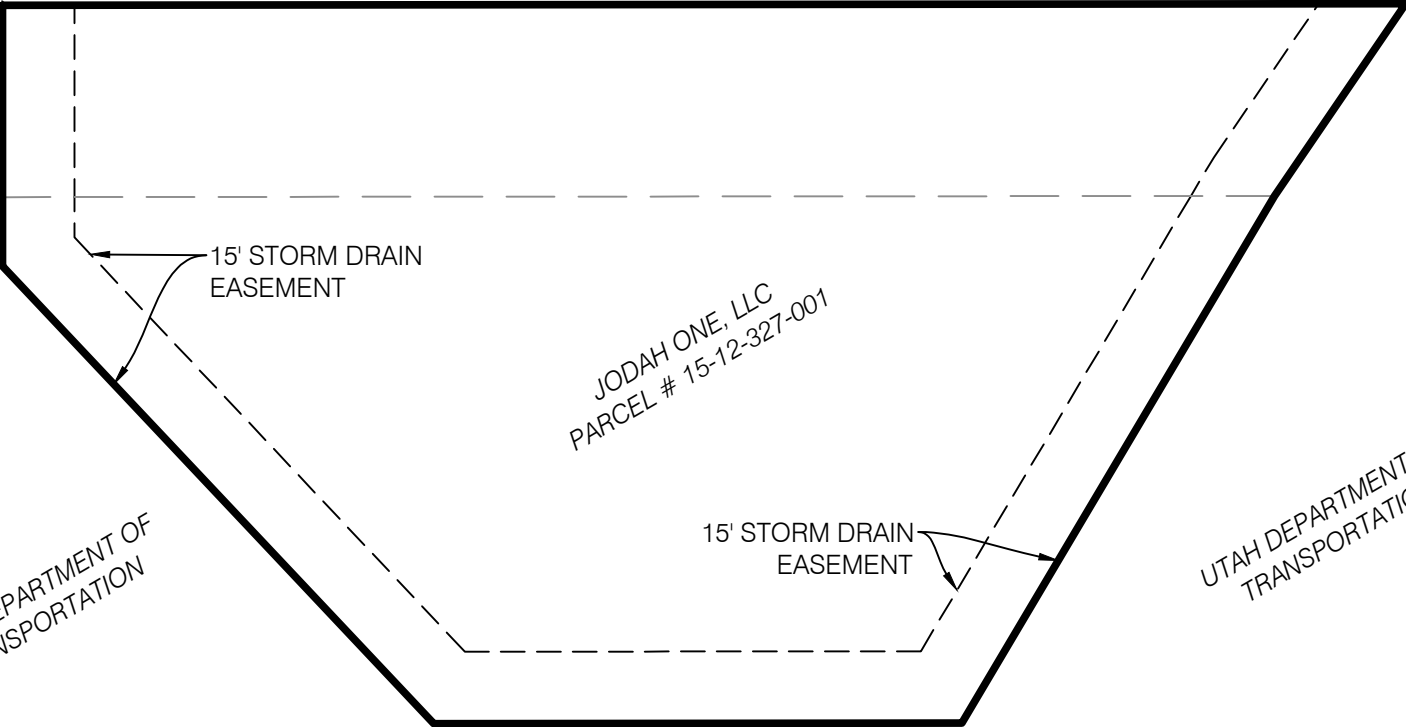

15' STORM DRAIN
EASEMENT

JODAH ONE, LLC
PARCEL # 15-12-327-001

15' STORM DRAIN
EASEMENT

UTAH DEPARTMENT OF
TRANSPORTATION

UTAH DEPARTMENT OF
TRANSPORTATION

SCALE: 1" = 40'
DRAWN: 02.01.2023
CHECKED: 02.01.2023
APPROVED: 02.01.2023

STORM EASEMENT
1007 SOUTH 500 WEST

DWG. NO. 2112349e.dwg
PROJECT. NO. 2112349

EXHIBIT

EXHIBIT



KISSIMAKIS PROPERTIES LLC
PARCEL # 15-12-326-003

KISSIMAKIS PROPERTIES LLC
PARCEL # 15-12-326-004

KISSIMAKIS PROPERTIES LLC
PARCEL # 15-12-326-005

SLC REAL ESTATE INVESTMENTS, LLC
PARCEL # 15-12-326-007

BROOKLYN AVENUE
(VACATED)

15' STORM DRAIN
EASEMENT

UTAH DEPARTMENT OF
TRANSPORTATION

JODAH ONE, LLC
PARCEL # 15-12-327-001

500 WEST STREET
(PUBLIC ROAD)

SCALE: 1" = 50'

DRAWN: 02.01.2023

CHECKED: 02.01.2023

APPROVED: 02.01.2023

STORM EASEMENT
1007 SOUTH 500 WEST

EXHIBIT

DWG. NO. 2112349e.dwg
PROJECT. NO. 2112349

EXHIBIT

FAYETTE AVENUE
(PUBLIC ROAD)



SCALE: 1" = 50'

DRAWN:

02.01.2023

CHECKED:

02.01.2023

APPROVED:

02.01.2023

KISSIMAKIS PROPERTIES LLC
PARCEL # 15-12-326-003

SLC REAL ESTATE INVESTMENTS, LLC
PARCEL # 15-12-326-007

INFINITE INCEPTION INC.
PARCEL # 15-12-326-008

KISSIMAKIS PROPERTIES LLC
PARCEL # 15-12-326-005

15' STORM DRAIN
EASEMENT

UTAH DEPARTMENT OF
TRANSPORTATION

BROOKLYN AVENUE
(VACATED)



STORM EASEMENT
1007 SOUTH 500 WEST

EXHIBIT

DWG. NO. 2112349e.dwg
PROJECT. NO. 2112349

OWNERS AFFIDAVIT

I(we), KESSIMAKIS PROPERTIES am(are) the rightful owner(s) of

property located at 995 S and 1005 S 500 W and 455 W Fayette Ave Salt lake City UT involved in the application to vacate the street of Brooklyn Ave adjacent to our parcel. I acknowledge by my signature below that we are in support of this application. Further, I(we) agree to let the above named agent negotiate on my(our) behalf and I(we) acknowledge my(our) understanding that I(we) will be bound by all conditions specified in any approval of this Planning & Zoning application that is before the City of Salt Lake. The foregoing statements and answers herein contained and the statements and answers contained in the attached plans and exhibits, to the best of my(our) knowledge and belief are true and correct.

Gary Kessimakis (signature of property owner)

Linda Kessimakis (signature of property owner)

Dated this 10 day of June, 2022 State of Utah)
County of Salt Lake)

On the 10 day of June, 2022, personally appeared before me Gary KESSIMAKIS and Linda KESSIMAKIS the signer(s) of the above instrument, who duly subscribed and swore before me that they executed the same.

NOTARY PUBLIC [Signature]
Residing in Salt Lake County, Utah Commission expires: July 05, 2023

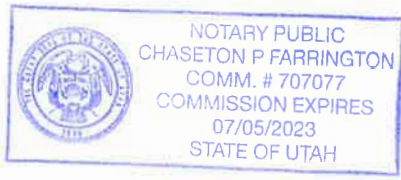

NARI
 SCOPE
 BENCHMARK
 TO PERI
 BASIS O
 THE BAC

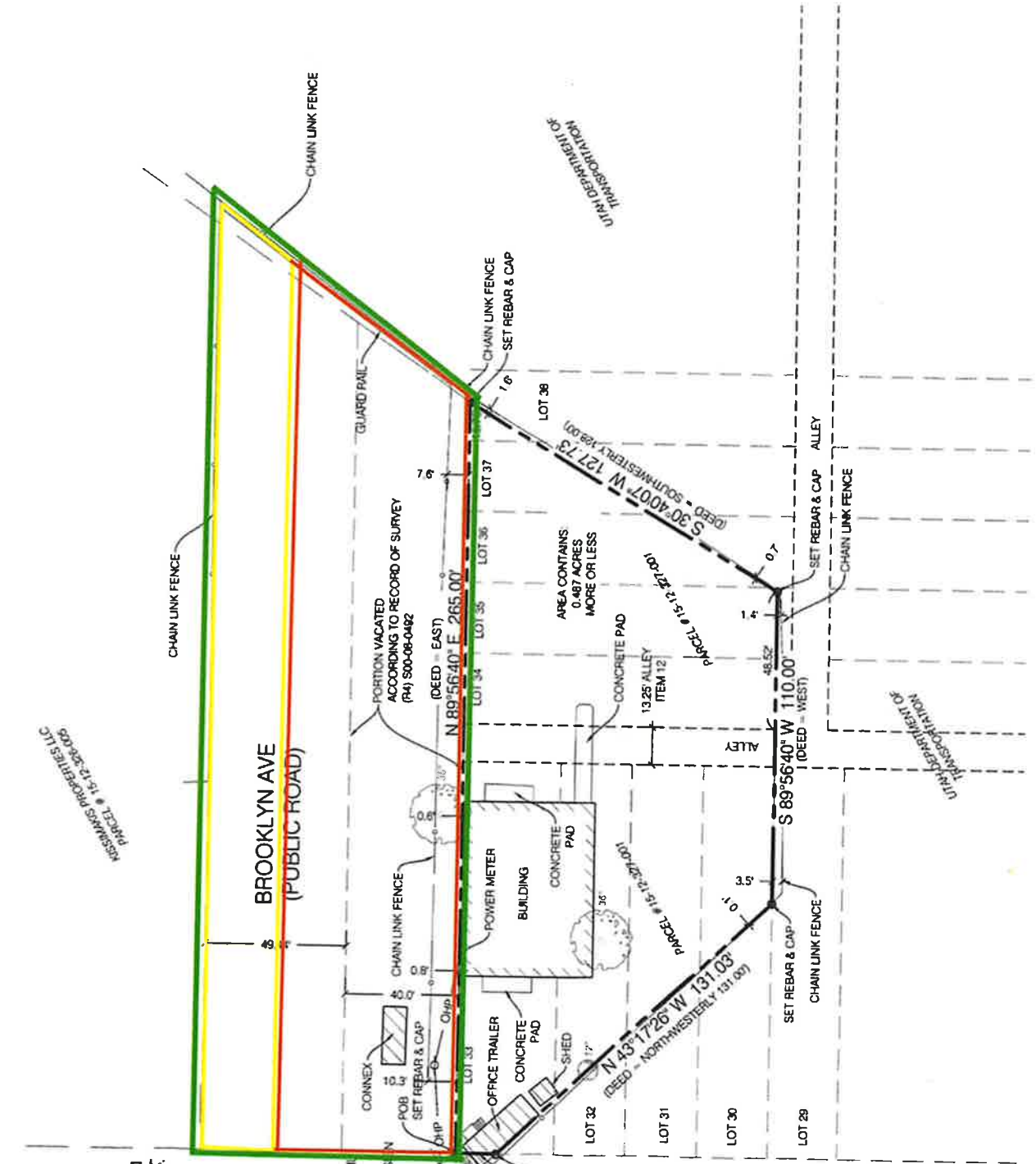

Need Legal for the total area that will be vacated. This includes the 49' road (brooklyn ave) and the 40' wide area that we already have the legal for.

Need Legal for the north 50% of the 49' road (brooklyn ave) This will be given to the northern property owners

Need Legal for the South 50% of the 49' road (brooklyn ave) and the "portion vacated" This will be given to the southern property owners



SALT LAKE CITY PLANNING

Preliminary Subdivision Plat

New Lots

Amendment

OFFICE USE ONLY

Project #:	Received By:	Date Received:	Zoning:
------------	--------------	----------------	---------

Proposed Subdivision Name:

PLEASE PROVIDE THE FOLLOWING INFORMATION

Property Address(s):
1007 S 500 W, SALT LAKE CITY UT

Name of Applicant:
JODAH ONE LLC / JONAH HORNSBY

Address of Applicant:
1075 E HOLLYWOOD AVE, SLC UT 84105

E-mail of Applicant:
JONAH@ACRESUTAH.COM

Applicant's Interest in Subject Property:
 Owner
 Engineer
 Architect
 Other:

Name of Property Owner (if different from applicant):
SAME

Please note that additional information may be required by the project planner to ensure adequate information is provided for staff analysis. All information required for staff analysis will be copied and made public, including professional architectural or engineering drawings, for the purposes of public review by any interested party.

WHERE TO FILE THE COMPLETE APPLICATION

Apply online through the [Citizen Access Portal](#). There is a [step-by-step guide](#) to learn how to submit online.

REQUIRED FEE

Filing fee of \$428 plus \$121 per lot proposed on the plat. Plus, additional fee for required public notices

SIGNATURE

If applicable, a notarized statement of consent authorizing applicant to act as an agent will be required.

Signature of Owner or Agent: 	Date: 5/30/2023
--	--------------------

ACKNOWLEDGEMENT OF RESPONSIBILITY

This is to certify that I am making an application for the described action by the City and that I am responsible for complying with all City requirements with regard to this request. This application will be processed under the name provided below. By signing the application, I am acknowledging that I have read and understood the instructions provided by Salt Lake City for processing this application. The documents and/or information I have submitted are true and correct to the best of my knowledge. I understand that the documents provided are considered public records and may be made available to the public. I understand that my application will not be processed until the application is deemed complete by the assigned planner from the Planning Division. I acknowledge that a complete application includes all of the required submittal requirements and provided documents comply with all applicable requirements for the specific applications. I understand that the Planning Division will provide, in writing, a list of deficiencies that must be satisfied for this application to be complete and it is the responsibility of the applicant to provide the missing or corrected information. I will keep myself informed of the deadlines for submission of material and the progress of this application. I understand that a staff report will be made available for my review prior to any public hearings or public meetings. This report will be on file and available at the Planning Division and posted on the Division website when it has been finalized.

APPLICANT SIGNATURE

Name of Applicant: <u>JODAH ONE, LLC / JUNAH HORNBY</u>	Application Type: <u>PRELIMINARY PLAT</u>
Mailing Address: <u>1075 E HOLLYWOOD AVE SALT LAKE CITY UT 84105</u>	
Email: <u>JUNAH@ACRESUTAH.COM</u>	Phone: <u>801-580-4945</u>
Signature: 	Date: <u>5/30/2023</u>

AFFIRMATION OF SUFFICIENT INTEREST

I hereby affirm that I am the fee title owner of the below described property or that I have written authorization from the owner to pursue the described action.

FEE TITLE OWNER SIGNATURE

Legal Description of Subject Property: <u>SEE ATTACHED SURVEY</u>	
Name of Owner: <u>JODAH ONE, LLC</u>	
Mailing Address: <u>1075 E HOLLYWOOD AVE SLC UT</u>	Street Address: <u>1007 S 500 W SLC UT</u>
Signature: 	Date:

The following shall be provided if the name of the applicant is different than the name of the property owner:

1. If you are not the fee owner attach a copy of your authorization to pursue this action provided by the fee owner.
2. If a corporation is fee titleholder, attach copy of the resolution of the Board of Directors authorizing the action.
3. If a joint venture or partnership is the fee owner, attach a copy of agreement authorizing this action on behalf of the joint venture or partnership
4. If a Home Owner's Association is the applicant than the representative/president must attach a notarized letter stating they have notified the owners of the proposed application. A vote should be taken prior to the submittal and a statement of the outcome provided to the City along with the statement that the vote meets the requirements set forth in the CC&Rs.

Be advised that knowingly making a false, written statement to a government entity is a crime under Utah Code Chapter 76-8, Part 5. Salt Lake City will refer for prosecution any knowingly false representations made pertaining to the applicant's interest in the property that is the subject of this application.

SUBMITTAL REQUIREMENTS

Staff Review

Please include with the application (*please attach electronically additional sheet/s if necessary*):



Project Description

A written description of what is being proposed.



Preliminary Plat Drawing

A digital (PDF) copy of the preliminary plat drawing. See plat content requirements on the following page.



Legal Descriptions (OPTIONAL)

Legal descriptions should be provided with the application if the subdivision meets all of the following conditions: (1) it contains 10 or less lots, (2) does not amend an existing subdivision plat, (3) does not require public right of way improvements, and (4) the applicant *prefers* to finalize the subdivision with deeds rather than a final plat. If applicable, please include the following:

- A digital file (ex: Word or PDF) of the legal description of the current boundaries of the subject property and the legal descriptions of each of the proposed lots.

APPEAL PROCESS

- ➔ Any person adversely and materially affected by any final decision made by the planning director or designee may file a petition for review of the decision with the planning commission within ten (10) days after the record of decision is posted to the city's internet site.
- ➔ Any person adversely affected by any final decision made by the planning commission under this chapter may file a petition for review of the decision with the Appeals Hearing Officer within ten (10) days after the decision is rendered.

AVAILABLE CONSULTATION

- ➔ Planners are available for consultation prior to submitting this application. Please email zoning@slcgov.com if you have any questions regarding the requirements of this application.

INCOMPLETE APPLICATIONS WILL NOT BE ACCEPTED

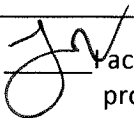

I acknowledge that Salt Lake City requires the items above to be submitted before my application can be processed. I understand that Planning will not accept my application unless all of the following items are included in the submittal package.

THE FOLLOWING INFORMATION SHALL BE SHOWN ON THE PRELIMINARY PLAT OR IN AN ACCOMPANYING DATA STATEMENT:

1. Any subdivision that includes recordation of a final plat shall be given a name. Such subdivision names shall not duplicate or nearly duplicate the name of any subdivision in the city or county;
2. The name and address of the record owner or owners;
3. The name and address of the subdivider; if different from the recorded owner, there shall be a statement from the recorded owner authorizing the subdivider to act;
4. The name, address and phone number of the person, firm or organization preparing the preliminary plat, and a statement indicating the recorded owner's permission to file the plat;
5. The date, north direction, written and graphic scales;
6. A sufficient description to define the location and boundaries of the proposed subdivision;
7. Vicinity map showing general location of the project at a scale of 1" = 1,000' or similar.
8. The locations, names and existing widths and grades of adjacent streets;
9. The names and numbers of adjacent subdivisions and the names of owners of adjacent unplatted land;
10. The contours, at one foot (1') intervals, for predominant ground slopes within the subdivision between level and five percent (5%), and five foot (5') contours for predominant ground slopes within the subdivisions over five percent (5%). Such contours shall be based on the Salt Lake City datum. The closest city bench mark shall be used, and its elevation called out on the map. Bench mark information shall be obtained from the city engineer;
11. A grading plan, showing by appropriate graphic means the proposed grading of the subdivision;
12. The approximate location of all isolated trees with a trunk diameter of four inches (4") or greater, within the boundaries of the subdivision, and the outlines of groves or orchards;
13. The approximate boundaries of areas subject to inundation or storm water overflow, and the location, width and direction of flow of all watercourses;
14. The existing use or uses of the property, and the outline of any existing buildings and their locations in relation to existing or proposed street and lot lines, drawn to scale;
15. A statement of the present zoning and proposed use of the property, as well as proposed zoning changes, whether immediate or future;
16. Any proposed public areas;
17. Any proposed lands to be retained in private ownership for community use. When a subdivision contains such lands, the subdivider shall submit, with the preliminary plat, the name and articles of incorporation of the owner or organization empowered to own, maintain and pay taxes on such lands;
18. The approximate widths, locations and uses of all existing or proposed easements for drainage, sewerage and public utilities;
19. The approximate radius of each curve;
20. The approximate layout and dimensions of each lot;
21. The area of each lot to the nearest one hundred (100) square feet;
22. A statement of the water source;
23. A statement of provisions for sewerage and sewage disposal;
24. Preliminary indication of needed major storm drain facilities;
25. The locations, names, widths, approximate grades and a typical cross section of curbs, gutters, sidewalks and other improvements of the proposed street and access easements, including proposed locations of all underground utilities;
26. Any existing or proposed dedications, easements and deed restrictions;
27. A preliminary landscaping plan, including, where appropriate, measures for irrigation and maintenance;
28. The location of any of the foregoing improvements which may be required to be constructed beyond the boundaries of the subdivision shall be shown on the subdivision plat or on the vicinity map as appropriate;
29. If it is contemplated that the development will proceed by units, the boundaries of such units shall be shown on the preliminary plat;
30. If required by the planning director, a preliminary soil report prepared by a civil engineer specializing in soil mechanics and registered by the state of Utah, based upon adequate test borings or excavations. If the preliminary soil report indicates the presence of critically expansive soils or other soil problems which, if not corrected, would lead to structural defects, a soil investigation of each lot in the subdivision may be required. The soil investigation shall recommend corrective action intended to prevent structural damage.



Preliminary Subdivision Plat

New Lots

Amendment

OFFICE USE ONLY

Project #:	Received By:	Date Received:	Zoning:
------------	--------------	----------------	---------

Proposed Subdivision Name:

PLEASE PROVIDE THE FOLLOWING INFORMATION

Property Address(s):
1005 S 500 W, SALT LAKE CITY, UT

Name of Applicant: JONAH HORNSBY / JODY JONES Phone: 801-580-4945

Address of Applicant: 1075 E HOLLYWOOD AVE SLC UT 84105

E-mail of Applicant: JONAH@KACRESUTAH.COM Cell/Fax: 801-580-4945

Applicant's Interest in Subject Property:

Owner Engineer Architect Other: AGENT

Name of Property Owner (if different from applicant):
KESSIMAKIS PROPERTIES, LLC

E-mail of Property Owner: Phone:

Please note that additional information may be required by the project planner to ensure adequate information is provided for staff analysis. All information required for staff analysis will be copied and made public, including professional architectural or engineering drawings, for the purposes of public review by any interested party.

WHERE TO FILE THE COMPLETE APPLICATION

Apply online through the [Citizen Access Portal](#). There is a [step-by-step guide](#) to learn how to submit online.

REQUIRED FEE

Filing fee of \$428 plus \$121 per lot proposed on the plat. Plus, additional fee for required public notices

SIGNATURE

If applicable, a notarized statement of consent authorizing applicant to act as an agent will be required.

Signature of Owner or Agent: 	Date: 5/30/2023
--	--------------------

SALT LAKE CITY PLANNING

ACKNOWLEDGEMENT OF RESPONSIBILITY

This is to certify that I am making an application for the described action by the City and that I am responsible for complying with all City requirements with regard to this request. This application will be processed under the name provided below. By signing the application, I am acknowledging that I have read and understood the instructions provided by Salt Lake City for processing this application. The documents and/or information I have submitted are true and correct to the best of my knowledge. I understand that the documents provided are considered public records and may be made available to the public. I understand that my application will not be processed until the application is deemed complete by the assigned planner from the Planning Division. I acknowledge that a complete application includes all of the required submittal requirements and provided documents comply with all applicable requirements for the specific applications. I understand that the Planning Division will provide, in writing, a list of deficiencies that must be satisfied for this application to be complete and it is the responsibility of the applicant to provide the missing or corrected information. I will keep myself informed of the deadlines for submission of material and the progress of this application. I understand that a staff report will be made available for my review prior to any public hearings or public meetings. This report will be on file and available at the Planning Division and posted on the Division website when it has been finalized.

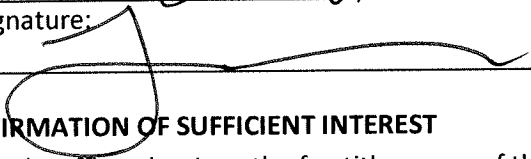
APPLICANT SIGNATURE	
Name of Applicant: JONAH HORNSBY	Application Type: PRELIMINARY PLAT
Mailing Address: 1075 E HOLLYWOOD AVE SALT LAKE CITY, UT 84105	
Email: JONAH@ACRESUTAH.COM	Phone: 801-580-4945
Signature: 	Date: 5/30/2023

AFFIRMATION OF SUFFICIENT INTEREST

I hereby affirm that I am the fee title owner of the below described property or that I have written authorization from the owner to pursue the described action.

FEE TITLE OWNER SIGNATURE	
Legal Description of Subject Property: SEE ATTACHED SURVEY	
Name of Owner: KESSIMAKS PROPERTIES, LLC	
Mailing Address	Street Address: 1005 S 500 W, SALT LAKE CITY UT
Signature:	Date: 05/30/2025

The following shall be provided if the name of the applicant is different than the name of the property owner:

1. If you are not the fee owner attach a copy of your authorization to pursue this action provided by the fee owner.
2. If a corporation is fee titleholder, attach copy of the resolution of the Board of Directors authorizing the action.
3. If a joint venture or partnership is the fee owner, attach a copy of agreement authorizing this action on behalf of the joint venture or partnership
4. If a Home Owner's Association is the applicant than the representative/president must attach a notarized letter stating they have notified the owners of the proposed application. A vote should be taken prior to the submittal and a statement of the outcome provided to the City along with the statement that the vote meets the requirements set forth in the CC&Rs.

Be advised that knowingly making a false, written statement to a government entity is a crime under Utah Code Chapter 76-8, Part 5. Salt Lake City will refer for prosecution any knowingly false representations made pertaining to the applicant's interest in the property that is the subject of this application.

SUBMITTAL REQUIREMENTS

Staff Review

Please include with the application (*please attach electronically additional sheet/s if necessary*):

Project Description

A written description of what is being proposed.

Preliminary Plat Drawing

A digital (PDF) copy of the preliminary plat drawing. See plat content requirements on the following page.

Legal Descriptions (OPTIONAL)

Legal descriptions should be provided with the application if the subdivision meets all of the following conditions: (1) it contains 10 or less lots, (2) does not amend an existing subdivision plat, (3) does not require public right of way improvements, and (4) the applicant *prefers* to finalize the subdivision with deeds rather than a final plat. If applicable, please include the following:

- A digital file (ex: Word or PDF) of the legal description of the current boundaries of the subject property and the legal descriptions of each of the proposed lots.

APPEAL PROCESS

- ➔ Any person adversely and materially affected by any final decision made by the planning director or designee may file a petition for review of the decision with the planning commission within ten (10) days after the record of decision is posted to the city's internet site.
- ➔ Any person adversely affected by any final decision made by the planning commission under this chapter may file a petition for review of the decision with the Appeals Hearing Officer within ten (10) days after the decision is rendered.

AVAILABLE CONSULTATION

- ➔ Planners are available for consultation prior to submitting this application. Please email zoning@slcgov.com if you have any questions regarding the requirements of this application.

INCOMPLETE APPLICATIONS WILL NOT BE ACCEPTED

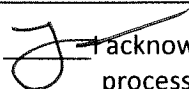
 I acknowledge that Salt Lake City requires the items above to be submitted before my application can be processed. I understand that Planning will not accept my application unless all of the following items are included in the submittal package.

THE FOLLOWING INFORMATION SHALL BE SHOWN ON THE PRELIMINARY PLAT OR IN AN ACCOMPANYING DATA STATEMENT:

1. Any subdivision that includes recordation of a final plat shall be given a name. Such subdivision names shall not duplicate or nearly duplicate the name of any subdivision in the city or county;
2. The name and address of the record owner or owners;
3. The name and address of the subdivider; if different from the recorded owner, there shall be a statement from the recorded owner authorizing the subdivider to act;
4. The name, address and phone number of the person, firm or organization preparing the preliminary plat, and a statement indicating the recorded owner's permission to file the plat;
5. The date, north direction, written and graphic scales;
6. A sufficient description to define the location and boundaries of the proposed subdivision;
7. Vicinity map showing general location of the project at a scale of 1" = 1,000' or similar.
8. The locations, names and existing widths and grades of adjacent streets;
9. The names and numbers of adjacent subdivisions and the names of owners of adjacent unplatted land;
10. The contours, at one foot (1') intervals, for predominant ground slopes within the subdivision between level and five percent (5%), and five foot (5') contours for predominant ground slopes within the subdivisions over five percent (5%). Such contours shall be based on the Salt Lake City datum. The closest city bench mark shall be used, and its elevation called out on the map. Bench mark information shall be obtained from the city engineer;
11. A grading plan, showing by appropriate graphic means the proposed grading of the subdivision;
12. The approximate location of all isolated trees with a trunk diameter of four inches (4") or greater, within the boundaries of the subdivision, and the outlines of groves or orchards;
13. The approximate boundaries of areas subject to inundation or storm water overflow, and the location, width and direction of flow of all watercourses;
14. The existing use or uses of the property, and the outline of any existing buildings and their locations in relation to existing or proposed street and lot lines, drawn to scale;
15. A statement of the present zoning and proposed use of the property, as well as proposed zoning changes, whether immediate or future;
16. Any proposed public areas;
17. Any proposed lands to be retained in private ownership for community use. When a subdivision contains such lands, the subdivider shall submit, with the preliminary plat, the name and articles of incorporation of the owner or organization empowered to own, maintain and pay taxes on such lands;
18. The approximate widths, locations and uses of all existing or proposed easements for drainage, sewerage and public utilities;
19. The approximate radius of each curve;
20. The approximate layout and dimensions of each lot;
21. The area of each lot to the nearest one hundred (100) square feet;
22. A statement of the water source;
23. A statement of provisions for sewerage and sewage disposal;
24. Preliminary indication of needed major storm drain facilities;
25. The locations, names, widths, approximate grades and a typical cross section of curbs, gutters, sidewalks and other improvements of the proposed street and access easements, including proposed locations of all underground utilities;
26. Any existing or proposed dedications, easements and deed restrictions;
27. A preliminary landscaping plan, including, where appropriate, measures for irrigation and maintenance;
28. The location of any of the foregoing improvements which may be required to be constructed beyond the boundaries of the subdivision shall be shown on the subdivision plat or on the vicinity map as appropriate;
29. If it is contemplated that the development will proceed by units, the boundaries of such units shall be shown on the preliminary plat;
30. If required by the planning director, a preliminary soil report prepared by a civil engineer specializing in soil mechanics and registered by the state of Utah, based upon adequate test borings or excavations. If the preliminary soil report indicates the presence of critically expansive soils or other soil problems which, if not corrected, would lead to structural defects, a soil investigation of each lot in the subdivision may be required. The soil investigation shall recommend corrective action intended to prevent structural damage.



Street Closure

SALT LAKE CITY PLANNING

OFFICE USE ONLY

Received By:

Date Received:

Project #:

Project Name:

PLEASE PROVIDE THE FOLLOWING INFORMATION

Name/Location of the Street:

1007 S 500 W, Salt Lake City UT

Name of Applicant:

Jonah Hornsby

Phone:

801-580-4945

Address of Applicant:

1075 E Hollywood Ave, Salt Lake City UT

E-mail of Applicant:

Jonah@acresutah.com

Cell/Fax:

801-580-4945

Applicant's Interest in Subject Property:

Owner Contractor Architect Other:

Name of Property Owner abutting the street (if different from applicant):

N/A

E-mail of Property Owner:

Jonah@acresutah.com

Phone:

801-580-4945

Please note that additional information may be required by the project planner to ensure adequate information is provided for staff analysis. All information required for staff analysis will be copied and made public, including professional architectural or engineering drawings, for the purposes of public review by any interested party.

AVAILABLE CONSULTATION

Planners are available for consultation prior to submitting this application. Please email zoning@slcgov.com if you have any questions regarding the requirements of this application.

WHERE TO FILE THE COMPLETE APPLICATION

Apply online through the [Citizen Access Portal](#). There is a [step-by-step guide](#) to learn how to submit online.

REQUIRED FEE

Filing fee of **\$403**

Plus, additional fee for required public notices. Noticing fees will be assessed after application is submitted.

SIGNATURE

➔ If applicable, a notarized statement of consent authorizing applicant to act as an agent will be required.

Signature of Owner or Agent:

Date:

1/18/2022

SUBMITTAL REQUIREMENTS

Staff Review

Please include with the application: (please electronically attach additional sheets)

- | | | |
|--------------------------|-------------------------------------|---|
| <input type="checkbox"/> | <input checked="" type="checkbox"/> | 1. A letter explaining why you are requesting this Street Closure. |
| <input type="checkbox"/> | <input checked="" type="checkbox"/> | 2. A Sidwell map showing the area of the proposed Street Closure. On the map please: |
| <input type="checkbox"/> | <input checked="" type="checkbox"/> | a. Highlight the area of the proposed Street Closure. |
| <input type="checkbox"/> | <input checked="" type="checkbox"/> | b. Indicate the property owners abutting the proposed Street Closure. |
| <input type="checkbox"/> | <input checked="" type="checkbox"/> | c. Submit a digital (PDF) copy of the map. |
| <input type="checkbox"/> | <input checked="" type="checkbox"/> | 3. A written description with the width and length measurements of the proposed Street Closure. |
| | | • A final legal description prepared by a licensed engineer will be required later. |
| <input type="checkbox"/> | <input checked="" type="checkbox"/> | 4. The name, address and signatures of all abutting property owners who support the petition. |
| | | • You may use the form attached to this application or provide your own form with signatures. |
| | | • Signatures should be from the property owners and not from the property renters. |

➔ Please be aware that once the City closes the street it will then sell the property at fair market value to the abutting property owners.

INCOMPLETE APPLICATIONS WILL NOT BE ACCEPTED

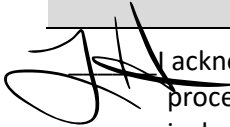
 I acknowledge that Salt Lake City requires the items above to be submitted before my application can be processed. I understand that Planning will not accept my application unless all of the following items are included in the submittal package.

PETITION TO CLOSE A STREET

Name of Applicant:
Jonah Hornsby

Address of Applicant:
1075 E Hollywood Ave, Salt Lake City UT

Date:
1/18/2022

As an owner of property adjacent to the street, I agree to the proposed street closure. I also understand that I have the option to purchase the portion of the street adjacent to my property at fair market value.

<i>Print Name</i>	<i>Address</i>	<i>Signature</i>	<i>Date</i>
-------------------	----------------	------------------	-------------

<i>Print Name</i>	<i>Address</i>	<i>Signature</i>	<i>Date</i>
-------------------	----------------	------------------	-------------

<i>Print Name</i>	<i>Address</i>	<i>Signature</i>	<i>Date</i>
-------------------	----------------	------------------	-------------

<i>Print Name</i>	<i>Address</i>	<i>Signature</i>	<i>Date</i>
-------------------	----------------	------------------	-------------

<i>Print Name</i>	<i>Address</i>	<i>Signature</i>	<i>Date</i>
-------------------	----------------	------------------	-------------

<i>Print Name</i>	<i>Address</i>	<i>Signature</i>	<i>Date</i>
-------------------	----------------	------------------	-------------

<i>Print Name</i>	<i>Address</i>	<i>Signature</i>	<i>Date</i>
-------------------	----------------	------------------	-------------

<i>Print Name</i>	<i>Address</i>	<i>Signature</i>	<i>Date</i>
-------------------	----------------	------------------	-------------

<i>Print Name</i>	<i>Address</i>	<i>Signature</i>	<i>Date</i>
-------------------	----------------	------------------	-------------

<i>Print Name</i>	<i>Address</i>	<i>Signature</i>	<i>Date</i>
-------------------	----------------	------------------	-------------

<i>Print Name</i>	<i>Address</i>	<i>Signature</i>	<i>Date</i>
-------------------	----------------	------------------	-------------

<i>Print Name</i>	<i>Address</i>	<i>Signature</i>	<i>Date</i>
-------------------	----------------	------------------	-------------

<i>Print Name</i>	<i>Address</i>	<i>Signature</i>	<i>Date</i>
-------------------	----------------	------------------	-------------



Alley Vacation or Closure

SALT LAKE CITY PLANNING

OFFICE USE ONLY

Received By:	Date Received:	Project #:
--------------	----------------	------------

Project Name:

PLEASE PROVIDE THE FOLLOWING INFORMATION

Location of the Alley:
1007 S 500 W Salt Lake City, UT

Name of Applicant: Jonah Hornsby	Phone: 801-580-4945
-------------------------------------	------------------------

Address of Applicant:
1075 E Hollywood Ave, Salt Lake City UT 84105

E-mail of Applicant: Jonah@acresutah.com	Cell/Fax: 801-580-4945
---	---------------------------

Applicant's Interest in Subject Property:

Owner Contractor Architect Other:

Name of Property Owner abutting the alley (if different from applicant):
N/A Alley only abutts the subject property

E-mail of Property Owner: jonah@acresutah.com	Phone: 801-580-4945
--	------------------------

Please note that additional information may be required by the project planner to ensure adequate information is provided for staff analysis. All information required for staff analysis will be copied and made public, including professional architectural or engineering drawings, for the purposes of public review by any interested party.

AVAILABLE CONSULTATION

Planners are available for consultation prior to submitting this application. Please email zoning@slcgov.com if you have any questions regarding the requirements of this application.

WHERE TO FILE THE COMPLETE APPLICATION

Apply online through the [Citizen Access Portal](#). There is a [step-by-step guide](#) to learn how to submit online.

REQUIRED FEE

Filing fee of **\$269**
Plus additional fee for required public notices will be assessed after application is submitted.

SIGNATURE

➔ If applicable, a notarized statement of consent authorizing applicant to act as an agent will be required.

Signature of Owner or Agent: 	Date: 3/7/2022
---	-------------------

SUBMITTAL REQUIREMENTS

Staff Review

<input type="checkbox"/>	<input checked="" type="checkbox"/>
<input type="checkbox"/>	<input checked="" type="checkbox"/>
<input type="checkbox"/>	<input checked="" type="checkbox"/>
<input type="checkbox"/>	<input checked="" type="checkbox"/>
<input type="checkbox"/>	<input checked="" type="checkbox"/>
<input type="checkbox"/>	<input checked="" type="checkbox"/>
<input type="checkbox"/>	<input checked="" type="checkbox"/>

Please include with the application: (please attach additional sheets electronically)

1. A letter explaining why you are requesting this alley vacation or closure.
2. A Sidwell map showing the area of the proposed alley vacation or closure. On the map please:
 - a. Highlight the area of the proposed alley vacation or closure.
 - b. Indicate with colored dot the property owners who support the petition.
 - c. Submit a digital (PDF) copy of the map.
3. A written description with measurements of the proposed alley vacation or closure.
 - A final legal description prepared by a licensed engineer will be required later.
4. The name, address and signatures of all abutting property owners who support the petition.
 - Petition must include the signatures of no less than 80% of the abutting property owners.
 - Signatures should be from the property owners and not from the property renters.
 - You may use the form attached to this application or provide your own form with signatures.

WHAT IS AN ALLEY VACATION OR CLOSURE?

As part of the subdivision process, early developers were required to create alleys which were then deeded to the City. They were used for coal delivery, garbage pickup and other services. They also allowed access to garages. Today, the City is officially the owner of these alleys. In situations where it can be demonstrated that there is an over-riding public purpose for vacating the alley, the City may relinquish its property interest in the alley.

When an alley is next to or abuts a single family or duplex residential property, the City **vacates** the alley, divides it in half, and the property is conveyed to the abutting property owners. If an alley is next to or abuts a non-residential, or multifamily residential (3 or more dwelling units) property, the City may **close** the alley and then **sell** the land at fair market value to the abutting property owners.

WHAT THE CITY CONSIDERS BEFORE VACATING OR CLOSING AN ALLEY [Section 14.52.020](#)

1. The City police department, fire department, transportation division, and all other relevant City departments have no reasonable objection to the proposed disposition of the property;
2. Granting the petition will not deny sole access or required off-street parking to any property adjacent to the alley;
3. Granting the petition will not result in any property being landlocked;
4. Granting the petition will not result in a use of the alley property which is otherwise contrary to the policies of the City, including applicable master plans and other adopted statements of policy which address, but which are not limited to, mid-block walkways, pedestrian paths, trails, and alternative transportation uses;
5. No opposing abutting property owner intends to build a garage requiring access from the property, or has made application for a building permit, or if such a permit has been issued, construction has been completed within 12 months of issuance of the building permit;
6. The petition furthers the City preference for disposing of an entire alley, rather than a small segment of it; and
7. The alley property is not necessary for actual or potential rear access to residences or for accessory uses.

INCOMPLETE APPLICATIONS WILL NOT BE ACCEPTED

 I acknowledge that Salt Lake City requires the items above to be submitted before my application can be processed. I understand that Planning will not accept my application unless all of the following items are included in the submittal package.

PETITION TO VACATE OR CLOSE AN ALLEY

Name of Applicant:
Jonah Hornsby

Address of Applicant:
1075 E Hollywood Ave Salt Lake City, UT

Date:
3/7/2022

As an owner of property adjacent to the alley, I agree to the proposed vacation or closure. I understand that if my property is a commercial business or a rental property with more than three (3) dwelling units, I will be required to pay fair market value for my half of the alley.

Print Name Address Signature Date

Print Name Address Signature Date

Print Name Address Signature Date

Print Name Address Signature Date

Print Name Address Signature Date

Print Name Address Signature Date

Print Name Address Signature Date

Print Name Address Signature Date

Print Name Address Signature Date

Print Name Address Signature Date

Print Name Address Signature Date

Print Name Address Signature Date

Print Name Address Signature Date

ATTACHMENT C: Property & Vicinity Photos



1007 South 500 West, facing southwest



1007 South 500 West, facing southeast



South wall of 1005 West 500 South



Business located at 1007 West 500 South (addressed at 995 South)



Clockwise from top left:

- *Corner of Brooklyn Avenue and 500 W, facing west*
- *East side of 500 W, facing north*
- *Corner of Brooklyn Avenue and 500 W, facing southwest*
- *West side of 500 W, facing north*
- *500 W, facing north from Brooklyn Avenue*

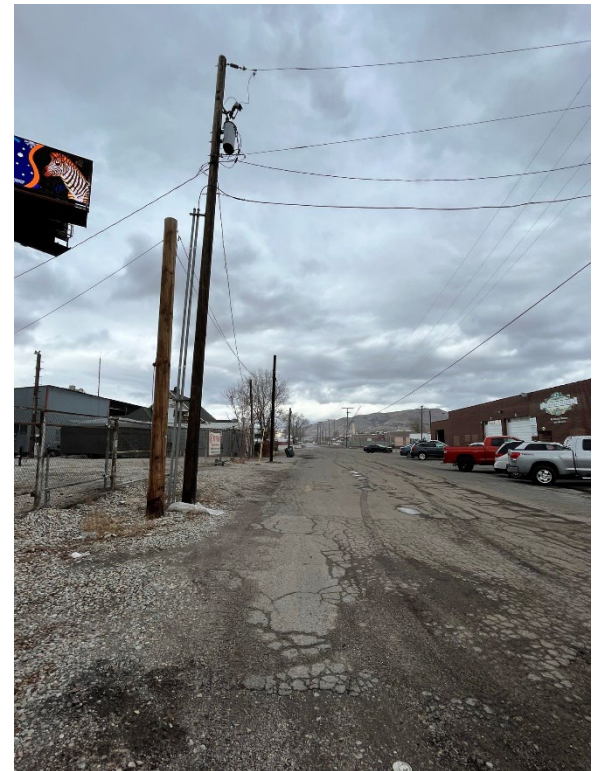



- Clockwise from top left:*
- *500 W and Fayette Ave, facing west*
 - *500 W and Fayette Ave, facing northwest*
 - *500 W, facing south*



Clockwise from top left:

- *Fayette Avenue, facing east from 500 W*
- *Fayette Avenue facing west*
- *Fayette Avenue facing west from property to the east*
- *Fayette Avenue facing east*
- *500 W and Fayette Ave, facing south*
- *500 W, facing south*





East boundary of Brooklyn Avenue, at West Temple Viaduct



East boundary of Brooklyn Avenue, at West Temple Viaduct, facing south



East boundary of Brooklyn Avenue, facing north



Brooklyn Avenue, facing west from east boundary

ATTACHMENT D: Historical Aerial Photos

The following aerial photographs were obtained from the Utah Geological Survey (UGS) *Aerial Imagery Database*.



1937

1958





1964

1985

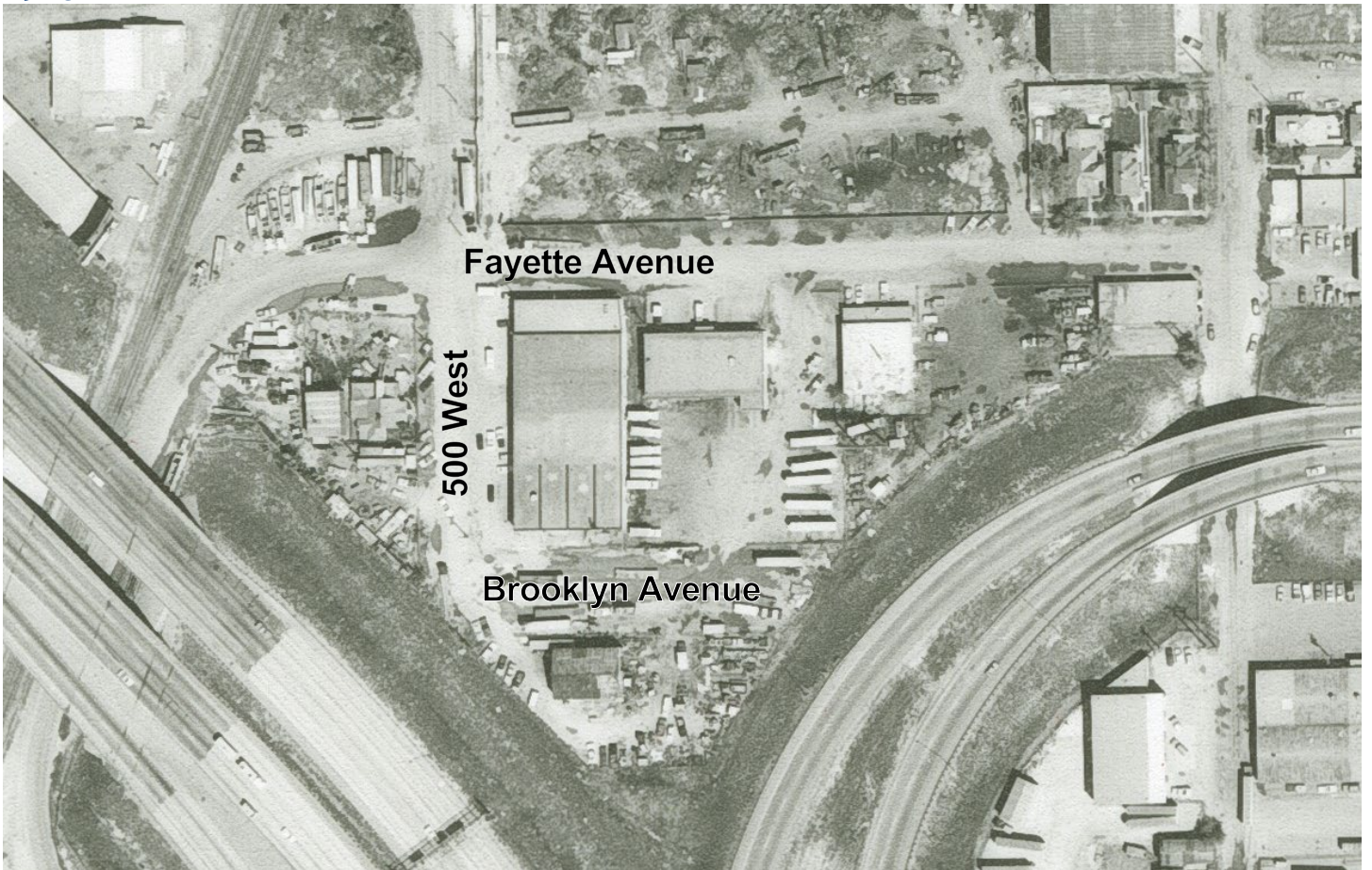



1999

ATTACHMENT E: Development Standards Review

Zoning Standards

The intent of the following zoning standards review is to analyze how the proposed vacations and Subdivision Amendment would affect the adjoining properties' compliance with applicable lot and bulk regulations.

CG General Commercial Purpose Statement (21A.26.070.A)

The purpose of the CG General Commercial District is to provide an environment for a variety of commercial uses, some of which involve the outdoor display/storage of merchandise or materials. This district provides economic development opportunities through a mix of land uses, including retail sales and services, entertainment, office, residential, heavy commercial and low intensities of manufacturing and warehouse uses. This district is appropriate in locations where supported by applicable master plans and along major arterials. Safe, convenient and inviting connections that provide access to businesses from public sidewalks, bike paths and streets are necessary. Access should follow a hierarchy that places the pedestrian first, bicycle second and automobile third. The standards are intended to create a safe and aesthetically pleasing commercial environment for all users.

Applicable Zoning Standards

Standard	South Property	North Property	Finding
Minimum Lot Area: 10,000 sq. ft.	Before: 21,344 sq ft After: 33,767 sq ft	Before: 37,462 sq ft After: 91,545 sq ft	Complies
Minimum Lot Width: 60 ft	Before: 15 ft (Facing 500 W, as addressed) After: 55 ft	Before: 77 ft (Facing 500 W) After: 333 ft (Facing Fayette Ave)	Complies with conditions
Minimum Front Yard Setback: 5 ft Maximum Front Yard Setback: 10 ft	Before: 55 ft After: 55 ft (Facing 500 W, as addressed)	Before: 25 ft (Facing 500 W) After: 5 ft (Facing Fayette Ave)	Complies
Min. Corner Side Yard Setback: 10 ft	Before: 0 ft (Adjacent to Brooklyn Ave) After: None	Before: 18 ft (Adjacent to Brooklyn Ave) After: 25 ft (Adjacent to 500 W)	Complies
Min. Interior Side Yard Setback: none	Before: 18 ft After: 12 ft	Before: 0 ft (North property line) After: 70 ft (East property line)	Complies
Min. Rear Yard Setback: 10 ft	Before: 18 ft After: 12 ft	Before: 190 ft (East property line) After: 18 ft (South property line)	Complies

Subdivision Design Standards

20.12 Subdivision Design Standards Checklist

Standard	Staff Review	Compliance
20.12.010 General Regulations and Standards: Except where modified by the planning commission or its designee, all subdivision of land within Salt Lake City shall comply and conform with the design standards and requirements as set forth and as referred to in this section, as follows:		
A. Supervision: All subdivision development work performed under this section will be allowed only when said work is performed under the supervision of the city engineer, transportation director and/or public utilities director in accordance with the approved subdivision plan, and said work is secured by a performance guarantee bond or other security device acceptable to the city attorney and mayor.	The proposed preliminary plat has been completed and stamped by a licensed engineer.	Finding: Complies
B. Preservation Of Natural Features: Trees, native ground cover, natural watercourses, and topography shall be preserved when possible, and the subdivision shall be so designed as to prevent excessive grading and scarring of the landscape in conformance with this title.	No site improvements are proposed with this subdivision amendment.	Finding: Complies
C. Hazardous Areas To Be Fenced: All areas of the subdivision or features adjacent to the subdivision, which present a potential threat to the public safety shall be fenced with a six foot (6') non-climbable fence or acceptable alternative, as required by the planning commission or its designee. Such hazardous areas may include, but are not limited to, rivers and streams, canals, cliffs, ravines, railroad rights of way, and steep slopes. Required fencing shall be constructed and included as part of the subdivision improvements and shall be bonded.	No hazardous areas have been identified on the site.	Finding: Not Applicable
D. Buildable Lots: All subdivisions shall result in the creation of lots which are developable and capable of being built upon, unless a different purpose for the lot is clearly intended and approved by the planning commission or its designee. No subdivision shall create lots, and no building permit shall be issued for any lots which would make improvements and services impractical due to size, shape, steepness of terrain, location of watercourses, problems of sewerage or driveway grades, or other physical conditions.	The two proposed lots will have access to public streets and would be developable. There are no site features that would make service of improvements impractical.	Finding: Complies
E. Access To Public Streets:		
1. All lots or parcels created by the subdivision of land shall have access to a public street improved to standards required by this title, unless a private street or modified standards are approved by the planning commission as part of a planned development. Private streets shall not be permitted unless the planning commission finds that the most logical development of land requires that lots be created which are served by a private street or other means of access.	This subdivision amendment would only consolidate existing lots, not create any new ones. All proposed lots would have access to public streets.	Finding: Not Applicable
2. As part of the application for any subdivision proposing private streets, the subdivider shall provide for review by the city engineer the following:	No private streets proposed.	Finding: Not Applicable

<p>a. A street development plan showing the alignment, width, grades, design, and material specifications; the topography and means of access to each lot; drainage; and, utility easements for servicing the lots served by such private street.</p>	<p>No new streets proposed.</p>	<p>Finding: Not Applicable</p>
<p>b. A plan providing for future ownership and maintenance of said street together with payment of taxes and other liability thereon.</p>	<p>No new streets proposed</p>	<p>Finding: Not Applicable</p>
<p>3. After review and favorable recommendation by the city engineer, the planning commission may include such approved street plans as part of its recommendations to the mayor. Construction of the private street or access shall be completed prior to occupancy of any building on lots served by a private street. However, if finished grading has been completed and stabilized to the city engineer's satisfaction, the subdivider may post a cash bond equal to the cost of completing the street, as determined by the city engineer, in a form approved by the city attorney to assure the earliest possible completion of said street. The bond may be posted if, and only if, the street is stabilized and made passable until such time as the completion of the street can be accomplished.</p>	<p>No private or public streets are proposed as part of this subdivision amendment.</p>	<p>Finding: Not Applicable</p>
<p>F. Landscaping</p>		
<p>1. A landscaped area shall be required in all residential subdivisions and may be required in nonresidential subdivisions. Said landscaping shall be located either within the nonpaved portion of the street right of way, or within a dedicated landscaping easement, not less than five feet (5') wide, adjacent to the street. The location of the landscaping shall be specified by the planning commission or its designee. The type of landscaping and street trees shall be selected, installed, and maintained in accordance with standard specifications prepared by Salt Lake City.</p>	<p>The area within the subdivision amendment is zoned CG General Commercial. Therefore, this request is not a residential subdivision.</p>	<p>Finding: Not Applicable</p>
<p>2. Whenever, in the opinion of the planning commission or its designee, the cuts and fills created by the subdivision are of sufficient size or visibility to demand special treatment, the subdivider shall be required to landscape such areas with suitable permanent plant materials and to provide for their maintenance.</p>	<p>There are no changes in topography proposed as part of this request.</p>	<p>Finding: Not Applicable</p>
<p>G. Utilities and Easements:</p>		
<p>1. All utilities shall be provided through underground services.</p>	<p>No new utilities are proposed or necessary for this subdivision amendment.</p>	<p>Finding: Not Applicable</p>
<p>2. Easements for utility and drainage purposes shall be provided within the subdivision as required by the planning commission or its designee. However, in no event shall such easement be less than five feet (5') in width when proposed along the front lot line.</p>	<p>As requested by Public Utilities, the proposed easement is wider than 5 feet.</p>	<p>Finding: Complies</p>
<p>H. Watercourses:</p>		
<p>The subdivider shall dedicate a right of way for storm drainage conforming substantially with the lines of any natural watercourse or channel, stream, creek, or floodplain that enters or traverses the subdivision.</p>	<p>All existing stormwater drainage easements within the subdivision amendment will remain.</p>	<p>Finding: Complies</p>

A. Block Design:		
1. Blocks shall normally have sufficient width for an ultimate layout of two (2) tiers of lots of the size required by the provisions of the zoning and subdivision ordinances of Salt Lake City.	No new blocks are proposed as part of this request.	Finding: Not Applicable
2. Blocks shall not exceed the following perimeter measurements: Two thousand four hundred (2,400) linear feet for zoning districts with minimum lot sizes that range from no minimum up to and including ten thousand (10,000) square feet, and; three thousand (3,000) linear feet for zoning districts with a minimum lot size greater than ten thousand (10,000) square feet.	No new blocks are proposed as part of this request.	Finding: Not Applicable
J. Reservation Of Land For Park And Recreation Purposes: Pursuant to the recreation or parks elements, plans or standards set forth in the master plan, as a condition of final subdivision approval the subdivider shall be required to reserve land for park and recreation purposes according to the following standards:		
1. For subdivisions of twenty five (25) lots or more, including contiguous land owned or controlled by subdivider or landowner, the subdivider shall reserve land for two (2) years for public purchase at a minimum ratio of one-fourth ($\frac{1}{4}$) acre of land per twenty five (25) lots in the subdivision or five percent (5%) of the total area in the subdivision, whichever is greater.	This proposal includes fewer than 25 lots.	Finding: Not Applicable
2. All land to be reserved for park or recreational purposes shall be found to be suitable by the planning commission or its designee and the public services department as to location, parcel size, and topography for the park and recreation purpose for which it is indicated in the master plan, or as determined by the planning commission or its designee. Such purpose may include active recreation facilities such as playgrounds, play fields, pedestrian or bicycle paths, or open space areas of particular natural beauty, including canyons, hilltops, and wooded areas to be developed or left in their natural state.	No land is required to be reserved as park space.	Finding: Not Applicable
3. At the time of approval of the final subdivision plat, the city may specify when development of a park or recreation facility is scheduled to begin.	Not applicable	Finding: Not Applicable
K. Connectivity:		
1. Public Accessways:		
a. The city shall require within the development site the improvement of accessways for pedestrian and bicyclist use to connect the development site to adjacent cul-de-sacs or to an adjacent site that is undeveloped, publicly owned, or developed with an accessway that connects to the subject site.	No public accessway will be required as part of this proposal. Any adjacent site inaccessible to pedestrians or cyclists is State-owned right of way for either I-15 or the West Temple Viaduct.	Finding: Not Applicable
2. Street Connectivity Standards:		
a. The proposed subdivision shall include street connections to any streets that abut, are adjacent to, or terminate at the subdivision site. The proposed development shall also include street connections in the direction of all existing or planned streets adjacent to the development site as determined by the planning director.	No new streets are proposed as part of this request.	Finding: Not Applicable

<p>b. The proposed development shall include streets that extend to undeveloped or partially developed land that is adjacent to the development site or that is separated from the development site by a drainage channel, transmission easement, survey gap, or similar property condition. The streets shall be in locations that will enable adjoining properties to connect to the proposed development's street system.</p>	<p>No new streets are proposed as part of this request.</p>	<p>Finding: Not Applicable</p>
<p>3. Cul-De-Sacs:</p>		
<p>a. Except for streets that are less than one hundred fifty feet (150') long all streets that terminate shall be designed as a cul-de-sac bulb or other design acceptable to the transportation director in order to provide an emergency vehicle turnaround.</p>	<p>This proposal does not create any new cul-de-sacs.</p>	<p>Finding: Not Applicable</p>
<p>b. Public accessways to provide safe circulation for pedestrians, bicyclists and emergency vehicles shall be required from a cul-de-sac or emergency vehicle turnaround, unless the subdivider adequately demonstrates that a connection cannot be made because of the existence of one or more of the following conditions:</p> <p>(1) Physical conditions preclude development of the connecting street. Such conditions may include, but are not limited to, topography or likely impact to natural resource areas such as wetlands, ponds, streams, channels, rivers, lakes or upland wildlife habitat area, or a resource on the national wetland inventory or under protection by state or federal law.</p> <p>(2) Buildings or other existing development on adjacent lands, including previously subdivided but vacant lots or parcels, physically preclude a connection now or in the future, considering the potential for redevelopment.</p>	<p>This proposal does not create any new cul-de-sacs.</p>	<p>Finding: Not Applicable</p>
<p>20.12.020 Lot Design Standards: The size, shape and orientation of lots in a subdivision shall be appropriate to the location of the proposed subdivision and to the type of development contemplated. The following principles and standards shall be observed</p>		
<p>A. Minimum Area; Size: The minimum area and dimensions of all lots shall conform to the requirements of the zoning ordinances of Salt Lake City for the zoning district in which the subdivision is located.</p>	<p>No new lots would be created by this subdivision amendment.</p>	<p>Finding: Not Applicable</p>
<p>B. Side Lot Lines: The side lines of all lots, so far as possible, shall be designed to be at right angles to the street which the lot faces, or approximately radial to the center of curvatures, if such street is curved. Side lines of lots shall be designed to be approximately radial to the center of curvature of a cul-de-sac on which the lot faces.</p>	<p>All proposed lot lines are designed at right angles. Any irregular geometry is due to State-owned right of way.</p>	<p>Finding: Complies</p>

<p>C. Width: The minimum lot width shall conform to the requirements of the zoning district in which the proposed subdivision is located.</p>	<p>As proposed, the south property (1007 S 500 W) would have a lot width of 55 feet. However, the minimum in the CG district is 60 feet. Staff recommends as a condition of approval that the line dividing the north and south properties must be adjusted to ensure the south property meets this standard.</p>	<p>Finding: Complies with Conditions</p>
<p>D. Corner Lots: Corner lots have more than one side which must maintain required front yard setbacks, and therefore shall be platted wider than interior lots in order to permit conformance with the required street setback requirements of the zoning ordinance.</p>	<p>No corner lots are proposed.</p>	<p>Finding: Not Applicable</p>
<p>E. Remnants: No remnants of property shall be left in the subdivision which do not conform to the lot requirements or are not required or more suitable for designation as common open space, private utility, or other purpose.</p>	<p>All areas of the project site are accounted for as part of this proposal. No remnants of property would be left as part of this proposal.</p>	<p>Finding: Complies</p>
<p>F. Double Frontage Lots: Lots other than corner lots, having double frontage shall not be approved except where necessitated by topographic or other unusual conditions.</p>	<p>No double-frontage lots are proposed.</p>	<p>Finding: Not Applicable</p>

ATTACHMENT F: Street Vacation Considerations

In 1999, the City council adopted a policy for street closures (now known as vacations) that includes the following provisions:

- 1. It is the policy of the City Council to close public streets and sell the underlying property. The Council does not close streets when the action would deny all access to other property.**

Finding: Complies. The proposed vacation would not deny vehicular or pedestrian access to any nearby properties.

Discussion:

Brooklyn Avenue is abutted by two properties. The property to the south is owned by the applicant, and the owner of the north property has allowed the applicant to act as their representative for this request. Approval of this Street Vacation request would not deny access to other property. The two adjacent properties would maintain public access from 500 West.

Condition(s): None

- 2. The general policy when closing a street is to obtain fair market value for the land, whether the abutting property is residential, commercial, or industrial.**

Finding: Complies. The City would give up ownership of the Brooklyn Avenue right of way and obtain fair market value if it is sold to the applicants.

Discussion:

If approved by the City Council, the [Real Estate Services Division](#) would work with the applicant to sell the vacated property at fair market value. Planning Staff is confident that Real Estate Services staff will successfully negotiate a fair market value for the proposed vacation.

Condition(s): None

- 3. There should be sufficient public policy reasons that justify the sale and/or closure of a public street and it should be sufficiently demonstrated by the applicant that the sale and/or closure of the street will accomplish the stated public policy reasons.**

Finding: Complies With Conditions

Discussion:

As discussed in [Key Consideration 5](#), there are no adopted plans or policies that oppose the vacation of this section of Brooklyn Avenue. Policies within the draft updated Transportation Master Plan support this request, as long as the applicant provides the proposed easement along the edge of the I-15 and West Temple Viaduct right of way. In addition to the fair market value the city will receive for the request, the proposed easement could be an additional public benefit in exchange for the vacation.

Because of the freeway and West Temple Viaduct rights of way, Brooklyn Avenue currently only serves two properties. Any improvements such as paving, sidewalks, street trees, or otherwise would only benefit the owners of those two properties. Additionally, both properties are already sufficiently served by 500 West. In Planning staff's opinion, keeping Brooklyn Avenue as a public right of way would be a greater burden to the City in the long term than vacating it. To satisfy requirements set by the staff in the Engineering Division, the applicant agreed to install street improvements on the east side of 500 West and the south side of Fayette Avenue (according to specifications set by the Transportation Division) and a turnaround (that meets State Fire Code) whenever the vacated right of way is developed.

In Planning staff's opinion, the above-mentioned public benefits are sufficient policy reasons to approve the vacation of Brooklyn Avenue. The applicant has agreed to provide public benefits that meet the goals of multiple City Departments and Divisions (Public Utilities, Engineering, Transportation, and Fire).

Condition(s):

- Before the final plat vacating Brooklyn Avenue is recorded, the applicant will record a 15-foot-wide perpetual easement along the property lines abutting the storm sewer lines along the edge of the West Temple Viaduct right of way (as illustrated in the Exhibits included with [Attachment B](#)).
- After Brooklyn Avenue is officially vacated, city staff will record additional necessary sections of the easement within the vacated right of way prior to the official transfer of ownership to the applicant (as illustrated in the Exhibits included with [Attachment B](#)).
- The applicant will enter into an agreement with the City (through whatever method the City Council deems appropriate) that, upon any development of the Brooklyn Avenue right of way, they will install the following along the property frontages of 500 West and Fayette Avenue:
 - Curb and Gutter
 - Streetlights
 - Sidewalks
- The applicant will enter into an agreement with the City (through whatever method the City Council deems appropriate) that, upon any development of the Brooklyn Avenue right of way, they will install a turnaround that meets the fire code requirements at the time of development.

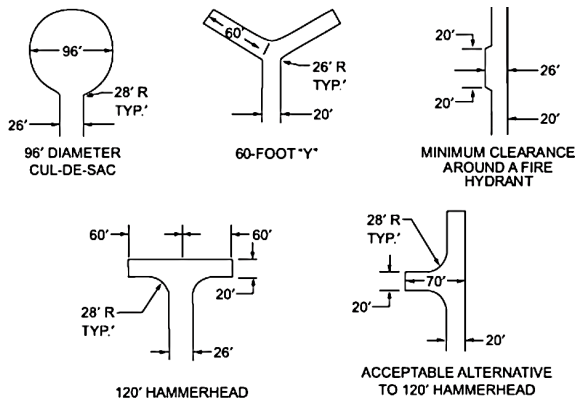

4. The City Council should determine whether the stated public policy reasons outweigh alternatives to the closure of the street.

Finding: Complies

Discussion:

In Planning staff's opinion, keeping Brooklyn Avenue as a public right of way would be a greater burden to the City in the long term than vacating it. Based on historical aerial photographs, it appears that Brooklyn Avenue has not been paved since I-15 was installed and, according to the applicant, has been plagued by crime, dumping, and encampments. The right of way is wider than most and, because of the freeway right of way, would only benefit two properties. Both adjacent properties are already sufficiently served by 500 West. The concessions proposed by the applicant and the fair market value of the potential sale appear to outweigh keeping the street open in the long term.

Condition(s): None

ATTACHMENT G: Alley Vacation Standards

14.52.020: Policy Considerations for Closure, Vacation, or Abandonment of City-Owned Alleys

The City will not consider disposing of its interest in an alley, in whole or in part, unless it receives a petition in writing which demonstrates that the disposition satisfies at least one of the following policy considerations:

14.52.020: The City will not consider disposing of its interest in an alley, in whole or in part, unless it receives a petition in writing which demonstrates that the disposition satisfies at least one of the following policy considerations:

- A. Lack of Use:** The City’s legal interest in the property appears of record or is reflected on an applicable plat; however, it is evident from an on-site inspection that the alley does not physically exist or has been materially blocked in a way that renders it unusable as a public right-of-way.
- B. Public Safety:** The existence of the alley is substantially contributing to crime, unlawful activity or unsafe conditions, public health problems, or blight in the surrounding area.
- C. Urban Design:** The continuation of the alley does not serve as a positive urban design element.
- D. Community Purpose:** The Petitioners are proposing to restrict the general public from use of the alley in favor of a community use, such as a neighborhood play area or garden.

Finding: Complies

Discussion:

On paper, the alley in question cuts right through the center of the applicant’s property (located at 1007 South 500 West). However, inspection of the site and historical aerial photographs show that the alley has not been in use since at least 1999. The alley has not physically existed for a significant period of time and has essentially functioned as part of the applicant’s property. Additionally, the alley terminates at the West Temple Viaduct right of way. Access to this right of way is limited to only freeway traffic, leaving the subject alley as a dead end.

The Alley Vacation request satisfies policy consideration **A, Lack of Use** since it 1) serves only one property, 2) has not physically existed and has been materially blocked off since at least 1999, 3) does not connect Brooklyn Avenue to another accessible public right of way.

Condition(s): None

14.52.030.B: Processing Petitions – Public Hearing and Recommendation from the Planning Commission. Upon receipt of a complete petition, a public hearing shall be scheduled before the Planning Commission to consider the proposed disposition of the City owned alley property. Following the conclusion of the public hearing, the Planning Commission shall make a report and recommendation to the City Council on the proposed disposition of the subject alley property. A positive recommendation should include an analysis of the following factors:

<p>1. The City Police Department, Fire Department, Transportation Division, and all other relevant City departments and divisions have no reasonable objection to the proposed disposition of the property;</p>
<p>Finding: Complies With Conditions</p>
<p>Discussion: City staff from all relevant departments and Divisions do not object to the proposed Alley Vacation request, provided the conditions related to the Street Vacation petition are met.</p>
<p>Condition(s): Conditions related to the Street Vacation petition must be met.</p>
<p>2. The petition meets at least one of the policy considerations stated above;</p>
<p>Finding: Complies</p>
<p>Discussion: The proposed vacation meets policy consideration A, Lack of Use.</p>
<p>Condition(s): None</p>
<p>3. Granting the petition will not deny sole access or required off street parking to any property adjacent to the alley;</p>
<p>Finding: Complies</p>
<p>Discussion: The subject alley serves only the applicant’s property, which already has access to a public street. Any required off-street parking on the adjacent property would not be affected by the vacation of this alley.</p>
<p>Condition(s): None</p>
<p>4. Granting the petition will not result in any property being landlocked;</p>
<p>Finding: Complies</p>
<p>Discussion: The only adjacent property (owned by the applicant) would not be landlocked if the alley were vacated.</p>
<p>Condition(s): None</p>
<p>5. Granting the petition will not result in a use of the alley property which is otherwise contrary to the policies of the City, including applicable master plans and other adopted statements of policy which address, but which are not limited to, mid block walkways, pedestrian paths, trails, and alternative transportation uses;</p>
<p>Finding: Complies</p>
<p>Discussion: The Ballpark Station Area Plan defers all long-range planning of the Granary District (where the alley is located) neighborhood to the Downtown Master Plan. In that plan, there is no mention of or planned uses for the subject alley. Vacating it would not be contrary to relevant adopted city plans or policies.</p>
<p>Condition(s): None</p>

6. No opposing abutting property owner intends to build a garage requiring access from the property, or has made application for a building permit, or if such a permit has been issued, construction has been completed within twelve (12) months of issuance of the building permit;

Finding: **Complies**

Discussion:

The only abutting property is owned by the applicant, who does not intend to use the alley as access for a future garage.

Condition(s): None

7. The petition furthers the City preference for disposing of an entire alley, rather than a small segment of it; and

Finding: **Complies**

Discussion:

The entire length of the subject alley would be vacated by approval of this request. No segment would remain.

Condition(s): None

8. The alley property is not necessary for actual or potential rear access to residences or for accessory uses.

Finding: **Complies**

Discussion:

The only abutting property is owned by the applicant and will not be necessary to access any actual or potential residences or accessory use

Condition(s): None

ATTACHMENT H: Subdivision Standards

20.16.100: All preliminary plats for subdivisions and subdivision amendments shall meet the following standards:

Standards of Review – Subdivision
A. The subdivision complies with the general design standards and requirements for subdivisions as established in chapter 20.12 of this title;
<p>Discussion: The proposal generally meets relevant design standards found in chapter 20.12 of the subdivision regulations, with the exception of 20.12.020.C: Lot Width. As discussed in Key Consideration 6, staff recommends that the lot line dividing Lot 1 and Lot 2 be adjusted on the final plat so that Lot 2 (the south lot) meets the minimum lot width requirement in the CG General Commercial Zoning District.</p>
<p>Condition(s): On the Final Plat, the lot line dividing Lot 1 and Lot 2 must be adjusted so that Lot 2 (1007 S 500 W) meets the minimum lot width requirements in the CG General Commercial Zoning District.</p>
<p>Finding: <input type="checkbox"/> Complies <input checked="" type="checkbox"/> Complies with conditions <input type="checkbox"/> Does not comply <input checked="" type="checkbox"/> Not Applicable</p>
B. All buildable lots comply with all applicable zoning standards;
<p>Discussion: As discussed under Standard A above, the proposed dimensions of Lot 2 (the south lot) do not meet the minimum lot width requirements in the CG General Commercial Zoning District. To ensure that the proposed subdivision amendment meets all applicable zoning standards, staff recommends that the lot line dividing the north and south lots is adjusted on the final plat so that the south lot meets the minimum lot width requirement.</p>
<p>Condition(s): On the Final Plat, the lot line dividing Lot 1 and Lot 2 must be adjusted so that Lot 2 (1007 S 500 W) meets the minimum lot width requirements in the CG General Commercial Zoning District.</p>
<p>Finding: <input type="checkbox"/> Complies <input checked="" type="checkbox"/> Complies with conditions <input type="checkbox"/> Does not comply <input type="checkbox"/> Not Applicable</p>
C. All necessary and required dedications are made;
<p>Discussion: No dedications of property are required for this development.</p>
<p>Condition(s): None</p>
<p>Finding: <input type="checkbox"/> Complies <input type="checkbox"/> Complies with conditions <input type="checkbox"/> Does not comply <input checked="" type="checkbox"/> Not Applicable</p>
D. Water supply and sewage disposal shall be satisfactory to the public utilities department director;
<p>Discussion: Public Utilities has provided preliminary approval. Additional utilities may be required if either Lot 1 or Lot 2 were to be developed, but that will be enforced at the time of development.</p>
<p>Condition(s): None</p>
<p>Finding: <input checked="" type="checkbox"/> Complies <input type="checkbox"/> Complies with conditions <input type="checkbox"/> Does not comply <input type="checkbox"/> Not Applicable</p>
E. Provisions for the construction of any required public improvements, per section 20.40.010 of this title, are included;
<p>Discussion: The proposed subdivision amendment does not create any new lots and therefore does not qualify as a “subdivision” as defined by the Salt Lake City Subdivision Ordinance since it does not include plans to divide or develop the land. Therefore, the requirements in 20.40.010 do not apply in this case.</p>

However, since the amendment includes vacated right of way, it must comply with policy set by all City divisions (as discussed under Standard G and in [Attachment F](#)). The applicant has agreed to have public improvements installed once the Brooklyn Avenue Right of way is developed and closed to the public. The relevant Divisions (Engineering, Transportation and Fire) support the proposed amendments, so this requirement will be met.

Condition(s): Conditions related to the Street Vacation petition must be met.

Finding: Complies Complies with conditions Does not comply Not Applicable

F. The subdivision otherwise complies with all applicable laws and regulations;

Discussion: with the exception of the minimum lot width, staff has not identified any issues with other applicable laws or regulations.

Condition(s): On the Final Plat, the lot line dividing Lot 1 and Lot 2 must be adjusted so that Lot 2 (1007 S 500 W) meets the minimum lot width requirements in the CG General Commercial Zoning District.

Finding: Complies Complies with conditions Does not comply (requesting modifications) Not Applicable

G. If the proposal is an amendment to an existing subdivision and involves vacating a street, right of way, or easement, the amendment does not materially injure the public or any person who owns land within the subdivision or immediately adjacent to it and there is good cause for the amendment.

Discussion:

Brooklyn Avenue serves only two properties, and the owners of both properties are applicants connected to this request. No other parties will be affected by this request. Brooklyn Avenue and the adjacent avenue terminate at State-owned freeway right of way that limits public access to highway traffic. Neither Brooklyn Avenue, nor the alley serve any other property within or adjacent to the Dolan and Brooklyn Subdivisions. Additionally, neither serves a significant benefit to the public since installing a functioning crossing underneath the freeway right of way is likely prohibitively expensive due to the width.

The applicant's concessions are also good cause for the proposal since they fulfill goals set by multiple City Departments and Divisions, including Public Utilities, Engineering, Transportation, and Fire (See Staff's analysis in [Attachment F](#) for additional discussion regarding the policy considerations for the request).

Condition(s):

- Before a final plat vacating Brooklyn Avenue is recorded, the applicant will record a 15-foot-wide perpetual easement along the property lines abutting the storm sewer lines along the edge of the West Temple Viaduct right of way (as illustrated in the Exhibits included with [Attachment B](#)).
- After Brooklyn Avenue is officially vacated, city staff will record additional necessary sections of the easement within the vacated right of way prior to the official transfer of ownership to the applicant (as illustrated in the Exhibits included with [Attachment B](#)).
- The applicant will enter into an agreement with the City (through whatever method the City Council deems appropriate) that, upon any development of the Brooklyn Avenue right of way, they will install the following along the property frontages of 500 West and Fayette Avenue:
 - Curb and Gutter
 - Streetlights
 - Sidewalks

- The applicant will enter into an agreement with the City (through whatever method the City Council deems appropriate) that, upon any development of the Brooklyn Avenue right of way, they will install a turnaround that meets the fire code requirements at the time of development.

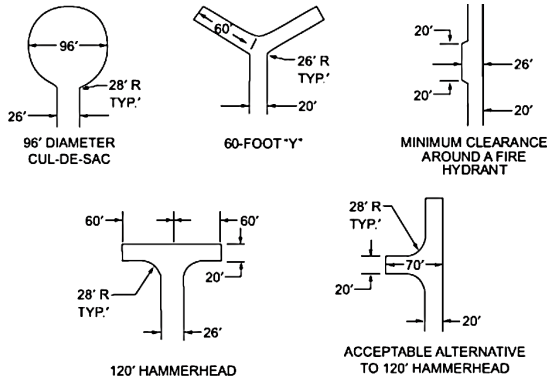

Finding: Complies Complies with conditions Does not comply Not Applicable

ATTACHMENT I: Public Process & Comments

Public Notice, Meetings, Comments

Initially, the applicant requested to vacate only the south half of Brooklyn Avenue, Planning Staff provided the following public input opportunities related to the proposed project.

- April 13, 2022
 - Notice to solicit comments was sent to the chairs of the Ballpark and Glendale Community Councils, starting the 45-day required early engagement period for the recognized community organizations.
- April 13, 2022
 - Notice of the proposal was sent to all property owners and occupants within 300 feet of Brooklyn Avenue and the adjacent alley.
- April 2022
 - The proposal was posted to the [Online Open House](#) webpage.

Later in 2022, the owner of 1005 South 500 West (the property to the north of Brooklyn Avenue), asked to be included in the request and the Street Vacation petition was modified to include all of Brooklyn Avenue. Upon receipt of the update, Planning staff provided the following public input opportunities:

- August 23, 2022
 - A notice with the updated information was sent to the chairs of the Ballpark and Glendale Community Councils, restarting the 45-day required early engagement period for the recognized community organizations.
- August 23, 2022
 - An updated notice of the proposal was sent to all property owners and occupants within 300 feet of Brooklyn Avenue and the adjacent alley.
- August 2022
 - The post on the [Online Open House](#) webpage was updated.

Notice of the public hearing for the proposal included:

- November 30, 2023
 - Public hearing notice mailed.
 - Public notice posted on City and State websites and Planning Division listserv.
- December 1, 2023
 - Public hearing notice sign posted on the property.
- December 3, 2023
 - Legal notice published in the Sunday Print Edition of the Salt Lake Tribune.

Public Input:

The Ballpark Community Council asked the applicant to attend one of their meetings. However, due to scheduling conflicts and higher-priority projects within the Ballpark neighborhood, the Chair and the applicant were unable to schedule the request.

ATTACHMENT J: Department Review Comments

This proposal was reviewed by the following departments. The proposal will need to comply with any requirement identified by a City Department or Division.

Engineering (Scott Weiler):

Below is a general summary of what is necessary to approve the vacation of Brooklyn Ave. Since the applicant told us that the property on the west side of 500 West could be developed, I don't think we need to require curb & gutter on the west side of 500 West as a condition of approval of this vacation request. A similar situation exists on Fayette Ave., where the West Village developer will install curb & gutter and sidewalk on the north side.

- Curb & gutter on the property frontages of Fayette Ave. and 500 West
- Streetlights on the property frontages of Fayette Ave. and 500 West
- Sidewalk on the property frontages of Fayette Ave. of 500 West
- hammerhead on 500 West, which requires additional R/W to be dedicated for public use to accommodate the 120' east/west dimension of the hammerhead. That would presumably come entirely from this applicant unless this applicant can persuade the property owner on the west side of 500 West to also dedicate land for the hammerhead.

Fire (Douglas Bateman):

A turnaround will be required at the end of 500 West. See IFC Appendix D for approved turn around. If hammerhead is used, the turn areas are increased to 80-feet (160-feet total) to accommodate SLC FD apparatus.

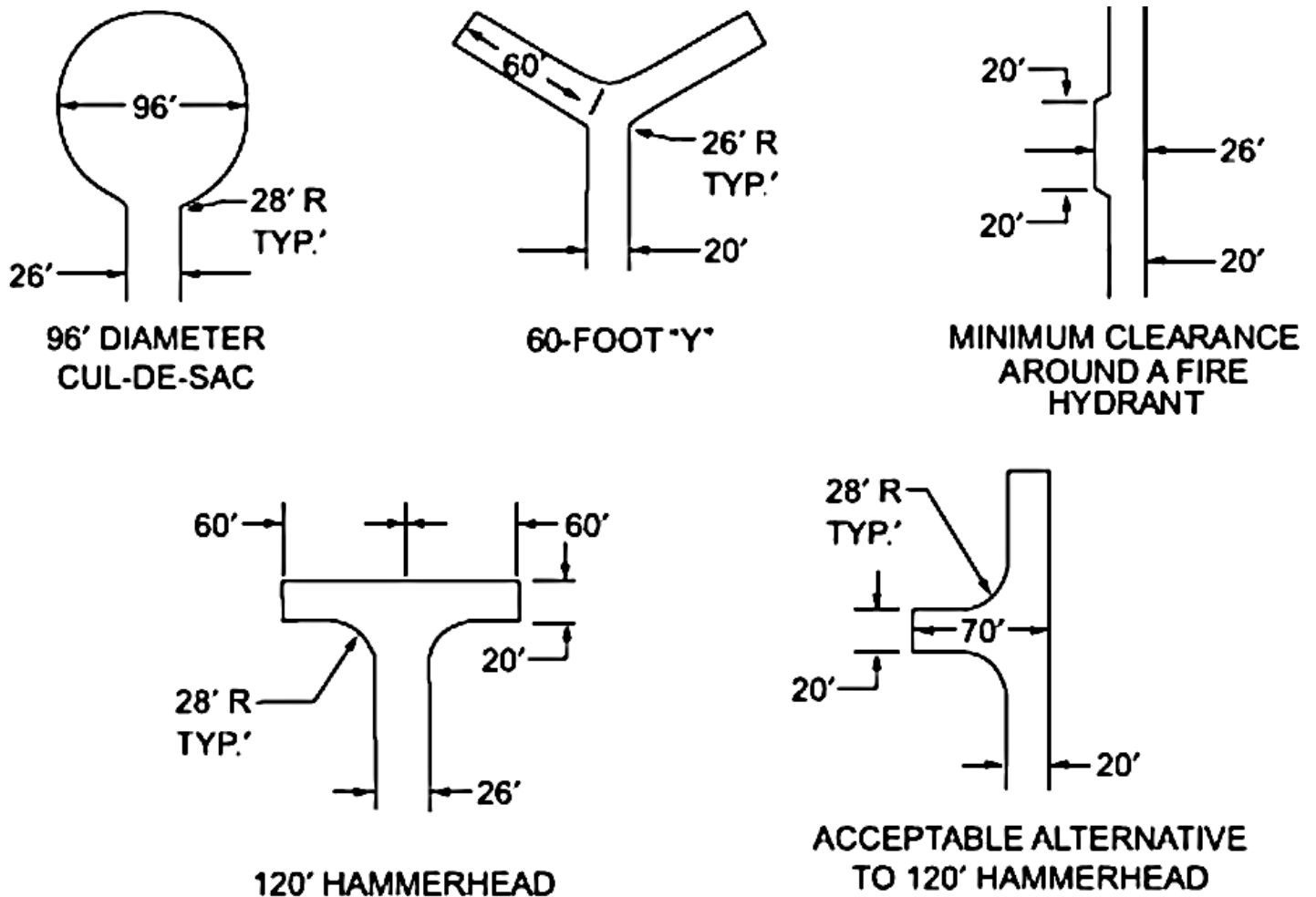

Transportation (Jena Carver):

The street vacation of Brooklyn Avenue would leave 500 W a dead-end street with no public turn-around. Because of the site limitations and the fact that 500W/Brooklyn is already a dead-end with no turn-around I recommend a public

hammerhead turn-around be provided before Brooklyn Avenue can be vacated. I also recommend full roadway improvements, including curb, gutter, and sidewalk, on all public street frontages. They should contact me to discuss the roadway improvement requirements, including the cross section, as well as the turn-around requirements. I have no issues with the alley vacations.

My primary concern with the public improvements is the cross section of Fayette Avenue. The property to the north will be installing curb and gutter and are using the Urban Village Street typology (type 8) as guidance. The curb and gutter on the south side will need to be placed to assure that the asphalt width is a minimum of 20 feet, with additional width possibly required by fire for aerial access to either their building or the building being built to the north. The 500 West cross section will also need to meet fire department requirements for the width and the turnaround design.

Public Utilities (Kristeen Beitel):

Please verify that the entry, book, and page numbers are included on the plat for the new storm drain easement before submitting for final plat review. **Public Utilities will not sign the final plat until the storm drain easement is recorded and noted on the plat.**

The floodplain must be shown on the final plat. Please use FEMA maps to accurately depict the boundary of the floodplain on the plat. Most of these lots are in a Zone AH flood zone, but some of the property is in Zone X. Both flood zones must be clearly shown, labelled, and delineated on the final plat. Additionally, the Base Flood Elevation (BFE) of the Zone AH must be noted on the plat.

Police (Andrew Cluff):

I don't have any issues with the closure so long as the management of the location falls back on the property owners. We do have transient related safety concerns in that immediate area, refuse being left, criminal activity, damaged property and the like are regular occurrences there.