

**HISTORIC LANDMARK COMMISSION
STAFF REPORT**



Planning Division
Department of Community and
Economic Development

**REVISIONS TO THE RESIDENTIAL DESIGN
GUIDELINES FOR HISTORIC DISTRICTS AND
LANDMARK SITES
PLNPCM2011- 00471
H-Historic Preservation Overlay District
December 15, 2011**

Applicant:

Mayor Ralph Becker

Staff:

Carl Leith

Carl.Leith@slcgov.com

(801)535-7758

Zone:

H-Historic Preservation Overlay
District

Council District:

N/A

Applicable Land Use

Regulations:

- 21A.34.020

Notification:

- Notice mailed on 12/8/11
- Agenda posted on the
Planning Division and Utah
Public Meeting Notice
websites 12/8/11

Attachments:

- Final Draft – Design
Guidelines for Historic
Residential Properties in
Salt Lake City
- HLC Public Hearing:
December 1, 2011 –
Minutes (extract)
- Open City Hall Online
Forum Report

Request

A petition initiated by Mayor Ralph Becker to revise the Design Guidelines for Residential Historic Districts in Salt Lake City regulated by the H Historic Overlay Zone.

Recommendation

That the Historic Landmark Commission reviews this Draft of the revised Residential Design Guidelines for Historic Districts and Landmark Sites, together with public comments received, closes the public hearing, and forwards a favorable recommendation for the adoption of these guidelines to City Council.

Introduction

The objective of the revision of the Design Guidelines for Historic Residential Properties in Salt Lake City is to bring these design guidelines into line with preservation guidelines best practice, to update and supplement the information and guidance provided, and to enhance the clarity and usability of the document as a resource for all concerned with the city's historic cultural resources. The guidelines will be organized and formatted to be readily available in digital form on the city website.

This report introduces the Final Draft of the revised Residential Design Guidelines for Historic Properties in Salt Lake City. This draft includes all sections of the future guidelines, with the exception of a forthcoming section addressing the character and additional design guidelines for Westmoreland Place. This will be completed in the course of the coming year.

This Draft has been revised to address comments raised at the Commission's meeting on December 1, 2011, and subsequently by the Historic Landmark Commission Design Guidelines Sub-Committee on December 5, 2011. The few matters that have not been fully addressed at this stage and will be identified for further consideration in revisions over the coming year. Further edits and refinements, focusing on illustrations and information sources, will be made to the draft before and after adoption by City Council. Staff will continue to address comments received and outstanding issues during the course of 2012 to achieve a more refined and usable series of design guidelines.

The residential guidelines will be supplemented by separate Appendices covering Design Review and Procedure. Appendices covering a Glossary of Terms and Historic Preservation Resources Links have been prepared for this final draft. The Appendices will be a common resource serving all three sets of design guidelines.

In this final draft the design guidelines have been re-organized in four parts. The previous introductory chapter, Preservation in Salt Lake City, has been revised as three individual short chapters and linked with the fourth chapter on Historic Context and Architectural Styles, to form Part I of the guidelines. Part II now covers all the Design guidelines for Rehabilitation, General Issues, and New Construction, in a series of twelve chapters. Part III includes the history, characteristics and supplementary guidelines for The Avenues, Capitol Hill, Central City, South Temple and University, with Westmoreland Place to follow during the coming year.

Background

The Commission reviewed the First Draft of the Residential Design Guidelines at a public hearing on November 17, 2011, received public comments and discussed a range of issues. A series of revisions were made to the guidelines for the second draft. The public hearing was continued to December 1 meeting, when the Commission reviewed Draft 2 of the guidelines. With additional suggestions for revisions, additions and improvements, the Commission resolved to continue the public hearing to the meeting on December 15. Members of the Commission forwarded some detailed comments and 'mark-ups' to Staff for their review.

The Sub-Committee on the residential design guidelines met on December 5, and discussed several issues in greater detail. As a result Staff has produced this 'final' draft which incorporates a series of revisions, some mentioned above, and all identified in greater detail below. The Minutes of the commission meeting December 1 are attached to this report as Attachment B.

To recap on this process briefly, the first draft of nine chapters of the Residential Design Guidelines covering rehabilitation issues, was reviewed at a Commission work session on October 20, 2011. The Commission made

a series of valuable observations, with several members forwarding detailed comments to Staff. The Residential Design Guidelines Subcommittee met on November 2, 2011 and reviewed a series of issues raised at previous Commission meetings and in the comments made on the first nine chapters.

Earlier the Commission discussed the Issues, Objectives and Content of the proposed revision of the Residential Design Guidelines at a work session on September 1. The proposed revisions to the design guidelines were introduced and discussed in a work session on May 5, 2011, which addressed the goals for the revisions for Residential, Commercial and Sign Design Guidelines.

Public Comment

The proposed objectives and revisions to the Residential Design Guidelines have been presented at two Public Open House evenings on September 12 and October 27, 2011. Several inquiries have also been received to date by email and telephone, although further comment received has been limited.

A copy of each draft has been posted on the City Planning webpage on Preservation Program Improvements as these become available. All inquiries received have been referred to this City webpage and one copy of the first draft has been sent out in the post. All have been kept in touch with the process. This City Web Page on Preservation Program improvements has this latest draft of the guidelines. Additional comments have been received from the Utah Heritage Foundation, and from staff.

The Residential Design Guidelines Revisions have been posted as a topic on the City's Open City Hall Online Public Forum since November 21. The link on this topic has directed the public to the current draft. The topic has received respectable attention, attended by 287 people, with 7 comments posted. A report is attached as Attachment C of this staff report.

Points to Note

Points to note in this further and final draft include the following:

- The reorganization of the guidelines document into four distinct Parts, to achieve greater clarity and coherence. These are:
 - I. Preservation in Salt Lake City, including:
 1. Why Preserve Historic Buildings and Neighborhoods?
 2. The Preservation Program in Salt Lake City – Defining and Managing Historic Buildings and Districts
 3. The Design Guidelines – Why? What? How?
 4. Historic Context and Architectural Styles
 - II. Design Guidelines: Rehabilitation / General Issues / New Construction
 - Ch. 1-10 Rehabilitation
 - Ch. 11 General Issues
 - Ch. 12 New Construction
 - III. Design Guidelines: Historic Districts
 - IV. Appendices
- Complete revision of the previous introductory chapter to form three shorter chapters as outlined above, linked to the previous Historic Context and Architectural Styles. Additional text to cover reference to the Commercial and the Signs guidelines. Additional text in the Why Preserve chapter. Minor edits elsewhere.
- Addition of a detailed Table of Contents Index, identifying the sections and topics through the document, to enhance usability and navigation.

- Some additional text to address advice on rooftop additions.
- Additional text to address a progression of spaces in Chapter 1.
- Edits to illustrations and captions in several parts of the document.
- Refinement of the Glossary of Terms section.
- Addition of a Historic Preservation Resources section
- Additional advice notes on lead-based paint in Chapters 2 & 3.
- Additional energy efficiency note in Chapter 3.

Considerations

The Commission is asked to review this draft of the design guidelines in detail, to close this public hearing and to consider approving this draft, with revisions as the Commission might identify, for consideration by City Council.

Attachment A

FINAL DRAFT – DESIGN GUIDELINES FOR HISTORIC RESIDENTIAL PROPERTIES IN SALT LAKE CITY December 8, 2011



Design Guidelines
for Historic
Residential Properties
in Salt Lake City

FINAL DRAFT - December 8, 2011

PART I - PRESERVATION IN SALT LAKE CITY

1. Why Preserve Historic Buildings & Neighborhoods?

- Culture, Quality of Life & Livability
- A Sense of History, Identity & Beauty
- Economic Vitality & Employment
- Mobility & Transportation
- Sustainability & the Environment
- The Quality of Design & Construction
- Adaptability

2. The Preservation Program in Salt Lake City – Defining & Managing Historic Buildings & Districts

- The Historic Preservation Plan - Draft
- National & Local Register Designations
- Certified Local Government Status
- Policies & Ordinance Standards Underlying the Design Guidelines
- Additional Incentives for Preservation
- Preservation Design Standards & Guidelines

3. The Design Guidelines

Why Have Historic Preservation Design Guidelines?

Basic Preservation Theory

- The Concept of Historic Significance
- The Concept of Integrity

Historic Preservation Principles

- Respect Historic Character
- Seek Compatible Uses
- Protect & Maintain Significant Features
- Preserve Original Features & Materials
- Repair First

Selecting a Preservation Approach

- Adaptive Use
- Maintenance
- Preservation
- Rehabilitation
- Renovation
- Restoration
- Remodeling
- Combining Preservation Strategies

How to Use the Design Guidelines

- Arrangement & Format of Document & Chapters
- Arrangement & Format of the Historic District Chapters
- Format of a Design Guideline

Additional Information & Resources

4. Historic Context and Architectural Styles

PART II - DESIGN GUIDELINES: REHABILITATION / GENERAL / NEW CONSTRUCTION

Chapter 1 Site Features

Context and Character	1:1
Design Objective	1:1
General	1:2
1.1	1:2
Historic Fences	1:2
1.2 – 1.5	1:3
Historic Grading	1:4
1.6	1:4
Masonry Retaining Walls	1:5
1.7 – 1.10	1:6
Walkways & Sidewalks	1:8
1.11 – 1.12	1:9
Driveways	1:9
Park strips	1:10
Landscaped Medians or Parkways	1:10
Planting Designs & Materials	1:11
1.13	1:11
Street Lighting	1:12
1.14 – 1.15	1:12
Site Lighting	1:12
1.6	1:12

Chapter 2 Building Materials and Finishes

Context and Character	2:1
General	2:3
2.1	2:3
Masonry	2:3
2.2 – 2.7	2:5
Wood	2:7
2.8 – 2.11	2:8
Metal	2:9
2.12 – 2.13	2:9
Cleaning	2:10
2.14 – 2.15	2:10
Repair	2:11
2.16 – 2.18	2:11
Paint & Other Coatings	2:12
2.19 – 2.21	2:13
Additional Information	2:14

Chapter 3 Windows

Context and Character	3:1
Design Objective	3:1
Window Features	3:2
Window Types	3:2
Window Deterioration	3:2
Window Repair	3:4
3.1 – 3.2	3:5
Energy Conservation	3:6
3.3	3:7
Replacement Windows	3:7

	3.4 – 3.8	3:9
	Additional Information	3:10
Chapter 4	Doors	
	Context and Character	4:1
	Design Objective	4:1
	4.1 – 4.2	4:1
	Maintaining a Historic Door	4:2
	Repairing of Historic Doors	4:2
	Energy Conservation	4:5
	Replacement	4:6
	4.3 – 4.4	4:6
Chapter 5	Porches	
	Context and Character	5:1
	Design Objective	5:1
	Porch Features	5:2
	Porch Deterioration	5:2
	5.1 – 5.2	5:3
	Porch Alterations	5:4
	Porch Repair	5:4
	Porch Replacement	5:5
	5.3 – 5.4	5:6
	Additional Information	5:6
Chapter 6	Architectural Details	
	Context and Character	6:1
	Design Objective	6:1
	6.1 – 6.2	6:1
	Replacement Materials	6:2
	Additional Information	6:4
Chapter 7	Roofs	
	Context and Character	7:1
	Roof Deterioration	7:1
	Design Objective	7:2
	7.1 – 7.2	7:2
	Roof Materials	7:3
	7.3	7:4
	Gutters & Downsprouts	7:5
	Roofs on Additions	7:6
	7.4 – 7.6	7:6
	Additional Information	7:8
Chapter 8	Additions	
	Context and Character	8:1
	Design Objective	8:1
	Existing Additions	8:1
	Basic Principles for New Additions	8:2
	8.1 – 8.10	8:3
	Rooftop or Attic Additions	8:6
	8.11 - 8.13	8:6
	Ground Level Additions	8:7
	8.14 – 8.16	8:7
	Additional Information	8:8
Chapter 9	Accessory Structures	

	Context and Character	9 : 1
	Design Objective	9 : 1
	History of Secondary Structures	9 : 2
	Preserving & Rehabilitating Historic Accessory Structures	9 : 3
	Primary Materials	9 : 3
	Roof Form & Materials	9 : 3
	9.1 – 9.3	9 : 3
	Additional Information	9 : 4
Chapter 10	Seismic Retrofitting	
	Context and Character	10 : 1
	Design Objective	10 : 1
	10.1	10 : 1
	Additional Information	10 : 2
Chapter 11	General Issues	
	Color	11 : 3
	11.1 – 11.2	11 : 4
	Accessibility	11 : 4
	11.3	11 : 5
	Mechanical Equipment	11 : 5
	11.4 – 11.5	11 : 6
	Landscaping	11 : 7
	11.6 – 11.8	11 : 7
	Service & Parking Areas	11 : 7
	11.9 – 11.12	11 : 7
	Additional Information	11 : 7
Chapter 12	New Construction	
	District Street Patterns	12 : 4
	12.1 – 12.2	12 : 4
	Building Orientation	12 : 6
	12.3	12 : 6
	Mass & Scale	12 : 6
	12.4 – 12.6	12 : 6
	Building Height	12 : 7
	12.7 – 12.8	12 : 7
	Building Width	12 : 8
	12.9	12 : 8
	Building Form	12 : 8
	12.10 – 12.11	12 : 8
	Proportion of Facade Elements	12 : 9
	12.12	12 : 9
	'Solid to Void' Ratio	12 : 9
	12.13	12 : 9
	Rhythm & Spacing Windows & Doors	12 : 10
	12.14	12 : 10
	Materials	12 : 10
	12.15 – 12.16	12 : 10
	Architectural Character	12 : 11
	12.17 – 12.20	12 : 11
	Windows	12 : 12
	12.21 – 12.23	12 : 12

PART III - DESIGN GUIDELINES: HISTORIC DISTRICTS

The Avenues

Historic Architectural Character	A : 3
Canyon Road and Memory Grove	A : 8
Development Trends	A : 8
Characteristics of the Avenues	A : 9
Characteristics of Canyon Road and Memory Grove	A : 9
Goals for the District	A : 9
Streetscape Features	A : 10
Park strips and Street Trees	A : 10
Walkways	A : 10
Site Design Features	A : 11
Front Setback	A : 11
Side Setback	A : 11
Accessory Structures	A : 12
Landscape Design Features	A : 12
Fences and Retaining Walls	A : 12
Architectural Features	A : 13
Building Form	A : 13
Building Materials	A : 14
Appropriateness of Use	A : 14

Capitol Hill

Historic Architectural Character	CH : 3
Development Trends	CH : 7
Characteristics of Capitol Hill	CH : 8
Goals for the District	CH : 8
Streetscape Features	CH : 9
Walkways	CH : 9
Street Pattern	CH : 9
Site Design Features	CH : 9
Front Setbacks	CH : 9
Orientation	CH : 10
Landscape Design Features	CH : 11
Fences and Retaining Walls	CH : 11
Architectural Features	CH : 12
Building Form	CH : 12
Building Materials	CH : 12

Central City

Historic Architectural Character	CC : 3
Development Trends	CC : 6
Characteristics of Central City	CC : 7
Goals for the District	CC : 7
Streetscape Features	CC : 8
Street Pattern	CC : 8
Landscape Features - Fences	CC : 8
Site Design Features	CC : 9
Front Setback	CC : 9
Porches	CC : 9
Architectural Features	CC : 10
Additions / Alterations	CC : 10
Building Mass	CC : 10

Building Scale	CC: 11
Building Form	CC: 11
Building Materials	CC: 11
Commercial Area Features	CC: 12
South Temple	
Historic Architectural Character	ST: 3
Development Trends	ST: 5
Characteristics of South Temple	ST: 5
Goals for the District	ST: 6
Streetscape Features	ST: 6
Walkways	ST: 6
Site Design Features	ST: 7
Front Setback	ST: 7
Side Yard Setback	ST: 8
Curb Cuts	ST: 8
Service Areas	ST: 8
Sitting of Additions	ST: 8
Architectural Features	ST: 9
Porches	ST: 9
Ornamentation	ST: 9
Building and Roof Materials	ST: 10
Appropriateness of Use	ST: 10
University	
Historic Architectural Character	U: 3
Development Trends	U: 5
Characteristics of University	U: 5
Goals for the District	U: 6
Streetscape Features	U: 6
Street Pattern	U: 6
Alleys	U: 6
Architectural Features	U: 7
Building Form, Mass, Scale	U: 7
Porches	U: 8
Building and Roof Materials	U: 8
Westmoreland Place	
To be completed in 2012	

PART IV - APPENDICES

PART I
Preservation in Salt Lake City



DRAFT

Cover Images:

Above and below are before and after images, respectively, of the John and Emily Platts home at 364 Quince Street. Platts was an English stone mason who came to Salt Lake in 1854 and built this house four years later. When the current owners purchased the house in 1975 it was in the state of disrepair seen in the top photograph. Over the years, they have renovated it so that it is a functional house for their family, while preserving the historic character of the home.

1 Why Preserve Historic Buildings and Neighborhoods?

Across the nation, communities care for the historic resources which are essential to their identity and which define them as unique. They promote historic preservation because to do so is essential to cultural, social, economic and environmental sustainability. They are key ingredients in neighborhood livability and quality of life, minimizing negative impacts on the environment and yielding economic vitality and reward. In an increasingly fast-paced, anonymous and 'placeless' form of urban development, the individual character of each community is a precious identity, creating a sense of stability, and providing an understanding of how unique character, itself a product of incremental development over time, can provide a direction and inspiration for the form of future development.

Many residents and businesses are also drawn to historic houses and neighborhoods because the quality and richness of design, construction, craftsmanship and materials, are typically very high. These buildings are readily adaptable to contemporary needs. Salt Lake City is no exception, and has a series of unique and visually rich residential neighborhoods and commercial quarters.

The historic environment is the cultural landscape of our community. It represents the historical documentation of the incremental evolution of our society and neighborhoods. The pages of this 'document' of the city reflect the many thousands of decisions which have together created the city's urban environment, from a cultural legacy from many countries, and many families, and many skills, and many values.

CULTURE, QUALITY OF LIFE & LIVABILITY	2
A SENSE OF HISTORY, IDENTITY & BEAUTY	2
ECONOMIC VITALITY & EMPLOYMENT	3
MOBILITY & TRANSPORTATION	4
SUSTAINABILITY & THE ENVIRONMENT	4
THE QUALITY OF DESIGN & CONSTRUCTION	5
ADAPTABILITY	5

Culture, Quality of Life and Livability

When groups of older buildings occur as a historic district, they can create a local residential environmental character which is so much greater than the sum of its parts. It is defined on a human scale, which encourages walking and neighborly interaction. Mature trees and landscaping, stone walls and decorative architectural composition and features contribute to a sense of identity; an identity that is unique to each historic neighborhood, and a characteristic that is increasingly rare, and also almost impossible to achieve in a new urban area. This physical sense of neighborhood cohesion can enhance community stability, reinforce desirable social patterns and networks, and contribute to a sense of reassurance and security. Many residents of historic districts, for example, note how easily they get to know their neighbors, and enjoy the fact that they are recognized by others who live in the vicinity.

Often older homes and neighborhoods frequently provide a variety of accommodation at a range of scales, serving a spectrum of housing needs and desires. Within these neighborhoods many small enterprises were established, providing a variety of service needs and creating a rich legacy of architecture, usually as individual buildings designed in scale with the residential neighborhood. Many continue in commercial use today.

Maintaining these historic settlement patterns and original fabric preserves the "stage", from which to absorb, learn about and explore our culture. Our historic neighborhoods are effectively a kaleidoscope of local, regional and global family lineage and cultural backgrounds. This 'stage', or 'classroom' provides a foundation of knowledge for our future understanding, identity and achievement.

A Sense of History, Identity and Beauty

The recognition that humanity needs more to nurture the spirit, once the basic needs of existence and survival are met, is universally recognized. In its intangibility though, it is ill defined and respected in the pragmatic norms of our society. There is a need to enrich the everyday experience of live/work with cultural contact with a sense of history, time and beauty. Although this may vary by individual and background, and be more readily versed by some more than others, it remains an everyday need and quest, recognized or otherwise. The historic neighborhoods, quarters and buildings of Salt Lake City bring a concentration of interlaced time and beauty, a sense of maturity and permanence that is both experienced and elusive. A principal reason to live in one of the more historic parts of our city is not solely connected to proximity and property investment. It is also directly related to the values and experience we seek in visiting a historic city or site on vacation. It has to do with the elevation and refreshment of the spirit that comes from the experience of a living work of art and architecture, and being a part and caring for it.

Economic Vitality and Employment

Historic resources are finite and cannot be replaced, making them precious commodities that many hold in high regard today.

Preservation tends to enhance the attraction and value of neighborhoods and the value of private property. Many studies across the nation have documented that, where local historic districts are established, property values typically appreciate faster, or at very least are stabilized where they might have been previously depreciating. In this sense, designation of a historic district appears to help establish a climate for stability, and enhanced civic pride, and also for further personal investment in the area. Residents within the district know that the time and money they spend on improving their properties are likely to be matched with similar efforts on surrounding lots. These investments will not be undermined by over-scaled or otherwise inappropriate construction next door or nearby, and they tend to have a multiplier effect in terms of neighborhood character and desirability.

The condition of neighboring properties affects the value of one's own property. People invest in a neighborhood as much as in the individual structures themselves. A historic district investment is often more attractive, with property owners recognizing that each benefits from the commitment of their neighbors. An indication of the success of preservation would be the more than 1.4 million resources that are listed on the National Register; including, sites, districts, structures, and objects. [NPS, 6/2011, www.cr.nps.gov/nr/about.htm]

In terms of local economic vitality and employment, preservation projects contribute more to the local economy than do new building programs. Each dollar spent on a preservation project has a higher percentage devoted to labor, usually local skilled labor, and to the purchase of materials available locally. By contrast, new construction typically has a higher percentage of each dollar devoted to materials or components that are usually produced outside of the local economy, and merely assembled on site. Consequently, when money is spent on rehabilitating a building, it has a higher local "multiplier effect," keeping more money circulating for longer in the local economy, when compared with new construction.

Rehabilitating a historic building frequently costs less than constructing a new one, aside from the costs arising from any demolition. In fact, the guidelines for rehabilitation of historic structures presented in this document promote cost-saving measures. They encourage smaller and simpler solutions, which in themselves provide savings. Preserving building elements that are in good repair is preferred, for example, to replacing them. Preservation and repairs are also typically less expensive.

In some instances, however, appropriate restoration procedures may cost more than less sensitive treatments, although they may endure much longer. In such cases, property owners are compensated for this extra effort, to some extent, in the added value that historic district designation provides. Special economic incentives also exist to help offset potential added costs where they do arise.

Mobility and Transportation

Living in a more historic neighborhood helps reduce the city resident's dependence upon the car for everyday needs. Older neighborhoods are close to the business, cultural and employment concentrations in the downtown area; the very reasons prompting their initial development. Residents were and are able to live closer to where they work, avoiding or minimizing the need to use the car.

The greater concentration provided by these urban residential neighborhoods also enhances the economic viability of public transportation as a convenient and less expensive alternative to the car. This concentrated settlement pattern was initially directly influenced by the city's street car network, and now supports its re-emergence. There are the further benefits of enhanced air quality through a reduction in gasoline consumption and toxic exhaust emissions; poor air quality being a persistent issue along the Wasatch Front, from early development periods.

Sustainability and the Environment

Preserving a historic structure makes sound environmental conservation policy and practice.

Continuing a building in use is the ultimate in recycling since no demolition waste is generated, no processing of materials is required, and no energy consumed. No new construction materials are required, avoiding the energy, waste and pollution from manufacturing, and avoiding energy use for transportation and construction.

The embodied energy which was used to create the original building and its components, is preserved and reinvested. Old buildings have a great deal of embodied energy. The extraction and processing of building materials (e.g., wood, stone, and brick), the transportation of those materials, and the construction labor represented in the final structure, mean that demolition of an existing building and constructing anew is notably less energy-efficient than rehabilitating or constructing an addition for the existing building. Conserving a building preserves its embodied energy and reduces the need for new materials. Demolition waste which accounts for 25% of waste in municipal landfills every year.

Older buildings (up to 1920s) are, as a rule, as energy efficient as those buildings built today under increasingly stringent energy efficiency requirements, and more energy-efficient than buildings constructed from the 1920s to the 1990s. These inherent advantages can be further enhanced through the understanding of the materials, the construction and the essential qualities of traditional design and craftsmanship. Thick, heat-retaining walls in brick and stone, with access to natural ventilation, contribute to their excellent energy efficiency. Historic buildings can also be adapted to benefit from new technology in the form of solar panels or shingles.

The Quality of Design and Construction

Design, building and craft skills gradually focused in Salt Lake City from many parts of the world. New residents brought with them often centuries old traditions in construction and the arts, and often an appreciation of urban and architectural sophistication. This coincidence of culture, design and craft is reflected in the earlier development of the city.

Most of the historic structures in the city are of high design and construction quality. The wood used for example came from mature old growth trees, was carefully seasoned and was typically milled to full dimensions, yielding stronger and more durable framework, cladding, windows, trim and details. Masonry walls were carefully laid, resulting in buildings with considerable stability, and refined, precise detailing. Our historic buildings were thoughtfully and traditionally embellished and detailed, while the materials and finishes, including fixtures, wood floors and trim were generally of high quality; all characteristics which are now increasingly rare, and highly sought and appreciated.

By comparison, in today's new construction, materials of such quality are rarely available and comparable detailing, if achievable, is **very expensive**. The high quality of design and construction in historic buildings is consequently a significant asset, with notable durability and minimal basic maintenance.

Adaptability

Historic building floor plans tend to be readily adaptable, accommodating contemporary lifestyles and supporting a diversity of requirements. Rooms are frequently large, permitting a variety of uses, while retaining the overall historic character of each building. In residential areas private open space often exists on the lot to accommodate an addition, if needed. In commercial buildings the accommodation tends to be both flexible and varied, and usually comes with significant identity and character, factors which are usually very attractive for small business, their establishment and profile.

The Preservation Program in Salt Lake City – Defining and Managing Historic Buildings and Districts

The Historic Preservation Plan - Draft

The Historic Preservation Plan for Salt Lake City, developed over several years by consultants and the City, establishes city-wide policies, goals, objectives and action priorities for the Historic Preservation Program. This is the first such comprehensive review and evaluation of the program in Salt Lake City, and will provide common directions for future city policy. The Plan is currently (early 2012) in Draft form.

National & Local Register Designations

Like most communities, Salt Lake City has two categories of historic district and landmark sites. It is important to understand and distinguish the city's designation of historic districts through its local ordinance process, from historic designation to the National Register of Historic Places.

National Register of Historic Places

The National Register of Historic Places is a list of sites and properties of historic significance. Properties so listed may have national significance, but they may also be listed if they are determined to have significance at a state or local level. The National Register is administered by the National Park Service and nominations are submitted through the State Historic Preservation Officer, using criteria adopted by the Secretary of the Interior. Listing in the National Register is a recognition and status that is honorary and does not involve city review of proposed external alterations. National Register designation brings recognition, research knowledge and, in appropriate cases for buildings defined as 'contributing', Federal and State tax incentives.

HISTORIC PRESERVATION PLAN - DRAFT	7
NATIONAL & LOCAL REGISTER DESIGNATIONS	7
CERTIFIED LOCAL GOVERNMENT STATUS	8
POLICIES & ORDINANCE STANDARDS UNDERLYING THE DESIGN GUIDELINES	8
ADDITIONAL INCENTIVES FOR PRESERVATION	9
PRESERVATION DESIGN STANDARDS AND GUIDELINES	9

Properties listed on the National Register may be eligible for federal income tax credit incentives, and federal actions that may affect these properties must be re-viewed for their potential impact. Alterations are not reviewed if the property owner is not seeking the federal income tax incentive or if no federal actions are involved. Otherwise, there are no regulations governing compatible alterations, infill or demolition.

Local Historic Districts

The local designation process is established through the city's zoning ordinance. Criteria for designation are set forth in the City code and designated properties are subject to regulations outlined in the ordinance, including demolition, and design review standards for new construction and external alterations to existing buildings. These guidelines inform the design review process for external alterations, additions and new construction for local historic districts and City designated landmark buildings, providing detail, clarification and options for the design review standards in the ordinance. They also provide an information resource and guidance in planning a project affecting these areas, sites and buildings.

PART I Preservation in Salt Lake City

Certified Local Government (CLG) Status

Salt Lake City has agreed to support the principles of the Secretary of the Interior's Standards for Rehabilitation of Historic Buildings in a contract with the State Historic Preservation Officer. In that contract, the city received status as a "Certified Local Government," under the National Historic Preservation Act. This act provides that a local government, when it meets certain guidelines for operation of a preservation program, may become so certified and therefore become eligible for technical and financial assistance to administer its preservation activities.

Policies and Ordinance Standards Underlying the Design Guidelines

The forthcoming Historic Preservation Plan will provide comprehensive policy and an implementation action plan for the preservation program in the city, in the light of nationally accepted preservation standards and an evaluation of the current and potential historic and cultural resources of the city. The residential, commercial and sign design guidelines form a key part of the array of tools available to the City in the role of caring for these assets.

The design guidelines are founded on the goals for preservation as stated in the Salt Lake City Zoning Ordinance Title 21A of the Salt Lake City Code, Chapter 34.020 "Purpose Statement." These preservation goals provide direction to projects executed within the historic context of each district.

The guidelines are intended to be used in a number of ways: property owners and architects should use the guidelines when beginning a project; city staff will use the guidelines when advising property owners and in administrative reviews and the Historic Landmark Commission (HLC) will use the guidelines when considering the issuance of a Certificate of Appropriateness.

The guidelines are based on the criteria and design standards set forth in Chapter 34.020 of Title 21A, of the Salt Lake Code, the city zoning ordinance, which provides for the creation and management of historic preservation overlay districts.

The design guidelines, as well as the ordinance design standards, incorporate principles set out in the Secretary of the Interior's Standards for Treatment of Historic Properties, a nationally accepted set of basic preservation design standards and guidelines. It is the intent of this document to be compatible with the Secretary of the Interior's Standards, and to clarify, amplify and interpret those essential preservation principles whether at the project planning and design stage, or in the subsequent design review and approval process.

Compliance with the ordinance standards is enforced through the city's permitting and inspection processes, including the building permit review system. Property owners should recognize that most projects require a building permit, which is issued by the city's building official, in addition to the Certificate of Appropriateness that is issued by the HLC, or Planning Division staff on its behalf.

Additional Incentives for Preservation

While the economic benefits from historic district status are notable, special incentives also exist to help offset any added costs which might be associated with appropriate rehabilitation procedures. Income tax credits are offered at the state and federal levels for rehabilitation which meets certain standards. There are also tax incentives associated with a facade easement on a historic property. In some cases, the city can also provide special zoning incentives and can help to expedite development review associated with preservation projects. There are also other city programs which provide some financial assistance with rehabilitation projects. Additionally, the Utah Heritage Foundation has a low interest loan program for the rehabilitation of historic properties which meet their eligibility criteria.

Preservation Design Standards and Guidelines

The design standards in the City Ordinance provide the regulatory foundation for the review of proposals affecting the historic sites and districts in the city. [21A.34.020] They are brief and provide little detail as to their application in the context of the variety of circumstances which occur when designing a particular project for a particular house, in a particular district. The design guidelines provide the detailed guidance and advice on ways to meet the ordinance standards. They are necessarily flexible, enabling them to relate to a spectrum of conditions which will arise with the unique nature of each project and property. There may be a clear answer to a design issue, or more often there may be more than one answer which safeguards the integrity of the building and/or district.

3. The Design Guidelines

The City has developed design guidelines for Residential and Commercial buildings and sites, and for Signs, to help interpret the design standards in the Ordinance, and as an information and guidance resource for the community and the City.

These design guidelines apply to construction work associated with locally-designated historic landmarks sites. They also apply to work within locally-designated historic districts in Salt Lake City, including the rehabilitation of historic structures and landscapes, alterations to “noncontributing” buildings, and to new construction. They apply to single family and multi-family buildings.

The design guidelines for the treatment of historic properties and for new construction within a historic district are based on nationally accepted principles for preservation and apply to designated historic resources across the city.

At the same time, different combinations of settlement patterns and historic resources exist within each of the historic districts, and establish a context and character unique to that neighborhood. Variables that define a distinct context may include topography, street pattern, building age, landscape features, and lot size.

Residential guidelines that are tailored to the individual character of each district are included to supplement the information and guidance provided in the city-wide guidelines. Specific residential guidelines are provided for the Avenues, Capitol Hill, South Temple, Central City, and University Historic Districts. Additional residential design guidelines will be developed for each future locally designated district.

The design guidelines for commercial resources and signs address more common issues, and do not have additional guidelines for each historic district.

WHY PRESERVATION DESIGN GUIDELINES?	1
BASIC PRESERVATION THEORY	2
HISTORIC PRESERVATION PRINCIPLES	3
SELECTING A PRESERVATION APPROACH	4
HOW TO USE THE DESIGN GUIDELINES	7
FORMAT - DOCUMENT & CHAPTERS	7
FORMAT - HISTORIC DISTRICT CHAPTERS	7
FORMAT - A DESIGN GUIDELINE	8
ADDITIONAL INFORMATION	10

Why have historic preservation design guidelines?

The design guidelines provide a basis for making informed and consistent decisions about the rehabilitation and treatment of historic resources. They also serve as an informational, educational and a planning resource for property owners and their design professionals who seek to make improvements that may affect historic resources.

While the design guidelines are written so that they can be used by the layman to plan improvements, property owners are strongly encouraged to enlist the assistance of qualified design and planning professionals, including architects and preservation consultants.

The purpose of the guidelines, and the review process through which they are administered, is to explain and promote the sound preservation of the historic and architectural heritage of the city. These resources are fragile, and are consequently vulnerable to inappropriate alteration and demolition.

PART I Preservation in Salt Lake City

Pressure exists to alter or demolish historic buildings because the close-in neighborhoods where they are found are again regarded as attractive areas to live and work, and widely appreciated for their rich and unique character. These pressures are increasing as the population grows along the Wasatch Front; as residents face longer commutes, an inner-city location becomes a more attractive alternative.

Passage of the state's Economic Incentives for Historic Preservation bill in 1993, which provides income tax credits for rehabilitation work exceeding \$10,000 for properties listed on the National Register of Historic Places, has also brought new residents and investors into Salt Lake City's historic neighborhoods.

Basic Preservation Theory

The Concept of Historic Significance

What makes a property historically significant?

In general, properties must be at least 50 years old before they can be evaluated for potential historic significance, although exceptions do exist when a more recent property clearly is significant. Historic properties must have qualities that give them significance. A property may be significant for one or more of the following reasons:

- Association with events that contributed to the broad patterns of history, the lives of significant people, or the understanding of Salt Lake City's prehistory or history.
- Construction and design associated with distinctive characteristics of a building type, period, or construction method.
- An example of an architect or master craftsman or an expression of particularly high artistic values.
- Integrity of location, design, setting, materials, workmanship, feeling and association that form a district, as defined by the National Register of Historic Places Standards, administered by the National Park Service.

The Period of Significance

In most cases, a property is significant because it represents, or is associated with, a particular period in its history. Frequently, this begins with the construction of a site or building and continues through the peak of its early occupation. Building fabric and features that date from the period of significance typically contribute to the character of the site.

1 Why Preserve Historic Neighborhoods

The Concept of Integrity

In addition to being historically significant, a property also must have integrity.

To have integrity a sufficient percentage of the structure or site must date from the period of significance. The majority of the site's features or the building's structural system and materials should date from the period of significance, and its character defining features also should remain intact. These may include architectural details, such as dormers and porches, ornamental brackets and moldings and materials, as well as the overall mass and form of the building. It is these elements that allow a building or district to be identified as representing a particular point or period in the history of the city.

Historic Preservation Principles

The following preservation principles should be applied to all historic properties in Salt Lake City.

Respect the historic design character of the building.

Changing the style of the building or making it look older than it really is should be avoided. Confusing the character by mixing elements of different styles would not respect the historic design character of the building.

Seek uses that are compatible with the historic character of the building.

Building uses that are closely related to the original use are preferred. Every reasonable effort should be made to provide a compatible use that will require minimal alteration to the building and its site. An example of an appropriate adaptive use is converting a residence into a bed and breakfast establishment. This can usually be accomplished without radical alteration of the original architecture.

Note that the Historic Landmark Commission does not review uses; however, property owners should consider the impacts that some changes in use would have upon their historic properties, since this may affect design considerations that are reviewed by the Commission. In addition, the zoning code provides some incentives associated with certain uses and these may require Commission comment.

These uses **may aid in interpreting** how the building was used historically. Check the zoning code to determine which uses are allowed.

When a more radical change in use is **necessary** to preserve and keep the building in active service, then those uses that **require** the least alteration to significant elements **are** preferred.

PART I Preservation in Salt Lake City

It may be, that in order to adapt your building to the proposed new use, such radical alteration to its significant elements would be required that the entire concept might be inappropriate. Experience has shown, however, that in most cases designs can be developed that respect the historic integrity of the building while also accommodating new uses.

Note that more radical changes in use can make projects more expensive or result in the loss of significant features. Carefully evaluate the cost of alteration, as adaptation for a radical change may prove too costly, or may destroy too many significant features.

Protect and maintain significant features and stylistic elements.

Distinctive stylistic features or examples of skilled craftsmanship should be treated with sensitivity. The best preservation procedure is to maintain historic features from the outset so that intervention is not required. Protection includes the maintenance of historic material through such simple treatments as rust removal, caulking, limited paint removal and the reapplication of paint.

Preserve any existing original site features or original building materials and features.

Preserve original site features such as grading, rock walls, etc. Avoid removing or altering original materials and features. Preserve original doors, windows, porches and other architectural features.

Repair deteriorated historic features and replace only those elements that cannot be repaired.

Upgrade existing materials and elements, using recognized preservation methods whenever possible. If disassembly is necessary for repair or restoration, use methods that minimize damage to original materials and replace the original configuration.

Selecting a Preservation Approach

Each preservation project is unique.

Consequently, a 'one size fits all' set of rules and regulations will only apply in a minority of instances. It may include a variety of treatment techniques, including the repair and replacement of features, and the maintenance of those already in good condition. Some of the basic preservation treatments are described in the section that follows. In each case, it is important to develop an overall strategy for treatment that is based on an analysis of the building and its setting.

This research should begin with an investigation of the history of the property. Research may identify design alterations that have occurred, and may help in developing an understanding of the significance of the building as a whole, as well as its individual components.

This historical research should be followed with an on-site assessment of existing conditions. In this on-site inspection, identify those elements that are original, and those that have been altered. Also determine the condition of individual building components.

Finally, list the requirements for continued use of the property. Is additional space needed? Or should the work focus on preserving and maintaining the existing configuration?

By combining an understanding of the history of the house, its present condition, and the need for actions that will lead into the future, one can then develop a preservation approach. In doing so, consider the definitions of alternative approaches that follow.

1 Why Preserve Historic Neighborhoods

Adaptive Use

Converting a building to a new use, one that is different from that which its design reflects, is considered to be “adaptive use.” For example, converting a residential structure to offices is adaptive use. A good adaptive use project retains the historic character of the building while accommodating its new functions.

Maintenance

Some work involves keeping a property in good condition by repairing features as any deterioration becomes apparent, and using procedures that retain the original character and finish of these feature/s. Regular or preventive maintenance is carried out prior to any noticeable deterioration. No alteration or reconstruction is involved. Such work will avoid having to deal with future repairs and is considered “maintenance.” Residents are strongly encouraged to maintain their properties in good condition to ensure that more aggressive, and consequently more expensive, measures of rehabilitation, restoration or reconstruction will not be needed.

Preservation

The act or process of applying measures to sustain the existing form, integrity and material of a building or structure, and the existing form and vegetative cover of a site, is **defined** as “preservation.” It may include initial **stabiliza**tion work, and minor repair where necessary, as well as ongoing maintenance of the historic building materials and details. Essentially, the property is kept in its current good condition.

Rehabilitation

Rehabilitation is the process of returning a property to a state which makes a contemporary use possible, while still preserving those portions or features of the property which are significant to its historic, architectural and cultural values. Rehabilitation may include the adaptive reuse of the building, and major or minor additions may also occur. Most good preservation projects in Salt Lake City may be considered rehabilitation projects.

Renovation

To renovate means to improve by repair, to revive. In renovation, the usefulness and appearance of the building is enhanced. The basic character and significant details are respected and preserved, but some sympathetic alterations may also occur. Alterations that are made are generally reversible, should future owners wish to restore the building to its original design.

Restoration

To restore, one reproduces the appearance of a building exactly as it looked at a particular moment in time; to reproduce a pure style—either interior or exterior. This process may include the removal of later work or the replacement of missing historic features. A restoration approach is used on **missing** details or features of an historic building when the features are determined to be particularly significant to **the** character of the structure, and when the original configuration is accurately documented.

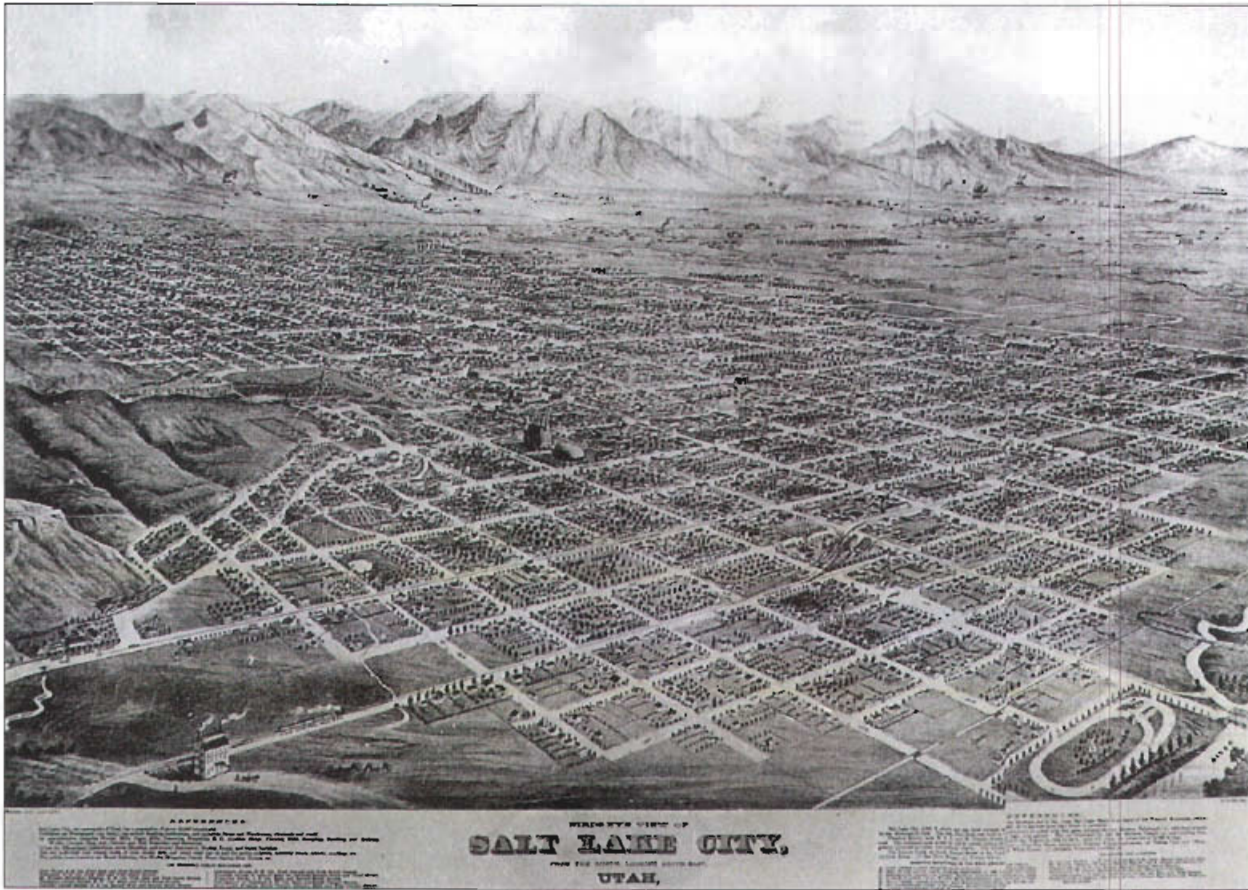

The uniform grid of the City of Zion Plan is readily apparent in this early bird's-eye view.

Remodeling

To remake or to make over the design image of a building is to remodel it. The appearance is changed by removing original detail and by adding new features that are out of character with the original. Remodeling is inappropriate for historic buildings in Salt Lake City.

Combining Preservation Strategies

Many successful rehabilitation projects that involve historic structures in Salt Lake City may include a combination of preservation, restoration, and other appropriate treatments. For example, a house may be adapted to use as a restaurant, and in the process, missing porch brackets may be replicated in order to restore the original appearance, while existing original dormers may be preserved.

How to Use the Design Guidelines

Arrangement and Format of the Document and Chapters

The Residential Design Guidelines are arranged in three sections, dealing with Rehabilitation or General Issues, New Construction and additional, specific guidelines for each Historic District.

Within the Rehabilitation section for example, the chapters address specific design characteristics of a historic building, and often include several topics within one subject and chapter. The chapters are organized in several sections, including introductory and explanatory information, the overall design objective, and the actual design guidelines; all of which form part of the design guideline review reasoning: see below. They also include supplementary resources in the form of additional reference material and suggested maintenance tips.

The guidelines are written to identify what is important and why, when considering a project in a historic district or relating to a city landmark site. They are designed to be informative, and to help with the reasoning and evaluation processes associated with both planning **and** reviewing a project for sensitivity to its context - whether that context is a building or a district.

Arrangement and Format of Historic District Chapters in the Residential Guidelines

These chapters provide additional guidance for individual residential historic districts and have a different format.

Historic Architectural Character

A general description of the district includes a summary of the history of its development, helping to explain the historic form and character unique to that historic district.

Development Trends

Future general trends in development indicating the nature of construction issues that the city typically expects to encounter in the area are summarized, and derive from a basis of recent neighborhood development experience.

The Characteristics of the District

The key characteristics of the district are summarized to inform future design considerations. This provides a context within which alterations, and particularly new construction, should be considered, with an objective of development form, scale and design that is sensitive to the immediate context and the district.

Goals for the District

The district design goals establish the long-range view for the character of the district, and provide a foundation for the design guidelines that follow, like the design objective in other chapters. In cases where the special conditions in a specific project are such that the accompanying detailed design guidelines do not appear to address the situation directly, then this statement of goals should serve as the basis for determining the appropriateness of the proposed work or direction.

The Design Guidelines

The design guidelines are arranged in several sections, which include Streetscape Features, Site and Landscape Design Features, Architectural Features and Appropriateness of Use. Design guidelines are identified in bold within each section, and each guideline may have one or more associated bullet point/s to help clarify the application of the guideline. The guidelines are also numbered to provide specific reference in the review process. The city should assess whether these guidelines and goals have been adequately met in consideration of a Certificate of Appropriateness for the proposed work.

Format of a Design Guideline

The design guideline format and structure establishes a hierarchical framework that provides general and detailed design advice, and also design options where the design guideline readily relates to the circumstances of the project, the site or building. Where the relationship is less obvious, on the other hand, and the specific guideline/s do not directly address the individual circumstances of the case, the design objective, and the context character definition discussion immediately preceding the guideline/s, provide general a direction on the design intent and appropriate solutions.

Each design guideline in the document typically will have five components.

1. Context Character Definition

This describes the elements of the character of the building and/or its setting or context that are most important to retain, if the integrity of the building or district is to be retained. This may include technical information, such as factors associated with the preservation of a historic building material, for example, as well as general preservation theory that is relevant to the topic at hand.

The guidelines and their associated context character definitions in each chapter may be divided into pertinent sub-topics. For example, in the chapter addressing Site Features, the topic "Walkways," is among those discussed. This organization allows the user to select rapidly the specific design topics within a section that are most relevant.

This discussion provides the rationale and foundation for the Design Objective.

2. Design Objective

Drawing upon existing character and /or the desired state of condition of the design element/s or context, the design objective is a statement of intent for the treatment of the design feature or characteristic under discussion. In cases in which special conditions in a specific project are such that the detailed design guideline/s that follow do not appear to address the situation directly, then the design objective provides a basis and direction for determining the appropriateness of the proposed work.

3. Design Guidelines

The design guideline is typically performance-oriented, and describes a desired design treatment. There may be one or more design guidelines for each design topic.

4. Design Guideline Application Points

Additional application points may provide expanded explanation of the guideline, suggestions on how to meet the guideline objective, or additional application points to consider. This information is listed in bullet form.

5. Design Guideline Illustrations

Illustrations are provided to clarify the intent of the guideline and are captioned accordingly to highlight particular points or examples.

Design Guideline Format - Example

Chapter 1. Site Features

1

A variety of site features are characteristic of early Salt Lake City residential neighborhoods. A house is usually appreciated in its immediate street setting. Individual sites and gardens may share common characteristics which help to define community character.

Design Objective

2

Historic site features that survive should be retained, preserved or repaired when feasible. New site features should be compatible with the historic context and the character of the neighborhood.

Masonry Retaining Walls

1

Sandstone retaining walls were often used in neighborhoods where steep slopes occurred. Many of these walls survive and often are important character-defining features for individual properties and for the districts in which they are found. Some early concrete retaining walls also exist. These should be preserved. As retaining walls frequently align along the edges of sidewalks, they help establish a sense of visual continuity in the neighborhood.



5

The low retaining wall supporting an ornate historic iron fence contributes significantly to the character of the streetscene.

3

1.6 The historic height of a retaining wall wherever possible should be maintained.

4

- Increasing the height of a wall to create a privacy screen is likely to be inappropriate.
- If a fence is needed for security, consider using a transparent wrought iron or wood picket design that is mounted on or just behind the top of the wall.
- This will preserve the wall, allow views into the yard and minimize the overall visual impact of the new fence.

Each design Guideline in the document typically will have five components.

PART I Preservation in Salt Lake City

Maintenance Tips

A 'side bar' in many chapters provides Maintenance Tips for the home owner as points or matters to consider in the regular upkeep of a building. A regular maintenance regimen will reinvest in the unique qualities of the property and keep the finishes and details in good repair, while avoiding subsequent, and more expensive, repair or replacement costs.

Additional Information

A further 'side bar' in each chapter provides a brief list of other publications and weblinks as an information resource for the owners, designers and builders. These should be of particular interest as an awareness and a 'how to' information source, providing valuable detail about a specific topic, treatment or type of project.

Additional Information

Murtagh, William J. *Keeping Time: The History and Theory of Preservation in America*. Pittstown, New Jersey: The Main Street Press, 1988.

Design Guidelines Resources - Information + Maintenance Tips - Example

Chapter 5. Porches



Enclosing a front porch will significantly compromise the architectural integrity of the house.

5.4 The open character and integrity of a historic front porch should be retained.

- Enclosing a porch should be avoided.
- Restore a previously enclosed porch to its original open character whenever feasible.

Additional Information

Additional Information

Massey, James C. and Shirley Maxwell. "Reading the Old House" and "Sleeping Porches." *Old House Journal*, July/August 1995.

Maintenance Tips

Maintenance Tips for Porches

- Maintain drainage off of the main roof of the house, as well as off of the roof of the porch.
- Channel water away from the foundation of the porch.
- Maintain a good coat of paint on all exposed surfaces.

Historic Context and Architectural Styles



Contents

Introduction	3
Historic Overview of Salt Lake City	4
Classical	7
Picturesque	8
Gothic Revival	9
Italianate	10
Second Empire	11
Victorian Era	12
Victorian Eclectic	14
Queen Anne	15
Shingle	16
Period Revival	17
Spanish Colonial Revival	18
Tudor Revival	19
Colonial Revival	20
Dutch Colonial Revival	20
Georgian Revival	21
Neo-Classical Revival	21
Foursquare	22
The Bungalow	24
Modern	29
International	29
Art Moderne	30
Post-War	31
Post-War Cottage	31
Ranch	32
Multi-family Structures	33
Commercial Structures	36

Cover Page Image:

This house, located at 1172 East 100 South, was constructed in 1894 for William A. Neldon, a prominent businessman and civic leader. It was designed by Frederic Albert Hale, who was also the architect of the Alta Club and the Keith-Brown mansion on South Temple.

Introduction

Salt Lake City contains a multitude of architectural styles. This rich architectural heritage enhances the city, establishes its identity and provides a strong “sense of place.” It also provides clues about the evolution of Salt Lake City, in terms of the sequence of development in different neighborhoods.

This chapter provides a brief overview of various historic styles found in Salt Lake City. While this section makes reference to a wide range of styles found here, it is not exhaustive. Certain architectural styles may exist that are not included in this section.

Property owners should review these descriptions carefully. In many cases the design guidelines that follow make reference to the characteristics of styles that are presented in this chapter. In some cases, specific design guidance is included in the style description, depending on the prevalence of the style being described. For example, the section on Bungalows provides special guidance because the bungalow is a prevalent building type in many historic districts in Salt Lake City. The homeowner is encouraged to use the styles section in analyzing the overall historic character of his/her building, as well as distinguishing its character-defining features. Ultimately, this should aid the homeowner in choosing an appropriate design solution for any proposed work.

Historic Overview of Salt Lake City

The story of Salt Lake City's architectural past begins with its physical layout, which loosely conformed to Joseph Smith's Plat of the City of Zion. Salt Lake City was divided into blocks of 10 acres, with a block in the center reserved for the temple and wide streets of 132 feet. The blocks were divided into 8 lots of 1.25 acres each, enough to accommodate a family and the agricultural needs of everyday living, such as a vegetable garden, fruit trees and a few livestock and chickens. Residents travelled beyond the city wall at 900 South to farm the land that leaders of the Church of Jesus Christ of Latter Day Saints had assigned to them; resources such as timber and water were communally owned. This system was designed to establish an efficient use of land and prevent social isolation. Although the blocks were later subdivided into smaller parcels and any semblance to its early appearance as an agrarian village has long disappeared, Salt Lake City's orderly pattern and wide streets identify a planned community from its inception.

As in any new settlement isolated from an industrial society, the settlers were driven by expediency and thrift when it came to providing permanent shelter. Dwellings were simple: ornamentation was sparse, and floor plans consisted of a "double pen," "hall parlor," or a "central hall" arrangement. Their symmetry, balance, and simplicity displayed at a very basic level the classicism associated with the Greek Revival style.

Adobe, rather than wood, was the predominant material in the Salt Lake valley from 1847 until fired bricks became available in the 1860s. We tend to forget this because so few adobe structures from this period have survived and because log cabins are so lovingly presented in public places. None other than Brigham Young, however, admonished against the use of logs, stating that "log buildings do not make a sightly city." While adobe had the disadvantage that it could not withstand poor weather and did not lend itself to complicated construction, it was cheap, if not free, and didn't require skilled labor. It was used not only for homes, but also for outbuildings, such as barns and sheds, and also for public buildings, such as Social Hall.

While the initial village layout prevailed, both physically and socially, throughout the 1860s, the city began to push beyond its original boundaries. The establishment of Fort Douglas in 1862, the activity of the Red Butte quarry, and the moving of the slaughter yards in 1860 to the mouth of Dry Canyon, drew residents eastward. Residents also began to consider moving to the lower slopes of the Avenues and Capitol Hill to escape the noise and confusion of Main Street and South Temple; they had become busy thorough-fares, as merchants travelled between the fort and downtown. Gradually people began to use fired brick instead of adobe.

The biggest factor that affected architecture, however, was the completion of the trans-continental railroad in 1869, so that the built domain began to reflect Salt Lake City's new link to the outside world. Now residents had access to the building guides, pattern books and home magazines used nationally, as well as the necessary materials to construct the homes promoted in the literature.

The railroad was the first, important step that enabled Salt Lake residents to keep pace with the architectural mainstream. Access to national markets made for a more complex economy, one based on cash, rather than trade, and based on capitalism, instead of subsistence. Most notably for the territory, it opened up the mining industry. In response to this economic development, Salt Lake City became more urban within a decade. A variety of styles, such as the Second Empire, Italianate, and Gothic Revival and the Queen Anne were used; builders quickly produced the complicated floor plans, asymmetrical facades and mass-produced ornamentation that were used in the late Victorian era.

The growth of the city led to municipal improvements such as better water distribution, the installation of gas lamps and electric street lights and a mass transportation system using electric railway cars. This last development enabled people to live increasingly farther from where they worked and resulted in the development of “streetcar suburbs,” especially in the area southeast of Liberty Park. Class differences emerged and characterized many neighborhoods. In general, working class residents lived in Central City and west of the railroad tracks. Professional, middle class people chose the Avenues and outlying suburbs in which to build or purchase homes — more expensive real estate because it was quieter and located on the benches, out of the smog. By the end of the 1880s, Salt Lake City had made the transition from a theocratic utopia to a regional center, one that looked like many other communities west of the Mississippi.

Also by this time, Salt Lake City was home to several millionaires who had made great fortunes in mining and other industrial pursuits. They built imposing residences, usually in classical styles such as Renaissance, Classical and Georgian revival. Although several still stand in Central City, Capitol Hill, and the Avenues, the most lavish were located on South Temple. Salt Lake’s prosperity attracted architects such as Richard Kletting, Frederick Ware, and Frederick Albert Hale. Their professional training and experience coupled with their clients’ means led to a new, more sophisticated approach to architecture. During the period from about 1895 to 1915 these architects and others designed structures to house the new state’s institutions, such as the State Capitol, the public Library (later the planetarium and now O.C. Tanner) and the University of Utah in its current location, as well as clubs such as the Alta and University clubs (the latter demolished in the 1960s) in which people could separate themselves socially from the rest of society. The Salt Lake Temple was completed in 1893; the construction of the Cathedral of the Madeleine and the First Presbyterian Church announced that other faiths had a permanent stake in the city.

Historic Context and Architectural Styles

Concurrently, a steady influx of new residents provided a healthy market for residential development at the lower end. This occurred both at corporate and individual levels. James Anderson founded the Anderson Realty Investment Corporation in 1892 and constructed many Victorian Eclectic houses, several of which can be seen along 300 South between 600 and 700 East. These were substantial, two story structures with a boxy shape that Anderson could build for about \$3,200 and sell quickly at almost twice the price. Occasionally widows would subdivide their property and build two or three houses next door in order to get a monthly income and make a capital investment. Such homes — either of professional developers or individuals — adhered to no particular style and were designed according to the whim of the owner. They might be a bungalow, a Foursquare or “box” type or display a Victorian influence

About 1900, developers began to invest in large apartment buildings. This was a new building type for Salt Lake City — one that created a more urban landscape and indicated a substantial shift in demographics. They attracted a variety of residents: the wealthy who didn’t want the trouble of owning a house; the widowed who didn’t need the space of a house, and people just starting out, who couldn’t afford a house. W.C.A. Vissing constructed several buildings for the Covey Investment Company and was the city’s most prolific apartment builder. Elegant apartment buildings, such as the Maryland, were constructed on South Temple, while others, less prestigious but still comfortable, were located east and north of downtown and in the Avenues.

Bungalows and Period Revival cottages dominated the residential building scene from the end of World War I through the 1920s but with the onset of the Great Depression, the construction industry ground to a halt. The few people who could afford to build a new home generally picked traditional designs, such as the Cape Cod cottage or a revival style, such as Dutch Colonial. In rare instances the International or Art Moderne styles were used.

After World War II birth rates soared. Construction boomed and new subdivisions were developed. Unprecedented numbers of people could afford cars and the many new consumer goods that flooded the market. With the rise of the automobile, the popularity of the new suburb, and the encroachment of commercial development east of downtown, many of Salt Lake’s older neighborhoods began to decline. But as usual, this trend reversed. People grew weary of commuting and were disturbed by the demolition of irreplaceable landmarks. A preservation ethic emerged and slowly people began to take a second look at the city’s old buildings. They painstakingly restored historic homes and in the process, revitalized neighborhoods. Today, these neighborhoods are Salt Lake City’s most desirable real estate. Much has been lost but even more has been saved.

Classical

c. 1851-1885

Although long out of fashion in the eastern half of the United States, variants of the classical styles, Georgian, Federal and particularly Greek Revival, continued to be popular in Utah into the 1880s. They were familiar styles to pioneers arriving from New England, upstate New York and the Midwest. These styles are characterized by their symmetry and the use of classical features: a wide frieze or fascia at the cornice, pediments over the windows or doors and round columns on porches. The homes from this period are generally side-gabled, so that when viewed from the side they resemble small temples. Alternatively they sometimes have one-story, shed-roof additions at the rear for a "salt-box" profile.

Characteristics

- usually side-gabled massing, one or two rooms deep
- one or two stories
- symmetrical facade, with the entrance in the middle
- stone foundations
- smooth plaster walls or clapboard siding
- two-over-two or one-over-one, double-hung windows
- wood cornices and fascia
- stone, projecting window sills
- low-pitch roof with cornice returns
- divided transoms over the doorways
- one-story, shed-roof addition at rear



Classical Porch, at central entry.



This is an unusual example of a front facing Greek Revival style building in the Capitol Hill Historic District. Despite the rarity of its orientation, its massing, stucco finish, pronounced wood cornices and fascia are clearly in keeping with this style and period.

Historic Context and Architectural Styles - Picturesque



Gothic Revival

Picturesque

c. 1865-1885

Nationally, Picturesque styles — especially the Gothic Revival and the Italianate — represented in part a rejection of the Greek Revival, which was seen as being too discordant with the landscape and not easy to remodel, especially for additions. During the 1830s, a group of influential reformers called for a house style that would reinforce righteous living, that would help shore up Americans in the face of social upheaval caused by westward expansion and industrialization. Reformers wrote about residential architecture in terms of morality, and different styles were described as dishonest or honest. Locally, residents might have been aware of the theory behind the promotion of these styles, but it is more likely they represented something fashionable, that was newly available. The use of the Picturesque styles pushed Salt Lake citizens a little closer to the American mainstream, after enduring two decades of isolation.

Gothic Revival

c. 1865-1880

According to *Utah's Historic Architecture, 1847-1940*, the Gothic Revival style was most popular in Utah during the 1870s, and in a broader context, was part of the Romantic movement that valued emotion over rational thought. As a rejection of classicism the most vocal proponent of this style, Andrew Jackson Downing, emphasized vertical lines, deep colors and the use of applied ornament. Few such homes exist in Salt Lake's historic districts but, because this style is so unique in this area, they greatly contribute to the architectural texture and richness of the city. Three can be found along Quince Street in the Capitol Hill Historic District; another, built in 1860, is located on B Street in the Avenues Historic District.

Characteristics

- steeply pitched roof
- cross gable roof plan, or
- side gable roof plan with central cross gable over the door
- clapboard or plaster siding
- quoins
- decorative barge board along eaves of main gables and dormers
- two-over-two, double-hung sash windows
- pediments over windows
- bay windows
- lancet windows
- elaborate porch railings: turned posts, cut-out boards



Gothic Revival



Historic Context and Architectural Styles - Picturesque

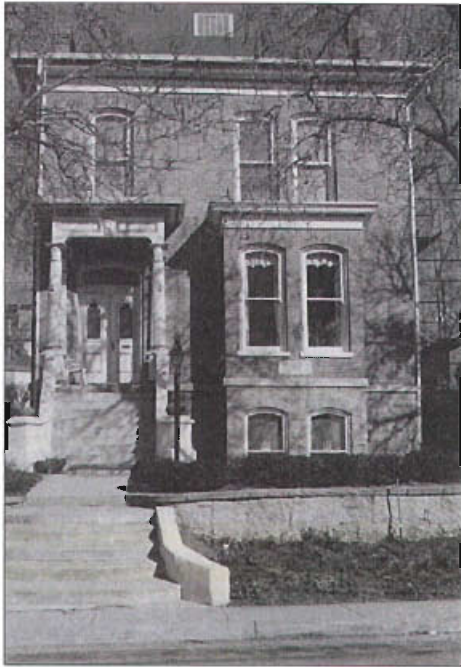

Italianate

Italianate

c. 1870-95

The Italianate style was introduced by Andrew Jackson Downing in his 1850 publication, *The Architecture of Country Houses*. He extolled the virtues of the Gothic Revival, but offered the “villa,” a version based on Italian country houses that veered more toward classicism and did not have the religious overtones of the Gothic Revival. The style was used in Salt Lake after 1870, but it was not widely used and few examples remain.

Characteristics

- brick, wood clapboard, stucco
- double-hung, narrow windows, often with round arch heads
- window panes are either one-over-one or two-over-two
- protruding sills
- ornate treatment of the eaves, including the use of brackets, modillions and dentil courses
- low-pitched, hipped roof
- blocky, cube shape, with a side-passage plan, or cross-gable
- bay windows, often rectangular in shape
- quoins
- cresting
- transom, often curved, above the front door
- ornate porch treatment, with round columns or square posts, and bargeboard ornament

Second Empire

c. 1870-1890

The Second Empire refers to the French reign of Louis Napoleon, the grand-nephew of Napoleon Bonaparte, who ruled from 1852 to 1870. In both France and America, the Second Empire style coincided with a period of prosperity and materialism, and was associated with urbanity and cosmopolitan society. In many cities in the United States it was used for government structures, but it was popular for residences as well. Classical details, such as quoins, round columns and heavy friezes were often used; however, there was usually so much going on that Second Empire buildings, at least high-style examples, took on a life of their own. Extant Second Empire houses in Salt Lake were constructed of brick and wood, and thus do not have the rich, sculptural wall texture found in examples in other parts of the country. Instead, builders and architects achieved the exuberance of this style by using asymmetrical and complicated massing, and by applying plenty of ornament: cresting, railings, and moldings.



Second Empire

Characteristics

- steeply pitched, mansard roof
- roof can be either straight or concave, and is interrupted by dormers
- complex massing forms
- brick, stucco or wood clapboard
- wrought-iron ornament, such as cresting on roof or heavy, ornate iron fencing
- wide eaves, often with modillions
- corbelled chimney
- dormers with heavy moldings
- double-hung windows, either one-over-one or two-over-two lights
- hood moldings over the windows
- sandstone foundation, porch steps

Historic Context and Architectural Styles - Victorian Era

Victorian Era

c. 1870-1910

Technically the word “Victorian” refers to the long reign of Queen Victoria, which lasted from 1833 to 1901 and encompassed the rich variety of architectural styles that were popular during the nineteenth century. Architecturally the word “Victorian” evokes the complexity and irregularity seen in the massing and materials of modest homes to large mansions. The use of Victorian era styles in Salt Lake City became available with the advent of rail transportation; access to national markets and culture was reflected in its architecture.

Three specific styles popular during this period are discussed below; other examples, such as the Richardsonian Romanesque, Eastlake and Stick style can be found in Salt Lake’s historic districts but not in great quantity. (For more information about these styles, refer to Utah’s Historic Architecture or A Field Guide to American Houses.) The majority of Salt Lake’s “Victorian” houses do not represent pure examples of anything; simply describing a house built in Salt Lake after 1880 as “Victorian” can be misleading because residents and builders tended to take elements from one style and mix it with another. Still, among most Salt Lake residents the term conjures up the image of a house built about 1890, either one or two story, with an asymmetrical form, a steeply-pitched roof and “lots of gingerbread.” No matter if the house is Queen Anne, Shingle, “eclectic” or “transitional,” if it can truly be termed “Victorian” it will have several of the following characteristics:

Complex Massing

The massing of Victorian era homes is often a profusion of towers, turrets, dormers, gables, bay windows and porches. Even small homes look complicated through the use of a cross-wing floor plan and roofs with a variety of planes and slopes.

Surface Ornamentation and Materials

Because fired brick was the most commonly used building material from 1865 on, Victorian era homes in Salt Lake do not display the abundance of wall decoration as those in cities where wood construction predominated. Still, Salt Lake Victorian era structures display a variety of materials.

- Shingles are the most commonly used embellishment on Victorian era homes in Salt Lake, especially in gable ends and dormer walls.
- Horizontal wood siding, although also used during other periods, can be seen on Victorian era homes. The siding has a crispness that gives the building a repetition of light and shadow that is texturally rich.



Decorative shingles, window trim and porch detail of the Victorian era.

Historic Context and Architectural Styles - Victorian Era

- Fancy scroll cut wood work, especially around gables and porches.
- Ornamental brick work, such as corbelling and rows of soldier bricks as lintels.
- Use of wrought or cast iron as cresting along ridge lines or as railings and fencing. The metal was heavy, in a complicated pattern, and is generally found in more prestigious structures and sites. In contrast the "licorice stick" porch supports and railing that became popular in the 1950s had a negative effect on historic character.
- Use of stone for foundations (sandstone, in a variety of colors and qualities, is the most common).
- Combinations of materials. For example, horizontal siding can be seen on the first story and shingles are used on the second. A very common combination is the use of sandstone for the foundation, the use of fired brick on the walls, and wooden shingles in the gable ends



Victorian Eclectic



Classical details combined with Victorian Eclectic massing.

Windows

- The standard window in a Victorian era house is the double-hung sash, made of wood.
- A large, plate-glass window with a fixed transom, often with leaded or stained glass, is commonly used in the front of the house. These are sometimes flanked by narrower windows that are usually in a one-over-one configuration.
- Palladian and oval windows are frequently used in the gable ends.
- Windows are often grouped in thirds (tripartite) in varying combinations.



Historic Context and Architectural Styles - Victorian Era



Plate glass window with leaded glass transom.



Palladian window



Victorian Eclectic

Victorian Eclectic

c. 1885-1910

As Thomas Carter and Peter Goss point out in *Utah's Historic Architecture, 1847-1940*, "Victorian Eclectic is less a distinct style than an amalgamation of elements from many popular nineteenth century styles." It often has a massing defined by the Utah State Historic Preservation Office as a "central block with projecting wings"--a central cube with a hipped roof from which a shallow gabled wing projects. Thousands of examples of the one-story form can be seen throughout Utah, but many two-story examples can be found as well.

Characteristics

- hipped roof over the main block; projecting wing with front-facing gable
- porch with shed roof on one-story; often a gable on two-story examples
- usually round columns
- tripartite, often Palladian window in upper story of gable
- tripartite division of windows on projecting wing

Queen Anne

c. 1885-1905

Proponents of the Queen Anne style found their inspiration from the medieval art and architecture that preceded its namesake's reign (1702-1714), growing out of recognition of vernacular, modest, pre-industrial structures, and a desire to bring about a close relationship of architecture and ornament.

In the United States, it developed from a desire to identify a national style. Both the Centennial Exposition, held in Philadelphia in 1876, and the popularity of New England coastal towns, exposed Americans to their colonial, vernacular architectural past. The wood clapboard and shingle houses that were constructed in eastern Massachusetts during the seventeenth and early eighteenth centuries brought about the usual longing of security and simplicity that earlier ages always evoke, and were all the more appealing because they were seen as pure "American." The new Queen Anne style used the broad gables, long sloping roofs and small pane windows of these early houses for the exterior, while giant hearths inglenooks and spacious, inviting halls influenced interior design. The style introduced a new kind of open planning and a new way of massing volumes of space; it was inherently eclectic and became available to homeowners of all income levels.



Queen Anne with turret.

Characteristics

- irregular, asymmetrical massing
- use of bay windows, towers, turrets, dormers, gables — anything that protrudes from the wall and the roof
- use of varying wall textures
- use of ornament; wooden scroll work on porches and gables, complicated brick patterns, ornate metal railings
- windows with leaded or stained glass
- windows with large panes of glass surrounded by small panes
- tall brick chimneys



Shingle Style

Shingle

c. 1885-1900

The Shingle style is closely related to the Queen Anne and the Colonial Revival styles, in the use of asymmetrical massing, broad front porches and window treatments. Its defining characteristic is the extensive use of shingles. The Shingle style can be seen on high-style, architect-designed homes; it was not used for housing those of lower incomes.

Characteristics

- structure is almost entirely clad with shingles
- secondary materials include sandstone foundations and wood for windows and trim
- large, dominant front gable
- asymmetrical massing, including the use of towers, dormers and eyebrow windows
- the porch is a prominent feature that is tucked under the main roof line
- use of classical features, such as round columns on porches, one-over-one double-hung sash windows, and Palladian windows

Period Revival

c. 1890-1940

Period Revival styles encompass the reworked versions of the Spanish Colonial, the English Tudor, French Norman, and classically-inspired architecture, along with many other variants used throughout the country's colonial history. With the exception of the Neoclassical, which was generally reserved for mansions, period revival styles lent themselves well to designs for modest homes, and offered an alternative to the bungalow. Developers and builders found that evoking a cozy image of the past sold well, and that revival styles satisfied the need of home buyers to conform to tradition, while making use of contemporary convenience and floor plans, such as the L-shaped living room. Several neighborhoods in Salt Lake were constructed with rows of period revival "cottages" - such as the area near the 1500 South and 1500 East intersection - in the same way that scores of bungalows were used in subdivisions surrounding Liberty Park. However, many Period Revival styles, especially the Spanish Colonial and the English Tudor, are less common in the city's local historic districts because the development of these areas occurred prior to the popularity of these styles. Still, Period Revival homes add interest to the streetscape and contribute to the eclectic character of the districts.



Spanish Colonial Revival

Spanish Colonial Revival

c. 1915-1935

This style was popularized by the Panama-California Exposition, held in San Diego in 1915. The exposition was widely publicized, and the use of architectural examples from the Spanish Colonies encouraged Americans to realize that their country had a rich Spanish heritage, as well as an Anglo-Saxon past. Several modest and high-style examples of this style exist in the historic districts.

Characteristics

- use of stucco, often with a textured pattern
- use of tile roofs, usually red
- use of wrought-iron for balcony and porch railings
- decorative wall surfaces, using tile or low-relief terra cotta sculpture
- round-arched opening

Tudor Revival

(c. 1915-1935)

As with many styles, the Tudor Revival does not adhere to the source of its inspiration, that of sixteenth-century English architecture, but instead is a mixture of elements from an American image of medieval forms that resulted in something “quaint.” The development of the Tudor Revival style was associated with the Arts and Crafts movement, in which medieval architecture and crafts were valued as a rejection of the industrialized age. Ironically, the popularity of the style was in large part owing to its exposure through mail-order catalogues such as Sears Roebuck and the Aladdin Company, in which all of the parts of the house were pre-assembled and shipped by rail anywhere in the United States. The style was used extensively during the 1920s and 1930s; it was used both in large, formal examples (particularly in the University Historic District) and for smaller, modest homes.



Tudor Revival

Characteristics

- steeply pitched roof
- cross-gabled roof lines
- decorative half-timbering
- decorative masonry
- arched doorways
- casement windows, often with leaded, diamond panes
- projecting entryway that follows slope of front gable
- rolled edges on roofing (an attempt to imitate thatch)
- use of stucco or brick

Historic Context and Architectural Styles - Period Revival



Colonial Revival



Dutch Colonial Revival

Colonial Revival

c. 1890-1940

“Colonial Revival” encompasses many variants of residential architecture used from about the turn of the century through the 1930s, and was especially popular during the teens. It can apply to a Georgian Revival mansion, a Neoclassical home, a Dutch Colonial house or a structure in which elements of several of these styles were used. Massing forms vary but they often have classical details, such as dentil moldings, pediments over the doorways, round columns and lunette windows.

Dutch Colonial Revival

c. 1890-1915

The “Dutch Colonial Revival,” style has a gambrel roof form. This style is closely allied with the Shingle and the Queen Anne styles. The details, such as the window pattern, porches and materials are very similar.

- gambrel roof - both side-and front-facing variations can be found.
- shingle gable end
- two story
- prominent front porch, with classically-detailed porch supports and plain balustrades
- double-hung sash windows, with either single panes or multiple panes in the upper light.
- lunette windows in the upper gable.
- large, single pane windows with a fixed transom on the first story

Georgian Revival

c. 1895-1930

- usually large, elaborate
- brick (often red) or wood clapboard
- ornate moldings, such as dentils and modillions
- round columns with complex capitals
- hipped roofs with shallow pitches
- dormers
- double-hung windows, either one-over-one, six-over-one or six-over-six
- low porch railings with turned balusters
- prominent center window on second story, often arched or curved
- quoins
- shutters



Georgian Revival



Neo-Classical

Neo-Classical Revival

c. 1895-1925

- full-height porch with a pediment, round columns with complex capitals. In some instances the porches are curved porticoes
- hipped roofs
- eaves with dentils, modillions, prominent frieze
- shutters
- panelled doors surrounded by pilasters and a pediment
- double-hung windows; usually one-over-one, but sometimes six-over-six or six-over-one
- low porch rails with turned balusters

Historic Context and Architectural Styles - Foursquare



The Foursquare

The “Foursquare,” also known as “the Box”

c. 1895-1915

The Foursquare, also known as “the box,” is really more of a type or a form than a style, and architectural historians differ as to its origins. Some say that it is a descendent of the classical styles that were popular in the United States during the late 17th and 18th centuries because of their blocky shape and hipped roofs. These early houses, however, were wide and two rooms deep and not suitable for urban lots one hundred years later. The Foursquare was thus devised to adapt to narrow parcels of land. Other historians claim that it is merely a transition between the Victorian era and the bungalow — lacking the fussiness of the former but not achieving the cozy, earth-hugging quality of the latter. Mail order catalogs disseminated the style from 1900 to the 1930s. throughout the country. Salt Lake City has numerous examples, and this style is especially prevalent in the Avenues, and in the blocks east of 1000 East on South Temple.

Historic Context and Architectural Styles - Foursquare

Characteristics

- looks like a box
- low-pitched hipped roof
- one-over-one, double-hung windows, or
- one-light, fixed window; with fixed transom
- prominent lintels and sills
- full, open porch
- wide eaves
- brackets in some instances
- dormers: shed roof, hipped (with a low pitch), gabled (sometimes with a pediment)
- outside siding: wood clapboard, stucco, brick. Dormer walls shingled in Craftsman examples.
- rare examples have quoins
- concrete or brick foundation
- rear, frame, shed roof addition (or secondary space) at rear
- if classical or Colonial Revival: vertical rail balustrade on porch, round porch columns with Doric capitals that are sometimes doubled and a broad fascia that is an entablature
- if Craftsman, porch has square posts, tapered arched openings, brick pony walls



Because of its simplicity, the Foursquare lends itself to many styles. With thick square posts and exposed rafters it takes on a Craftsman tone. With rounded porch columns and a pediment on the porch roof it becomes classical.

The Bungalow

c. 1905-1925

Like the term “Foursquare,” the word “bungalow” denotes a type rather than a style. It is believed that the word comes from a type of East Indian dwelling with broad verandas. Its immense popularity in the United States springs from a rejection of the constraints of the Victorian era, from the Arts and Crafts movement, and from the fact that it lent itself well to both modest and impressive house designs.

Although bungalows display a variety of materials and details, they are easily recognized by their wide, low-pitched roofs and broad front porches that create a deep, recessed space. Many bungalows fall readily into the Arts and Crafts categories, with exposed brackets and rafters, the use of “art” glass in windows and the combination of different textures, such as cobblestone and shingles. Others represent scaled-down Prairie-style versions, with low-pitched roofs, broad eaves and simple geometric shapes that provide an overall horizontal appearance.

Thousands of the second type were built in new subdivisions in Salt Lake City about 1910. These are especially prevalent east, west and south of Liberty Park and, although many examples can be found in the city’s historic district, the districts are old enough that by the time the bungalow appeared there was not enough undeveloped land to build rows and rows of them. Still, in all the historic districts they represent an important era in the city’s architectural development, continuing to evoke their original intent: comfortable, informal living.

Characteristics

- a rectangular plan with one or two stories
- different roof types: a steeply pitched roof with the ridge line parallel to the street that covers a porch extending the full width of the house and hip-roofs with a shallow pitch
- exposed rafters, brackets — anything to evoke the structural composition of the building
- brick, wood shingle or clapboard siding
- broad eaves
- thick, tapered porch posts
- rectangular bay windows
- casement windows
- large, plate glass windows
- wing walls from the porch
- dormers that follow the line of the roof
- use of cobblestone
- concrete cap around porch wall
- both sandstone and concrete foundations were historically used on bungalows. Concrete foundations generally extend one to two inches beyond the wall.

Historic Context and Architectural Styles - The Bungalow



Bungalow with projecting porch.



Bungalow with inset porch.

Wall Materials

- Many materials were historically used on bungalows.
- Arts and Crafts bungalows often had wooden shingles or shakes, cobblestone and brick.
- Prairie-style bungalows are usually brick, and sometimes have a brick wainscoting with stucco above.
- Although a variety of materials were often used on the same house, too many materials can ruin the simplicity that is an inherent characteristic of the bungalow. Shingles, for example, would be inappropriate on Prairie-style bungalow.

Windows

Many different window types are appropriate for bungalows. Solutions will depend on what style the bungalow is and where the window is located on the house.

Arts and Crafts

These windows are generally more complex than those of the Prairie style.

- Tripartite (divided into thirds) arrangements: two long windows flanking a wider central window which has a transom; windows of an even size, either aligned vertically or horizontally.
- Small paned windows. These are frequently seen in attic windows, in transoms and in the upper sashes of single hung windows.
- Casement. Probably not as prevalent in Arts and Crafts, but still appropriate.

Historic Context and Architectural Styles - The Bungalow

Prairie

- Large, plate glass windows are appropriate for this style.
- Casement windows are a hallmark of this style, and are appropriate. Single or double-hung windows can also be used.
- Long, wide concrete lintels and sills are frequently seen on this style; these features should be retained.



Prairie-style bungalow

Doors

The doors of bungalows often imitate the geometric qualities found with this house type.

- Historically the doors are wooden with panels and windows in the upper third.
- Sidelights were occasionally used, but are not a common feature. If they exist, they should be retained.
- Doors with Victorian era elements, such as ovals or frosted glass, are not in keeping with the bungalow style.
- Heavy, elaborate storm doors should not be used.



Porch columns with Arts and Crafts details, rafter tails.



Bungalow with Arts and Crafts details.

Historic Context and Architectural Styles - The Bungalow



Arts and Crafts style bungalow with rock porch piers.

Porches

- Along with the wide eaves and the broad roof form, the wide, prominent porch is the most important feature of the bungalow, and should be maintained.
- A variety of posts is appropriate. Shapes can be tapered, square or round columns. Materials can be brick; brick to the rail level with wood above; stucco; wood; and for Arts and Crafts bungalows, cobblestone and shingles. Again, it is a good idea not to mix too many materials.
- Railings also took on different designs. Balusters can be wooden 2 by 2's, spaced about 2 inches apart. They can be flat with a "cut-out" shape. The wall around the porch could also be brick, particularly appropriate for Prairie-style bungalows; or if the house is shingled, the porch wall might also be shingled. In a few instances, a heavy, curved wrought-iron was used.

Modern

The modern styles discussed below derive their origin from a variety of sources, but overall the impetus to the “modern” styles was generated by a rejection of all historical references. Proponents of modernity did not differ from reformers of other eras in their desire to use design to address social issues, but they distinguished themselves by shunning the past as well as cultural or national contexts. Additionally, modern architects stressed the emphasis on volume and the inherent value and elegance of materials. Architects had new structural options, primarily the steel frame and reinforced concrete, so that flat roofs, greater window space and cantilevered elements could be used. They embraced new technology and “the machine age,” and their imprint has had a profound effect on American architecture and urbanism.



International Style

International

c. 1930-1940

The use of the words “international style” refers to the title of the exhibit promoted by the Museum of Modern Art in New York City in 1931 presenting the work of forty architects from fifteen countries. It has become synonymous with modern styles and post-World War II architecture.

Characteristics

- flat roofs
- an emphasis on volume, rather than mass, most often expressed through an extensive use of glass and angular, horizontal shapes
- asymmetrical facades
- corner windows
- metal casement windows, often multi-paned
- metal pipes used for balusters
- no surface ornamentation
- an attempt to create smooth wall surfaces, although brick, as the predominant Utah material, was often used

Historic Context and Architectural Styles - Modern



Art Moderne

Art Moderne

c. 1930-1940

Often closely related to the International Style in appearance, the Art Moderne was devised as a way of incorporating the machine aesthetic into architecture, in the sense that buildings could emulate motion and efficiency. It is also referred to as the Streamlined Moderne, and always carried the aura of the futuristic. Whatever the term, in this case architecture followed industrial design, as “the slick look” was used for everything from irons to baby carriages.

Characteristics

- an asymmetrical facade, with a combination of rounded corners and angular shapes
- use of glass block
- use of metal sash windows with small panes, often placed at corners
- horizontal bands at the cornice, referred to as “speed bands”
- references to ocean lines, as in the use of “porthole” windows and metal railings

Post-War

Post-War Cottage

c. 1930-1950

The Post-War Cottage (sometimes referred to as a "Cape Cod cottage" or a "World War II-Era cottage") is often considered as a sub-category of the Colonial Revival. They mark a transition between the Colonial Revival examples constructed before the war and the ubiquitous ranch type homes built afterwards. Because of their relatively recent construction many people have a difficult time thinking of them as "historic," but in most instances they have met the fifty-year mark establishing significance, and their distinctive characteristics (listed below) make these buildings worthy of a sensitive and appropriate preservation approach.

- brick, shingles or wood clapboard
- panelled door, surrounded by pilasters and an entablature
- small entrance porch with round columns with a simple capital
- double-hung windows, often with six-over-six lights
- alternatively multi-pane metal sash windows
- shutters dormers on front roof slope



Cape-Cod Cottage



Detail on a Post-War Cottage



Ranch Style House

Ranch

c. 1946-1970

The ranch style, with its roomy interior and “easy living” connotation, appealed to the post-World War II generation. Because of the Depression and the war, Americans had been deprived of consumer goods for fifteen years. During this period the home-building industry was at a standstill, but after 1945, the pent-up demand, coupled with the provisions of the G.I. Bill, led to an explosion of single-family home construction. Sometimes referred to as a “rambler,” ranch style homes were built in great quantities. Not many can be seen in the city’s historic districts because the style achieved popularity after their development; instead, they were built as infill housing.

Characteristics

- flat or slightly pitched roof
- prominent, built-in garages
- one story
- decorative iron or wooden porch supports
- asymmetrical massing and forms
- metal or wood window frames
- use of flagstone for decorative purposes, such as planter boxes

Multi-Family Structures

The construction of apartment buildings at the turn of the century represented one indication of the urbanization of Salt Lake City. An article in the Salt Lake Tribune in 1902 stated:

"It is generally recognized by farseeing investors that the period of cottages in Salt Lake has reached its highest point and the period of flat buildings, marking another stage in the evolution from town to city, has just begun." (July 27, 1902, p. 32).

During the period from 1902 to 1931, at least 180 apartment buildings were constructed in the central city (including the Avenues) sections of Salt Lake. They did not house the inner city poor; rather their occupants included members of the middle-class who were at a transient period of their lives: unmarried young adults, widows, childless couples, retired workers and people starting new careers.

All of the apartment buildings had fired brick exteriors and were usually at least three stories tall. Prior to World War I, "walk-up" apartments were the norm. They contained six to eight units (three or four stories) with two units off of a central hallway. They almost always have projecting porches on the front and frame utility porches with back stairways at the rear.

After World War I the "double-loaded corridor" type replaced the walk-up. These have a narrow end facing the street and are long, rectangular blocks. They are usually between three and five stories tall. There are several units on each floor that flank a long corridor. These apartments were well-suited to the large, deep blocks in Salt Lake

Other variants exist, but are not as numerous. These include the "U," the "H," and the hotel block (similar to the "U" but with a commercial use on the first story)."



The Kensington Apartements were constructed about 1905, and represent a type of apartement known as a "walk-up."

Historic Context and Architectural Styles - Multi Family



A double-loaded corridor apartment building.

Walk-up

- brick exterior walls
- flat roof
- front porch bay that extends the full height of the building
- frame, often enclosed, porch at the rear
- high, raised basements, often stone but also concrete
- defined front and back facades

Double-Loaded Corridor

- brick exterior walls
- flat roof
- if balconies exist, they are purely ornamental, very shallow, often with wrought iron railings
- bay windows or French doors on the street facade
- the "front" of the apartment, from the perspective of the tenant, is the corridor, and the exterior side walls form the "back."

Both types exhibit a variety of styles, most commonly Classical or Colonial Revival. Walk-ups are generally classical.

Classical Revival

- Appearance of a parapet because of an applied, projecting cornice, usually about one foot from the top of the wall.
- Round columns on porches
- Large capitals, especially Corinthian, at the top of the porches of walk-ups.
- Quoins
- Pastiche keystones and imposts over doorway arches
- The use of mutules, dentil courses
- Pediments over the porches.



Classical Revival

Tudor Revival

- Steeply pitched roofs over the entrances
- Multi-pane windows, sometimes diagonal panes
- Crenulation as a cornice detail
- Half-timbering
- Crenulation around the entrance way



Tudor Revival

Prairie

- Casement windows
- Wide, overhanging eaves
- Heavy lintels to emphasize horizontal orientation



Prairie Style

Commercial Structures

c. 1900

Few historic commercial structures exist in the Avenues, South Temple, Central City, Capitol Hill and University districts. Those that do remain were usually used as stores, and were either one- or two-story buildings. Despite the fact that many have been converted into residences, their original purpose is easily discerned.

Characteristics

- One- or two-story
- Flat roof
- The street elevation of the first story is almost all plate glass above a knee wall. There is often a transom above the plate glass.
- There is often a parapet wall on the street elevation, with decorative corbelling.
- Signage was either painted on the building above the transom; most often the business was identified by the use of an awning. The awning was angled (not rounded) with a valance of about 4".

Additional Information

Carter, Thomas and Peter Goss. *Utah's Historic Architecture, 1847-1940*. Salt Lake City, Utah: University of Utah and Utah State Historical Society, 1988.

McAlester, Virginia and Lee McAlester. *A Field Guide to American Houses*. New York: Alfred A. Knopf, 1984.

Rehabilitation Design Guidelines for Historic Residential Properties

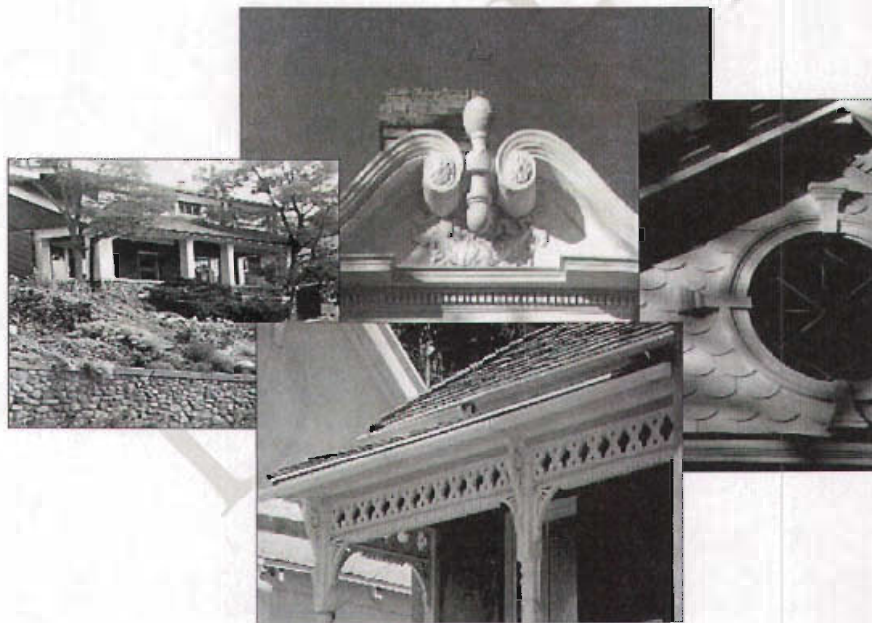

Rehabilitation Design Guidelines Table of Contents

1. Site Features	1: 1-14
2. Materials	2: 1-14
3. Windows	3: 1-12
4. Doors	4: 1-6
5. Porches	5: 1-6
6. Architectural Details	6: 1-4
7. Roofs	7: 1-8
8. Additions.	8: 1-10
9. Accessory Structures	9: 1-5
10. Seismic Design	10: 1-2

DRAFT

Context and Character

A variety of site features are characteristic of early Salt Lake City residential neighborhoods. A house is usually appreciated in its immediate street setting. Individual sites and gardens may share common characteristics which help to define community character.

Fences were popular and often defined property boundaries; masonry walls were used to retain steep hillsides and various paving materials, particularly concrete and sandstone, were used for walkways. A variety of plantings, including trees, lawns and shrubbery also were seen. In a few cases, distinctive lawn ornaments or sculpture were introduced, or an irrigation ditch ran across a site. Each of these elements contributes to the historic character of a neighborhood. They also help to add the variety of scale, texture and materials associated with the streetscape, enriching community experience. Collectively these elements often help to establish the historic and architectural context.

CONTEXT AND CHARACTER	1 : 1
DESIGN OBJECTIVE	1 : 2
GENERAL	1 : 3
HISTORIC FENCES	1 : 3
HISTORIC GRADING	1 : 5
MASONRY RETAINING WALLS	1 : 6
WALKWAYS & SIDEWALKS	1 : 8
DRIVEWAYS	1 : 9
PARK STRIPS	1 : 10
LANDSCAPED MEDIANS OR PARKWAYS	1 : 10
PLANTING DESIGNS & MATERIALS	1 : 11
STREET LIGHTING	1 : 12
SITE LIGHTING	1 : 12



Historic wrought or cast iron fences provide visual richness to the street scene.



Enriching community experience.

Chapter 1. Site Features



Early fencing define the lot and add decorative detail while maintaining the visual relationship between private and public space.

Most residential properties have a progression of spaces leading from the public realm of the street, transitioning into a semi-public/semi-private area of the front yard, to perhaps a semi-private porch and ending with the building entry, and the private realm. This progression may be rather extended, and include a sidewalk area and then a yard with a walkway that leads to a porch. Or, it may be more compressed, with a small stoop near the street edge. Nonetheless, there is in each case a sense of progression from the public to the private realm, and a visual continuity is apparent, contributing to the character of the street scene and context. There is often a demarcation of the identity of the front yard with a low perforate or transparent fence, which at the same time maintains the visual continuity between the house and the street. Where a fence is higher and/or less transparent, it will disrupt this relationship.

Design Objective

Historic site features that survive should be retained, preserved or repaired when feasible. New site features should be compatible with the historic context and the character of the neighborhood.

General

1.1 Historically significant site features should be preserved.

- These may include historic retaining walls, irrigation ditches, gardens, driveways and walkways.
- Fences and street trees are also examples of original site features that should be retained whenever feasible.
- Civic maintenance and improvements should identify, recognize and retain important streetscape features such as sidewalks, parkways, planting strips, street trees and street lighting.



Historic Fences

Originally, painted wood picket fences were used to enclose many front yards. The vertical slats were set apart, with spaces between, and the overall height of the fence was generally less than three feet. This combination of low height and transparency helped to both identify individual sites and property, while retaining the visual relationship between gardens and the streetscape.

Wrought iron and wire fences were also used in early domestic landscapes. Early cast iron and wrought iron frequently add decorative detail and a sense of maturity to the design character of a neighborhood.

Where such fences survive, they should be retained. Often, however, original fences are missing. Replacement with a fence similar in character to that used historically is encouraged in such conditions.

Low fences and walls help to define the identity and richness of parts of an established neighborhood.

Chapter 1. Site Features



A low height and the sense of transparency created by this wall and fence help to retain views to the building and along the street.



A progression of spaces and landscaping from street to building helps to establish the character of the street.

Historic photographs portray fence heights at a much lower level than we are used to seeing today. Consider using a lower fence height to enclose a front yard, in keeping with historic patterns and to retain a sense of continuity along the street frontage.

1.2 An original fence should be retained

- Replace only those portions that are deteriorated beyond repair.

1.3 Use materials that appear similar to that of the original for a replacement fence.

- A painted wood picket fence is an appropriate replacement in many locations.
- A simple metal fence, similar to traditional “wrought iron” or wire, may also be considered.
- Review early examples nearby to identify appropriate design options.
- Fence components should be similar in scale to those seen historically in the neighborhood.

1.4 Design a replacement fence with a “transparent” quality, allowing views into the yard from the street.

- Avoid using a solid fence, with no spacing between the boards.
- Chain link and vinyl fencing are inappropriate as fence materials where they would be visible from the street.

1.5 Consider transparency in the design of higher privacy fencing for the side yard of a corner property.

- This helps to maintain a sense of visual continuity.
- Locate a higher street-facing side fence behind the front facade.

Historic Grading

In some areas, steep topography dictated that building sites be sloped. Portions of the Capitol Hill, University and The Avenues Historic Districts are examples. Yards typically incline steeply in these locations, reflecting the original topography. Elsewhere, in the Avenues and South Temple for example, the grading is often more gentle and provides a unifying visual coherence to the streetscape. This historic grading pattern is an important characteristic that should be retained.

Modifying this historic slope, as it is seen from the street, can negatively affect the historic character of an individual site and also its context. For example, excavating a hillside to create a flat building site, or cutting it into a series of stepped terraces would detract from the historic character. However, in some parts of the city, this has occurred in the back yard. Because altering the historic slope in the back yard has less impact on the historic character of the site, more flexibility may be appropriate for modifying back yards.

1.6 The historic grading pattern and design of the site should be preserved.

- In general altering the overall appearance of the historic grading is inappropriate.
- Where change is considered, it should be subordinate to the overall historic grading character.
- Avoid levelling front gardens and introducing retaining walls where this disrupts the established pattern.

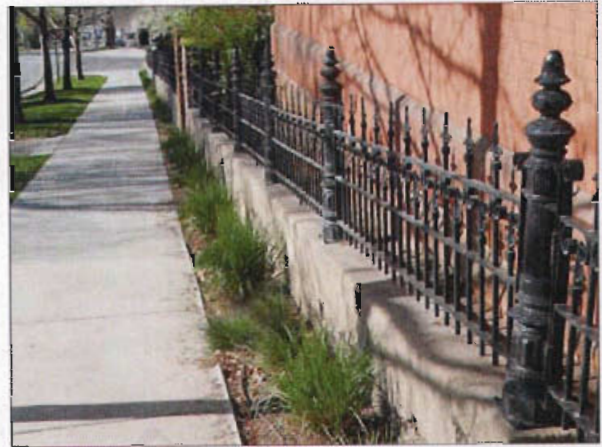

The low retaining wall supporting an ornate historic iron fence contributes significantly to the character of the streetscene.



The form, construction, detailing and materials of a retaining wall may complement both the architectural setting and character of the neighborhood.

Maintenance tip

Many historic masonry retaining walls are damaged by water pressure that builds up behind the wall. This may result from watering a lawn or from natural site drainage. This pressure can erode mortar and it can cause movement of stones.

Water pressure can be reduced by improving the drainage uphill of the wall. Small weep holes or drains also may be created in the wall to allow moisture to pass through.

Masonry Retaining Walls

Sandstone and cobblestone retaining walls were often used in neighborhoods where steep slopes occurred. Many of these walls survive and often are important character-defining features for individual properties and for the districts in which they are found. Some early concrete retaining walls also exist. These should be preserved. As retaining walls frequently align along the edges of sidewalks, they help establish a sense of visual continuity in the neighborhood.

These walls also may have distinct stone coursing and mortar characteristics. Some joints are deeply raked, with the mortar recessed, creating strong shadow lines. Others have mortar that is flush with the stone surface, while some have a bead that projects beyond the stone face. The bond, color and finish of the stone, as well as its mortar style, are distinctive features that contribute to the historic character of a neighborhood.

In some cases, the mortar may have eroded from the retaining wall. Such walls should be repointed, using a soft mortar mix that is similar in color, texture and design to the original (see also the section on Materials). On occasion, some stones are badly deteriorated or may even be missing. New replacement stones should match the original as closely as possible when this occurs.

A new retaining wall will affect the character of the streetscape. This should be considered in its immediate and then broader context. Where a new retaining wall interrupts an established pattern of gradual grading of front lawns it will be less visually and historically appropriate.

1.7 The historic height of a retaining wall wherever possible should be maintained.

- Increasing the height of a wall to create a privacy screen is inappropriate.
- If a fence is needed for security, consider using a transparent wrought iron or wood picket design that is mounted on or just behind the top of the wall. This will preserve the wall, allow views into the yard and minimize the overall visual impact of the new fence.

1.8 The historic finish of a masonry retaining wall should be retained.

- If repointing is necessary, use a mortar mix that is similar to that used historically.
- Repoint using a joint profile that matches the original.
- Painting a historic masonry retaining wall, or covering it with stucco or other cementitious coating, is usually inappropriate.

1.9 Retain and preserve the materials and construction pattern of a historic masonry retaining wall wherever possible.

- If portions of the wall are deteriorated, replace only those portions that are beyond repair.
- Replacement material should match the original in color, texture and finish.
- Masonry units of a size similar to that used historically should be employed.
- Respect the original bond and construction pattern of the stonework.

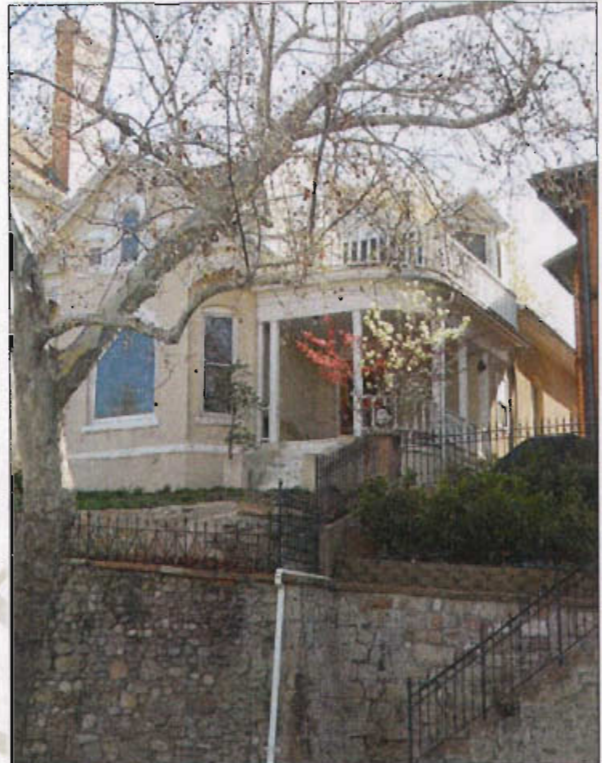

In an area of steep topography a retaining wall may make a significant contribution to the setting and the character of the district.



The natural stone paving and mature landscaping help to establish a sense of maturity.



A shared pattern of walkways and steps can help to create a sense of rhythm in a varied building sequence.

1.10 Consider a new retaining wall in the context of its immediate setting and the established relationship of landscaping within the streetscape.

- A new retaining wall should be avoided where it would disrupt a shared gentle grading between buildings and the street.
- Limit wall height to that defined as characteristic of the setting.
- Design a wall to reflect those found traditionally.
- Use materials that define the character within the immediate and broader setting.

Walkways and Sidewalks

Walkways often contribute a sense of visual continuity on a block and convey a “progression” of walking experiences along the street. This progression, comprised of spaces between the street and the house, begins with a walkway that leads from the sidewalk; this is often in turn punctuated by a series of steps. Because many of the neighborhoods in Salt Lake City were plotted on a grid, this progression of spaces, coupled with landscape features such as fences and walls, is a common feature and greatly enhances the streetscape.

Often this is a common pattern that helps to create a shared rhythm of walkways and steps, helping to unify varied building scales and styles. New site work that alters the historic pattern of the block can negatively affect its visual continuity and coherence. The use of appropriate materials is a key factor in preserving the historic character and the relationship between a historic building, its neighbors and its context.

Historic sidewalks may have a variety of features which establish the age and character of a neighborhood, and which in turn enrich the experience of living there. Natural sandstone paving for example weathers to exhibit the bedding plane 'figuring' of the stone, enhancing the sense of time and maturity in the neighborhood.

1.11 Respect a common historic walkway pattern in form, design and materials wherever possible.

- Review the prevailing patterns in the immediate neighborhood.
- Design alterations or a new walkway to complement a traditional pattern.

1.12 Historic paving materials should be retained where these still occur.

- Early sandstone flags should be retained, and carefully relaid if uneven.
- Replace any broken stones with matching material.
- Consider extending the tradition of natural stone paving where streetscape improvements are considered.

Driveways

Historic driveways are characteristic of many neighborhoods in the city, frequently dating to the original construction of the house and landscaping of the site. These often retain their original paving materials and may demarcate in a change in materials the original two wheel 'drive strips'. A historic driveway, its design and materials, can contribute to the character of the immediate setting of the house and its wider context, adding to the sense of maturity of the neighborhood. Repair of a historic driveway is preferred to its complete replacement, wherever possible. If a new driveway is proposed, the use of drive strips may help to integrate this within its context, especially where it would replace existing grass.

A historic driveway should be retained and repaired wherever possible.

- The driveway layout in original materials should provide a basis from which to repair or replace.
- The 'drive strips' should be retained where these are a historic feature.
- A new driveway should be designed to avoid or minimize the loss of grass, established landscaping and mature trees.



Historic paving will include both natural stone and concrete.



A park strip is often experienced as an extension of the front yard, integrating private and public spaces, and enhancing the established character of the neighborhood.

Park Strips

In many historic neighborhoods in Salt Lake City the streetscape contains park strips, the band of grass between the curb and the sidewalk. These may contain rows of street trees if the park strip is wide enough to support the root system. This coupling of planting strips and street trees provides a rhythm along the block, as well as shade for pedestrians, and should be preserved. Often these are creatively landscaped to reflect the adjacent yard, adding a sense of seasonal variety and landscape maturity to the streetscape.

Only if the park strip is less than 24" wide are impervious materials such as brick pavers, concrete pavers and concrete allowed. Refer to Chapter 21A.48 of the Salt Lake City Zoning Ordinance for information on the landscaping of park strips.

Landscaped Medians or Parkways

A parkway is a large grassed or treed median that lines the center of a street such as along 600 East. It frequently provides a unique and well used recreational and leisure space, and markedly enhance the character of the street. Where they are found, parkways add unique character to the streetscape. Thus, where parkways have been established, they should remain. Where they have been removed consider their reinstatement.

Planting Designs & Materials

While most historic plant materials have been replaced over time, some specimens do survive, and in other situations, the traditional planting pattern has been retained even if new plants have been installed. In the South Temple district, for example, mature street trees are an important historic element of this street. The trees create a border between the street and the buildings and are a character-defining feature of the boulevard and the district. If possible, these historic trees should be retained; if their removal is necessary then replacement trees should conform to the planting pattern of the existing trees.

1.13 Historically significant planting designs should be preserved.

- Preserve a row of street trees which is an established historic feature.
- Maintain existing trees in such a setting that are in good condition.
- Replant with a species that is similar in character to that used historically if removal can't be avoided.
- Replacement of street trees requires approval of the City's Urban Forester.
- Retain historic planting beds and landscape features as part of the established character of a neighborhood wherever possible.
- Utah has a Heritage Tree List, administered by the Sovereign Lands and Forestry Division of the Utah State Natural Resources Department. Owners interested in finding out if a historic tree is located on their property or who are interested in listing a tree, should contact this agency.



Planting design can make a significant contribution.

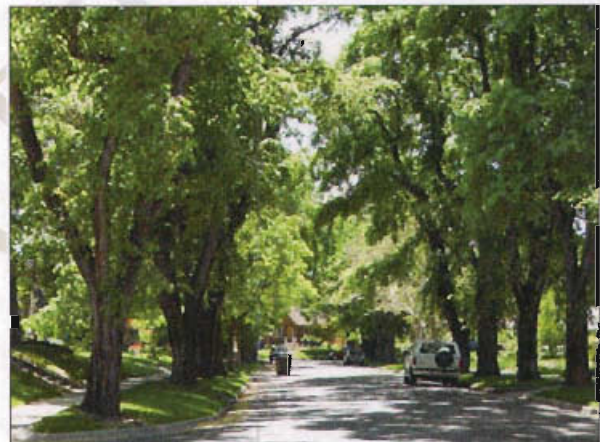

Mature trees are often a character defining feature of the streetscape and the neighborhood.



Trees in the front garden area may complement those nearby in the park strips and lining the street.

Street Lighting

When new street lights are to be installed, they should be designed to be compatible with the neighborhood and with other elements of the streetscape. It is also important that the design for street lighting be subtle and unobtrusive. Often, photographic archives can provide inspiration for the design of a new street lighting system.

1.14 Historic street lighting contributes to the character of the district and should be retained.

- Adaptation to meet current standards of lighting and energy efficiency can often be achieved.

1.15 Design new street lighting as a subtle complement to the streetscape.

- Consider appearance and impact during both daytime and nighttime hours.
- Avoid damage to established features such as early stone paving.



Street lights can quietly contribute to the character and interest of the street scene.

Site Lighting

Lighting in the historic districts can affect the manner in which historic resources are interpreted at night. Lighting is a design feature therefore that is important in site planning; the approach to a lighting scheme should consider lighting intensity, spillover into adjacent properties and fixture design. It should also consider the appreciation of the street at night as a visual composition, and the effect of the overlighting of an individual building within this composition.

1.16 Minimize the visual impacts of site lighting.

- Shield site lighting to avoid glare and spillover onto adjacent properties.
- Focus lighting on walks and entries, rather than up trees and facade planes.
- Lighting intensity and design should not draw undue attention to a particular property at the expense of the appreciation of the street composition.



Lighting the building or the site can similarly complement the architectural setting and character of the street.

Context and Character

Historic residential neighborhoods in Salt Lake City include a spectrum of architectural forms and styles, usually carefully articulated in a variety of primary building materials. These materials are generally of high decorative and structural quality, durable and usually resistant to premature deterioration if understood and in some cases cared for through basic maintenance.

Brick and wood siding are typical primary building materials. Stone and adobe were also used, although adobe frequently was stuccoed or clad with clapboard siding. Terra-cotta and cast stone were used for decorative detailing. Concrete and concrete block were also increasingly used as the 20th century progressed. While wood siding occurred in a variety of forms, painted, horizontal clapboard and novelty siding was the most popular. A variety of lap profiles were used.

In each case, the distinct characteristics of the primary building materials, including the scale of the material unit, its texture and finish, contribute to the historic character of a building. These materials may form the external structural wall or may be the external cladding system. Contrasting materials, colors or textures are often employed for decorative detail and embellishment in the form of framing for doors and windows or belt courses.

The best way to preserve historic building materials is through well-planned maintenance. Wood surfaces should be protected with a good application of paint. Both wood and masonry should be kept dry by preventing leaks from roofs and guttering washing over the surface and also by maintaining positive drainage away from foundations, such that ground moisture does not rise through the wall.

CONTEXT AND CHARACTER	2 : 1
DESIGN OBJECTIVE	2 : 3
GENERAL	2 : 3
MASONRY	2 : 4
WOOD	2 : 7
METAL	2 : 9
CLEANING MATERIALS & METHODS	2 : 10
REPAIR	2 : 11
PAINT & OTHER COATINGS	2 : 12
ADDITIONAL INFORMATION	2 : 14

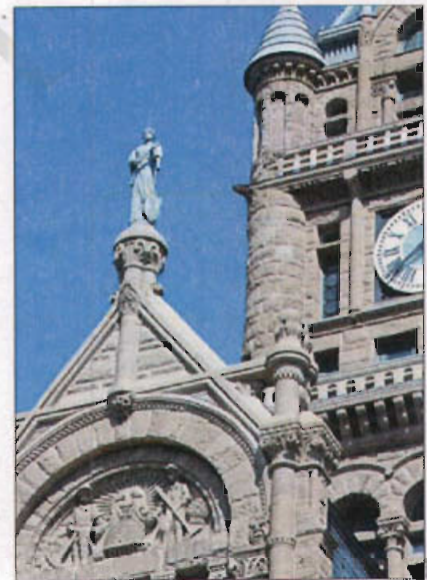

Historic civic and commercial architecture in the city makes rich use of a range of materials, color and finishes.

Typical historic building materials in Salt Lake City

Wood Siding

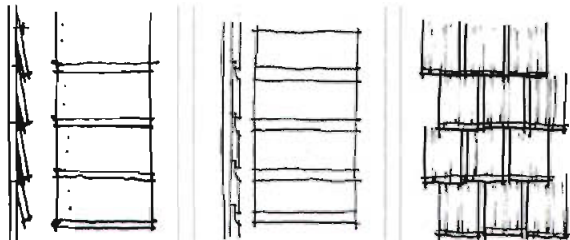

Clapboard

Drop or Novelty

Shingle

Masonry Wall Patterns

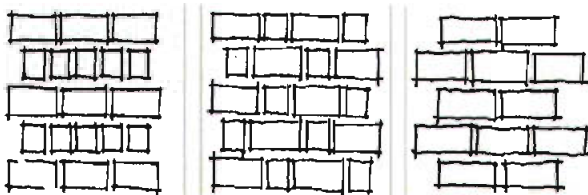

English Brick

Flemish Brick

American Stretcher



Original materials are essential to the integrity of a building and convey a sense of authenticity and maturity.

In some cases, historic building materials may have deteriorated. Horizontal surfaces such as chimneys, sills, and parapet copings are most likely to show the most deterioration because they are more exposed to weather and are more likely to hold water for longer periods.

When deterioration has occurred, repair the material after addressing any other related problems that might be the cause. In most cases damaged materials can be patched or consolidated.

In other situations, however, some portions of the material may be beyond repair. In such a case replacement will be required. With primary historic building materials, the new material should match the original if feasible. If wood siding had been used historically, for example, the replacement also should be wood. In the case of primary materials, replacement in kind is relatively easy because these materials are readily available and are of high quality.

It is important, however, that the extent of replacement materials be minimized, because the original materials contribute to the authenticity and integrity of the property as a historic resource. Even when the replacement material exactly matches that of the original, the integrity of a historic building is to some extent compromised with the loss of original or early materials. This is because the original material exhibits a record of the labor and craftsmanship of an earlier time and this is lost when it is replaced. Original materials also help to define the authenticity, integrity, and help to convey the age, maturity and 'patina' of the building.

It is also important to recognize that all materials will weather over time and that a scarred or weathered finish does not represent an inferior material or structural problems, but simply reflects the age and maturity of the building. This 'patina of age' is a tangible and distinct characteristic of any historic building or neighborhood. In some respects they acquire the wisdom that comes with long-standing experience. Preserving original materials that show signs of wear and age is therefore preferred to their replacement. Cleaning methods, specifically abrasive, high pressure and chemical cleaning, can severely damage or destroy primary building materials, and in general should be avoided.

Design Objective

Primary historic building materials should be preserved in place whenever feasible. When the material is damaged, then limited replacement, matching the original, may be considered. Primary building materials should never be covered or subjected to harsh cleaning treatments.

General

2.1 Primary historic building materials should be retained in place whenever feasible.

- Limit replacement to those materials that cannot be repaired.
- When the material is damaged beyond repair, match the original wherever feasible.
- Covering historic building materials with new materials should be avoided.
- Avoid any harsh cleaning treatments, since these may cause permanent damage to the material.



A variety of brick, stone, terracotta and ceramics, their patterns and textures create a rich visual experience and a sense of human scale.



Brickwork lends itself to an endless variety of creative architectural compositions with associated decorative relief and textures.

Masonry

Masonry includes a range of solid construction materials, including stone, brick, adobe block or brick, stucco, and concrete. The following guidelines apply to the masonry surfaces, features, and details of historic buildings.

Masonry in its many forms is one of the most important character-defining features of a traditional building. Brick, stone, adobe, terra-cotta, ceramics, stucco, cast stone, and concrete are typical masonry construction materials used across the city, reflecting its sequence of settlement and development. Masonry materials of various types exist as walls, cornices, pediments, steps, chimneys, foundations, and functional and/or decorative building features and details.

In a brick wall the particular size of brick used and the manner in which it is laid is a distinctive characteristic. Similarly, the pattern or 'bond' in the construction of a brick or stone wall helps to establish its character. This combines with the choice and nature of the material, the choice of cut, rough and/or dressed stone, to create a unique physical and visual character.

In earlier masonry buildings, a soft mortar was used, which employed a high ratio of lime. (Little, if any, Portland cement was used.) This soft mortar was usually laid with a finer joint than we see today. The inherent color of the material was also an important characteristic; mortars would be mixed using sand colors to match or contrast with the brick. The size of the bricks contributed to the sense of scale of the wall and building, expressed by the profile and color of the mortar joints; both express a range of construction patterns or brick bonds. When repointing such walls, it is important to use a mortar mix that approximates the original in color, texture and strength.

Most contemporary mortars are harder in composition than those used historically. They should not be used in mortar repairs because this stronger material is often more durable than the brick itself, causing it to fracture or spall during movement or swelling. When a wall moves during the normal change in season and temperatures, the brick units themselves can be damaged and spalling of the brick surface can occur.

2.2 Traditional masonry surfaces, features, details and textures should be retained.

- Regular maintenance will help to avoid undue deterioration in either structural integrity or appearance

2.3 The traditional scale and character of masonry surfaces and architectural features should be retained.

- This includes original mortar joint characteristics such as profile, tooling, color, and dimensions.
- Retain bond or course patterns as an important character-defining aspects of traditional masonry.

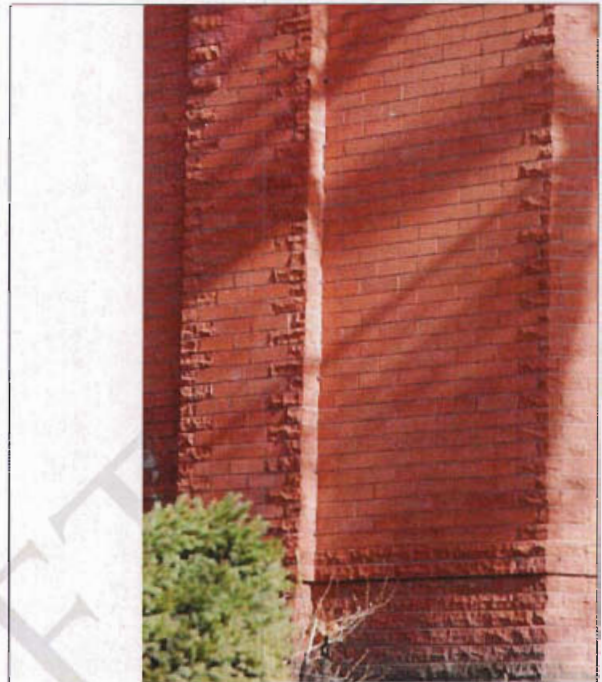

Brickwork, including the bond and mortar joint width and profile, may be an essential component of the architectural character.

Maintenance Tip

When repointing eroded mortar in a masonry wall, use a recipe for new mortar that is similar to the original in color, texture and hardness. This will ensure that damage will not occur from the use of mortar that is harder than the brick or stone, and that the detailed craftsmanship and character of the building is retained.

Originally a mortar mix of 5 parts sand, 2 parts lime, 0 parts cement was used...



Variation in the brick texture and the pointing profile are used in this case to define the wall, the window bay and the chimneys.



Matching the existing brick pattern or bond and the composition of the mortar mix help to ensure the integrity of the brick and stonework and consequently architectural character.

2.4 Match the size, proportions, finish, and color of the original masonry unit, if replacement is necessary.

2.5 The existing mortar mix should be retained if it was designed for the physical qualities of the masonry.

- Retain original mortar in good condition.
- Match the mix of the existing mortar as closely as possible when re-pointing mortar.
- Ensure that the strength of the mortar mix is weaker than the material it bonds, since it will damage the existing brick or stone otherwise.
- Mortar is intended to be the sacrificial (see Glossary) component of a masonry system.
- When the mortar mix design is harder than the strength of the masonry units, the brick or block will be damaged and deterioration accelerated as the new system ages.
- If previous re-pointing mix is comprised of hard cement mortar (e.g. "Portland cement"), this should be removed and the masonry re-pointed with an appropriate design mix.
- Mortar mix design for re-pointing original masonry should be compatible with the qualities of the masonry, local climate characteristics and exposure to extremes of weather.

2.6 Masonry that was not painted traditionally should not be painted.

- Brick has a hard outer layer, also known as the 'fire skin,' that protects it from moisture penetration and deterioration in harsh weather.
- Natural stone often has a similar hard protective surface created as the stone ages after being quarried and cut.
- Painting traditional masonry will obscure and may destroy its original character.
- Painting masonry can trap moisture that would otherwise naturally evaporate through the wall, not allowing it to "breathe" and causing extensive damage over time.

2.7 Protect masonry structures from water deterioration.

- Provide proper drainage so that water does not stand on horizontal surfaces or accumulate in decorative features.
- Provide positive drainage away from masonry foundations to minimize rising moisture.

Wood

Wood has been used historically for framing, exterior siding, trim, ornamental details and in 'log' form as a complete construction material. Traditional wood framing and cladding were usually carefully selected, cut and seasoned. Whether used for construction, principal elements such as windows and doors, or for trim and detail, early wood tends to be tough and durable. It is worth retaining for reasons of historic integrity and its enduring physical qualities. New replacement wood is unlikely to match these same physical qualities, resilience and durability.

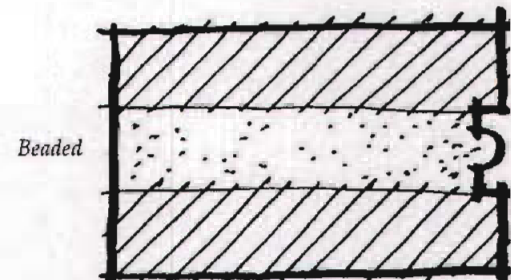
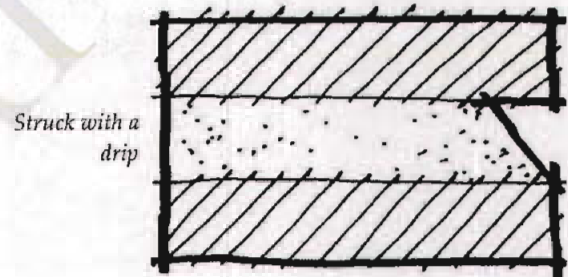
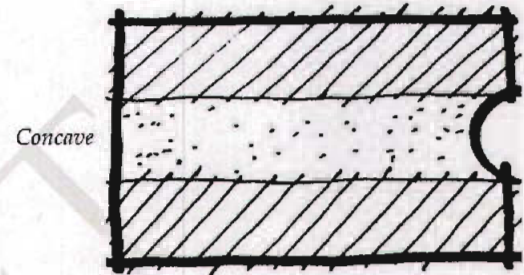
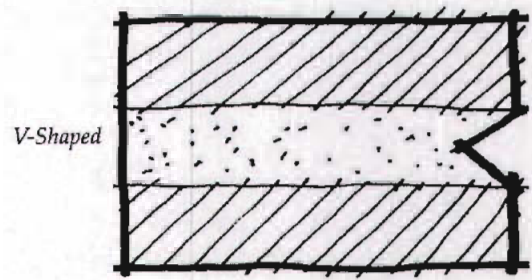

Typical masonry joint types



Wood is perhaps the single most important material for decorative architectural features and detail in all city historic neighborhoods. It is also a very resilient and durable material.

When properly maintained, historic wood will have a long lifespan. Early woodwork should be retained and if necessary repaired. New sections can be readily spliced in. Painted surface finishes should be maintained in order to preserve originally painted exterior wood features and details.

2.8 Original wood siding should be preserved.

- Avoid removing siding that is in good condition or that can be repaired in situ.
- Only remove the siding which has deteriorated beyond repair.
- Match the dimensions, form, style, profile, detail and finish of the original or existing siding, if new siding is required.

2.9 Protect wood features from deterioration.

- Provide proper drainage and ventilation to minimize decay.
- Maintain protective paint coatings to decrease damage from moisture.
- If the building was painted historically, it should remain painted, including siding and trim.

2.10 Repair wood features by patching, piecing-in, consolidating, or otherwise reinforcing the wood wherever necessary.

- Match the form, dimensions, profile, and detail of the original wood feature when patching, piecing in or repairing wood features.

Maintenance Tip

Most wood siding in Salt Lake City was manufactured locally, and can be easily replicated by local mills

2.11 Original wood cladding and siding should not be covered.

- Avoid obscuring these character-defining features of the building.
- Aluminum or vinyl siding applied over original wood siding traps water vapor and moisture, and leads to physical deterioration and failure of new and original building materials.
- Remove non-original or non-traditional siding at the earliest opportunity, for this reason.
- Repair the underlying original siding as required.

Metals

Metals in historic buildings were used in a variety of applications including columns, roofing, canopies, storefronts, window frames, and decorative features. The types of metals used include cast iron, steel, aluminum, lead, bronze, brass, and copper. Metals should therefore be retained and repaired, wherever this is possible

2.12 Architectural metal features that contribute to the historic character of the building should be retained and repaired.

- All original or early metals are part of the historic architectural character of the building.
- Ensure proper drainage on metal surfaces to minimize water retention and deterioration.
- Restore protective coatings, such as paint, on exposed metals that have been traditionally coated.

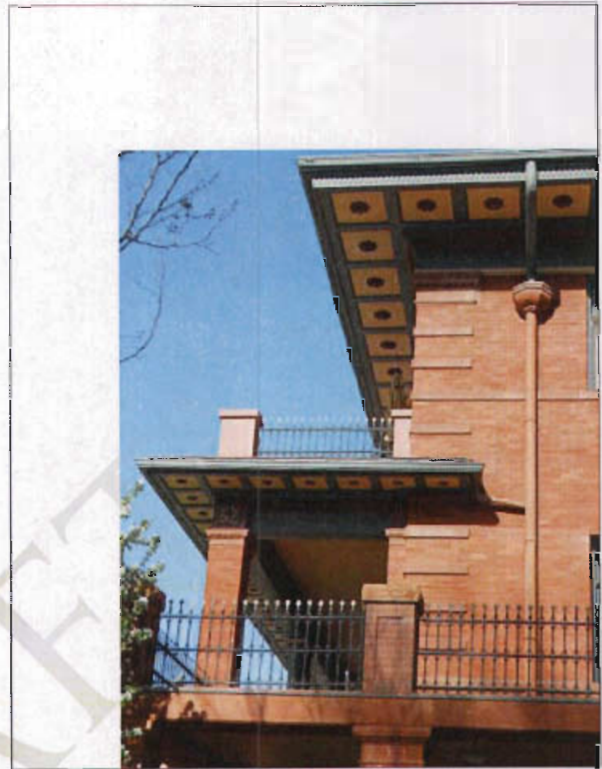

Metal has provided a versatile medium for fine detailing and framing, chosen for its qualities of resilience and adaptability.



A considered color scheme for the building will enhance appreciation of historic and architectural character and its contribution to the streetscape.



Color can be used to complement the texture and qualities of the materials and detailing.

2.13 Repair traditional metal features by patching, consolidating, or otherwise reinforcing the original.

- Only replace the original metal feature in its entirety if the majority of the feature is deteriorated beyond repair.
- New metal should be compatible with the original, not only to preserve visual character but to prevent galvanic reactions and accelerated deterioration of original and/or replacement metal.

Cleaning Materials and Methods

Original building materials rarely need to be cleaned. Some cleaning materials and methods can harm the building fabric. Many cleaners can be harsh and abrasive, often permanently damaging the surface and durability of building materials, such as brick and stone. In particular, abrasive cleaning methods can remove the hard outer layer of masonry material, and thereby accelerate the deterioration and failure of the masonry. When maintaining historic buildings, only cleaning materials and methods that do not harm the original building materials should be used. This is a specialized area of expertise; much irreparable damage can be caused by inexperience or misapplication.

2.14 Cleaning original building materials should be avoided in most circumstances.

2.15 Use the gentlest cleaning method possible to achieve the desired result, if cleaning is needed.

- Avoid abrasive cleaning methods including sandblasting, pressurized water blasting, or other blasting techniques using any kind of materials, such as soda, silica, or nut shells.
- Research appropriate cleaning methods for the material and the location prior to any cleaning procedures.
- Test any proposed cleaning in a small, less visible, location first.
- Hire a specialist in the cleaning of historic buildings to advise on the lowest impact method of cleaning.

Repair

2.16 Repair deteriorated primary building materials.

- Isolated areas of damage may be stabilized or strengthened, using consolidants.
- Resins and epoxies are effective for wood repair.
- Special repair compounds for brick stone and terra-cotta are also available.

2.17 When repointing masonry, preserve original mortar characteristics, including composition, profile, and color.

- In some cases, matching the composition of the historic mortar mix will be essential to the preservation of the brick itself.

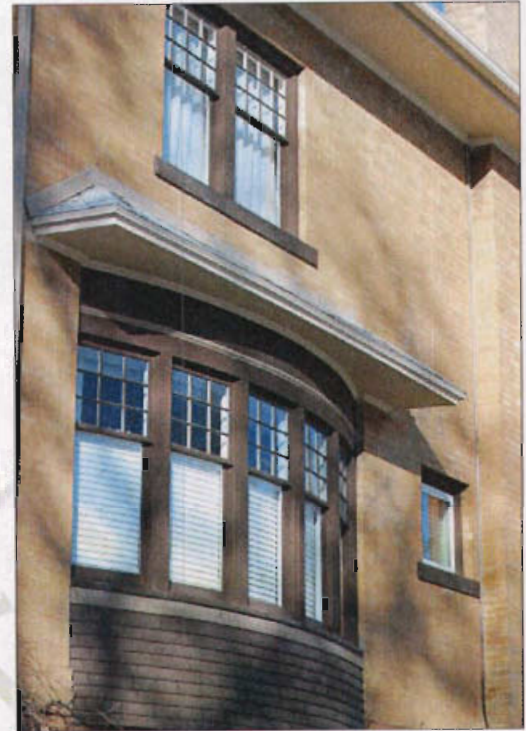

Great care is required to ensure that if cleaning is really required this is achieved using the gentlest means possible, and not using abrasive methods.



The appearance and integrity of the original masonry can be successfully maintained through appropriate repair.



Removing later materials should reveal the original materials, which with care can be successfully repaired.

2.18 Consider removing later covering materials, except where these might have achieved historic significance.

- Repair of the original material may be required after it is uncovered.
- Removal of other materials, such as stucco, should be tested in a small area to ensure that the original material will not be damaged.
- If masonry has a stucco finish, removing the covering may be difficult and may reveal extensive damage to the original material. For example, original brickwork was sometimes chipped to provide a key for the stucco.
- If removing stucco is considered, first remove the material from a test patch to determine the condition of the underlying masonry.

Paint and Other Coatings

Historic buildings that were clad with wood siding were usually painted to protect the wood. Some stucco, brick, and concrete buildings may also have been painted. Masonry surfaces that have not been painted, or that were not painted historically, such as stone, brick, and terra-cotta, should not be painted. Usually these materials were chosen for their decorative as well as their functional qualities. To paint over these characteristics will adversely affect the historic integrity of the building.

Painting brick or stone is rarely if ever warranted to enhance water resistance. Rather, it tends to seal moisture into the wall, hastening deterioration.

Although color is not a matter considered by the City in design review, consider using historic color schemes when undertaking regular maintenance of painted surfaces, including wood windows, doors, and trim.

If the original color scheme is unknown, choose several discrete locations to sample paint layer history. Historic photographs can also be consulted. While these are usually black and white, the photos show relative color values (darks and lights) used on the building. Generally, one muted color would be considered appropriate as a background unifying the building form and mass. For accents, one or two additional colors would be appropriate to highlight building details and trim. In the absence of historic photographs or physical paint layers, an interpretation of paint colors on similar historic buildings is appropriate.

2.19 Prepare the surface or substrate well prior to applying new paint.

- Remove damaged or deteriorated paint only to the next intact layer using the gentlest method possible.
- Do not paint previously unpainted masonry surfaces.
- Consider removing paint from previously painted masonry surfaces that were not painted historically.

2.20 Use paint products designed for the existing materials and the environmental conditions of the locations.

- Follow the manufacturer's directions when applying paint products.
- Use primer coats as directed by the paint manufacturer's instructions. Some latex paints, for example, will not bond well to earlier oil-based paints without a primer coat or proper surface preparation.
- Employ special procedures for removal, preparation for new paint, or encapsulation of older paint layers that may contain lead.



Periodic maintenance of painted surfaces maintains weather resistance and enhances the character of the building.

2.21 Maintaining or re-establishing the historic color scheme is appropriate.

- Research what the historic painting scheme had been and use it as a basis for deciding on a new color scheme if the historic scheme is not otherwise known.
- Sample paint layer history in a discrete location, using a simple means of sanding through each layer revealing the color of different paint layers through time.
- Professional paint analysis and color matching is also an option.
- Use a comprehensive color scheme for a building's entire exterior, so that upper and lower floors and subordinate masses of a building are seen as components of a single structure.

Additional Information

Grimmer, Anne E. *Preservation Briefs 6: Dangers of Abrasive Cleaning to Historic Buildings*. Washington, DC: Technical Preservation Services Division, National Park Service, U.S. Department of the Interior.

London, Mark, *Respectful Rehabilitation - Masonry - How to Care for Old and Historic Brick and Stone*. Washington, DC: The National Trust for Historic Preservation, 1988.

Myers, John H. , revised by Gary L. Hume, *Preservation Briefs 8: Aluminum and Vinyl Siding on Historic Buildings - The Appropriateness of Substitute Materials for Resurfacing Historic Wood Frame Buildings*. Washington, DC: Technical Preservation Services Division, National Park Service, U.S. Department of the Interior, 1984.

Weeks, Kay D. and David W Look, *Preservation Briefs 10: Exterior Paint Problems on Historic Woodwork*. Washington, DC: Technical Preservation Services Division, National Park Service, U.S. Department of the Interior, 1982

Park, Sharon C., *Preservation Briefs 16: The Use of Substitute Materials on Historic Building Exteriors*. Washington, DC: Technical Preservation Services Division, National Park Service, U.S. Department of the Interior.

Context and Character

Windows are some of the most important character-defining features of most historic structures. They give scale to buildings and are an essential element in the architectural composition of individual facades. Distinct window designs and patterns (fenestration) in fact help define many historic building styles.

Windows often are inset into relatively deep openings (reveals) or they have surrounding casings and sash components which have substantial and complex profile dimensions which cast shadows that contribute to the character of the historic style and usually define the age of the building. Because windows so significantly affect the character of a historic structure, the treatment of a historic window, and also the design of a new one, are consequently very important considerations.

Design Objective

The character-defining features of historic windows and their distinct arrangement should be preserved. In addition, new windows should be in character with the historic building. This is especially important on primary facades.

CONTEXT AND CHARACTER	3 : 1
DESIGN OBJECTIVE	3 : 1
WINDOW FEATURES	3 : 2
WINDOW TYPES	3 : 2
WINDOW DETERIORATION	3 : 2
WINDOW REPAIR	3 : 4
ENERGY CONSERVATION	3 : 6
REPLACEMENT WINDOWS	3 : 7
ADDITIONAL INFORMATION	3 : 10



Windows are some of the most important character-defining features of most historic buildings.



Ornamental trim around historic windows should be preserved.

Chapter 3. Windows

Window Features

The size, shape, proportions and profiles of a historic window are among its essential features. Many early residential windows in Salt Lake City were vertically-proportioned, for example. Another important feature is the number of “lights,” or panes, into which a window is divided. Typical windows for many late nineteenth century cottages were of a “one-over-one” sash window type, in which one large pane of glass was hung above another single pane. The design of surrounding window casings, the depth and profile of window sash elements, and the materials of which they were constructed, are also important features. Most early windows were made of wood although some historic metal casement windows are found. In either case, the elements themselves had distinct dimensions, profiles and finishes.

The manner in which windows are combined or arranged on a building facade (the fenestration) also may be distinctly associated with a building style. For example, on some bungalows a large central pane of fixed glass was flanked by a pair of vertically-proportioned casement windows. This compound window frequently occurred on building fronts under broad porches. (See the discussion of individual building styles in the Historic Context and Architectural Styles chapter for additional information about specific window types.) All of these features are elements of historic window designs that should be preserved.

Window Types

Windows types typically found in historic structures in Salt Lake City (see sketches) include:

- Casement - Hinged windows that swing open, typically to the outside
- Double hung sash - Two sash elements, one above the other. Both upper and lower sash slide within tracks on the window jambs.
- Fixed - The sash does not move.
- Single hung sash - Two sash elements, one above the other. Only the lower sash moves.
- Ornamental or specialty windows - Unusual shapes, such as a circular window; or distinct glazing patterns, such as a diamond-shaped, multi-pane window subdivided with wood muntins or lead cames, which may be associated with a particular building style.

These may be fixed or opening.

Deterioration of Historic Windows

Properly maintained, original wood windows will provide excellent service indefinitely. Most problems that occur result from a lack of maintenance. The accumulation of layers of paint on a wood sash for example may make operation difficult. Using proper painting techniques, such as removing upper paint layers and preparing a proper substrate, can solve this problem. Repairs to restore the functionality and efficiency of a double-hung sash, for example, are usually relatively simple.

Often the appearance of peeling paint creates a visual impression of deterioration, when in reality in most cases the wood frame may be structurally sound and stable, and may warrant only remedial maintenance or perhaps minor repair.

Historic Buildings - Typical Window Types

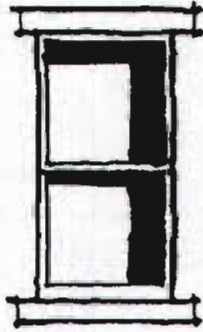

Double-hung Window

Characteristic of:

All styles except Art Moderne or International Style.

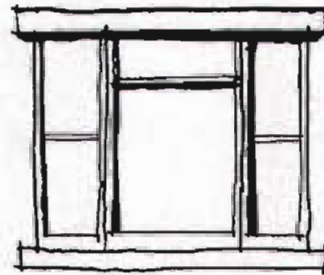

Composite Window

Characteristic of:

- *Classical Revival (simpler than above)*
- *Bungalow*
- *All Victorian styles*
- *Dutch Colonial Revival*
- *Four Square*

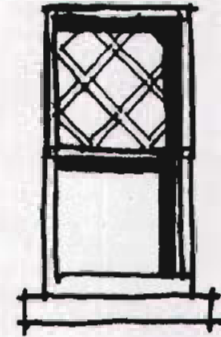

Diamond Pattern Window

Characteristic of:

- *Tudor Revival*
- *Dutch Colonial Revival*

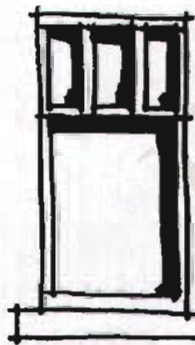

Craftsman Window

Characteristic of:

- *Bungalow*
- *Prairie Style*
- *Foursquare*

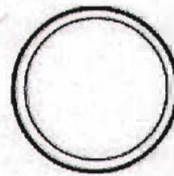

Geometric Window

Characteristic of:

- *Queen Anne*
- *Italianate*
- *Second Empire*
- *Art Moderne*

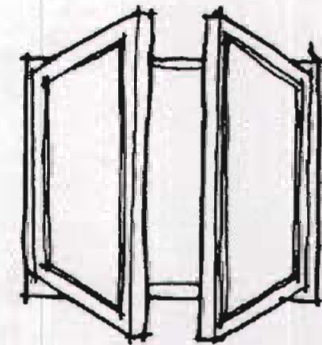

Casement Window

Characteristic of:

- *Tudor Revival*
- *Prairie Style*
- *International Style (with steel muntins)*
- *Arts & Crafts*
- *Ranch*



Ornamental windows such as this oval window and the stained glass window above are character-defining features that often indicate the architectural style of a house.

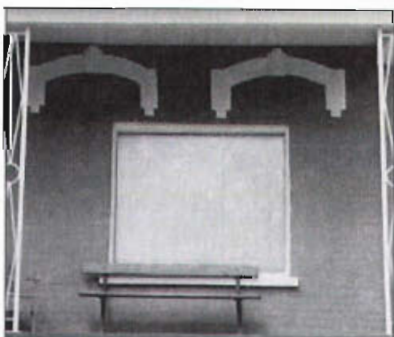

Enclosing a historic window opening on a key character-defining facade destroys much of the home's historic character.

Water damage and the ultra-violet degradation caused by sunlight are of concern. If surfaces fail to drain properly, water may collect and eventually seep through. Condensation during winter months can also cause a problem over time. Deterioration will gradually occur when the paint surface or the putty is cracked, peeling or loose. Decay may make operation of the window difficult and, if left untreated, can result in significant deterioration of window components. In most cases, historic windows are not susceptible to damage if a good coat of paint is maintained and the putty is sound.

Repair of Historic Windows

Whenever possible, repair a historic window, rather than replace it. In most cases it is in fact easier, and more economical, to repair an existing window rather than to replace it. In addition the original materials contribute to the historic character of the building. The materials and craftsmanship tend to be of very high quality, and even when replaced with an exact duplicate window, which is difficult to achieve, a portion of the historic building fabric is lost and therefore such treatment should be avoided. When considering whether to repair or replace a historic window, consider the following:

First, determine the window's architectural significance. Is it a key character-defining element of the building? Typically, windows on the front of the building, and on sides designed to be visible from the street, are key character-defining elements. A window in an obscure location, or on the rear of a structure, may not be. Greater flexibility in the treatment or replacement of such secondary windows may be appropriate.

Second, inspect the window to determine its condition. Distinguish superficial signs of deterioration from the actual failure of window components. Peeling paint and dried wood, for example, may be more superficial than serious problems, and often do not indicate that a window is beyond repair. What constitutes a deteriorated window? A rotted sill may require its replacement, but it does not indicate the need for an entire new window. Determining window condition should occur on a case-by-case basis. However, as a general rule, a window merits preservation, with perhaps selective replacement of components, when more than 50 percent of the window components can not be repaired.

Third, determine the appropriate treatment for the window. Where the window is inoperable, remove excess paint and free or replace any mechanism components that don't work. Surfaces may require cleaning and patching. Some components may have deteriorated beyond repair. Patching and splicing in new material for only those portions that are decayed should be considered in such a case, rather than replacing the entire window. If the entire window must be replaced, the new one should match the original in appearance. (See "Replacement Windows" in following section.)

3.1 The functional and decorative features of a historic window should be preserved.

- Features important to the character of a window include its frame, sash, muntins, mullions, glazing, sills, heads, jambs, moldings, operation, and the groupings of windows.
- Frames and sashes should be repaired rather than replaced whenever conditions permit.

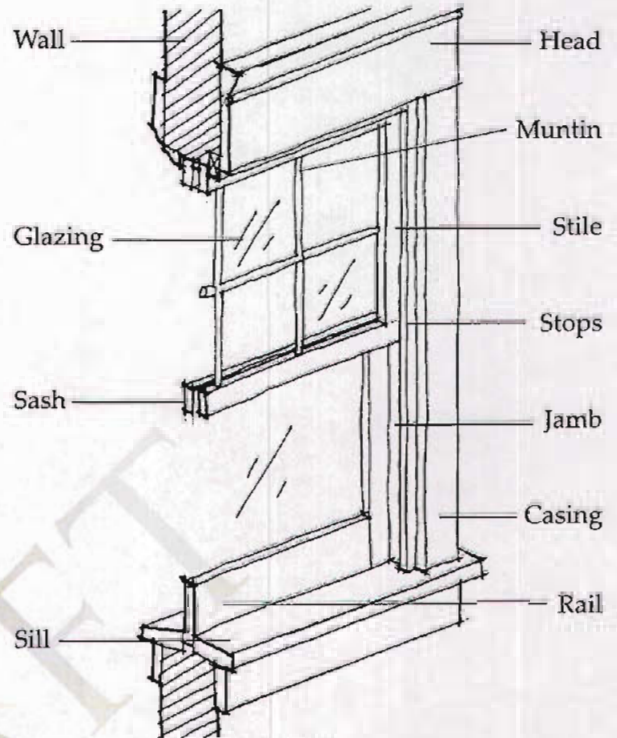

Double-hung window components

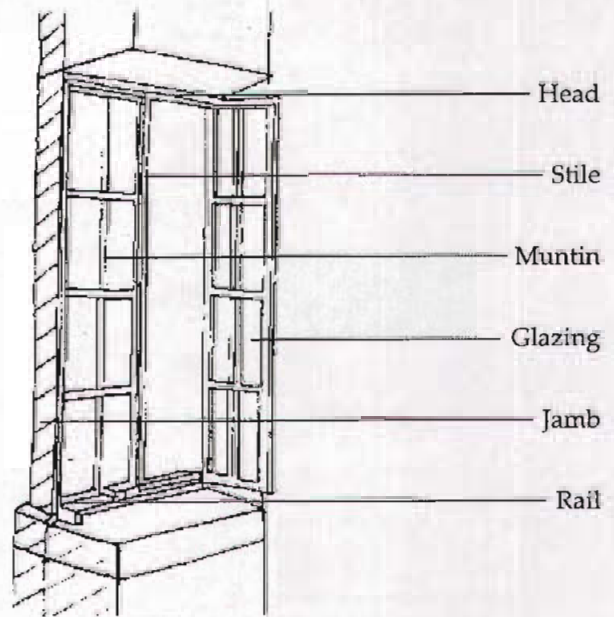

Casement window components



Historic window frames are well constructed and made from tough and durable wood. With minimum maintenance they will last as long as the building. Maintaining the glazing compound and sound paintwork, with minimal maintenance of opening mechanism and sliding surfaces is usually all that is required. When weather-stripped, and with the addition of a storm window, they will match the energy efficiency of replacements and out-perform them in acoustic insulation. They are also maintainable, rather than having to be completely replaced when a component fails.

<http://www.nps.gov/tps/sustainability/research.htm>

3.2 The position, number, and arrangement of historic windows in a building wall should be preserved.

- Enclosing a historic window opening in a key character-defining facade would be inappropriate, as would adding a new window opening.
- This is especially important on primary facades, where the historic ratio of solid-to-void is a character-defining feature. Greater flexibility in installing new windows may be appropriate on rear walls or areas not visible from the public way.

Energy Conservation

In some cases, owners may be concerned that an older window is less efficient in terms of energy conservation. In winter, for example, heat loss associated with an older window may make a room uncomfortable and increase heating costs. In fact, most heat loss is associated with air leakage through gaps around the frame sections of an older window, and is often the result of insufficient maintenance over time. Loss of energy through the single pane of glass found in historic windows is a very small proportion of the total. Glazing compound may be cracked or missing, allowing air to move around the glass. Sash members also may have shifted, leaving a gap for heat loss.

The most cost-effective energy conservation measures for most historic windows are to replace glazing compound, repair the wood members if necessary (usually the frame will be structurally sound) and install weather stripping. These steps will dramatically reduce heat loss, while preserving the character-defining historic features of the window.

If additional energy savings are a concern, consider installing a storm window. This may be applied to the interior or the exterior of the window. It should be designed to match the historic window divisions such that the exterior appearance of the original window is not obscured. In fact, research confirms that a weatherized historic window with an additional storm window (internal or external) will match or exceed the energy efficiency of a replacement window, at a small proportion of the cost. Acoustically the original with storm will be much more efficient.

3.3 To enhance energy efficiency, a storm window should be used to supplement rather than replace a historic window.

- Install a storm window on the interior where feasible. This will allow the character of the original window to be seen from the public way.
- If a storm window is to be installed on the exterior, match the sash design of the original windows.
- A metal storm window may be appropriate.
- The storm window should fit tightly within the window opening without the need for sub frames or panning around the perimeter.
- Match the color of the storm window sash with the color of the window frame; avoid an anodized or a milled (a silvery metallic) finish.
- Finally, set the sash of the storm window back from the plane of the wall surface as far as possible.

Replacement Windows

While replacing an entire window assembly is discouraged, it may be necessary in some cases.



When a window is to be replaced, the new one should match the appearance of the original to the greatest extent possible.



External wood framed storm windows designed to fit the primary framework of the original.

Maintenance tips for Windows

- Maintain a good coat of paint on all exposed surfaces.
- Replace old glazing compound.
- Install new weather-stripping to reduce air leaks.

Chapter 3. Windows



The curved sash glass and frame in these windows are distinctive features that should be preserved.

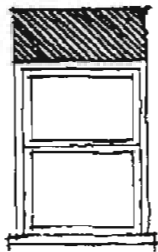

No

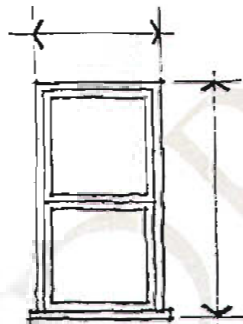

Historic

A replacement window should match the original in its design. The new window (on the left) is smaller than the historic opening and would be inappropriate.



Yes



No

Preserve the historic ratio of window openings to solid wall on a primary facade.

When a window is to be replaced, the new one should match the appearance of the original to the greatest extent possible. To do so, the size and proportion of window elements, including glass and sash components, should match the original. In most cases, the original profile, or outline of the sash components, should be the same as the original. At a minimum, the replacement components should match the original in dimension and profile and the original depth of the window opening (reveal) should be maintained.

A frequent concern is the material of the replacement window. While wood was most often used historically, metal and vinyl clad windows are common on the market today and sometimes are suggested as replacement options by window suppliers. In general, using the same material as the original is preferred. If the historic window was wood, then using a wood replacement is the best approach.

However, it is possible to consider alternative materials in some special cases, if the resulting appearance will match that of the original, in terms of the finish of the material, its proportions and the profiles of the sash members. For example, if a metal window is to be used as a substitute for a wood one, the sash components should be similar in size and design to those of the original. The substitute material also should have a demonstrated durability in similar applications in this climate.

Finally, when replacing a historic window, it is important to preserve the original frame casing when feasible. This trim element often conveys distinctive stylistic features associated with the historic building style and may be costly to reproduce. Many good window manufacturers today provide replacement windows that will fit exactly within historic window casings.

3.4 The historic ratio of window openings to solid wall on a primary facade should be preserved.

- Significantly increasing the amount of glass on a character-defining facade will negatively affect the integrity of the structure.

3.5 The size and proportion of a historic window opening should be retained.

- An original opening should not be reduced to accommodate a smaller window, nor increased to receive a larger window, since either is likely to disrupt the design composition.

3.6 A replacement window should match the original in its design.

- If the original is double-hung, then the replacement window should also be double-hung, or at a minimum appear to be so.
- Match the replacement also in the number and position of glass panes.
- Matching the original design is particularly important on key character-defining facades.

3.7 Match the profile of the sash and its components, as closely as possible to that of the original window.

- A historic wood window has a complex profile within its casing, the sash steps back to the plane of the glazing (glass) in several increments (see illustrations of **frame** sections above and right).
- These increments, which individually only measure in eighths or quarters of inches, are important details.
- They distinguish the actual window from the surrounding plane of the wall.
- The profiles of wood windows allow a double-hung window, for example, to bring a rich texture to the simplest structure.

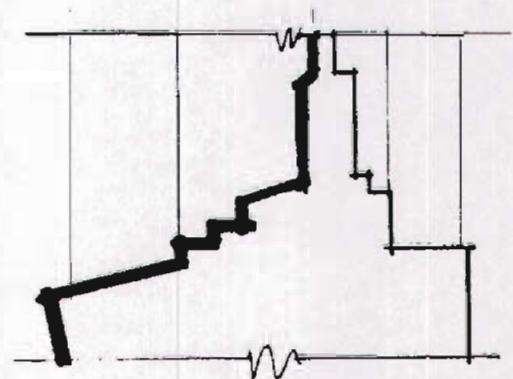

When replacing a historic window, match the profile of the sash and its components, as closely as possible to that of the original window.

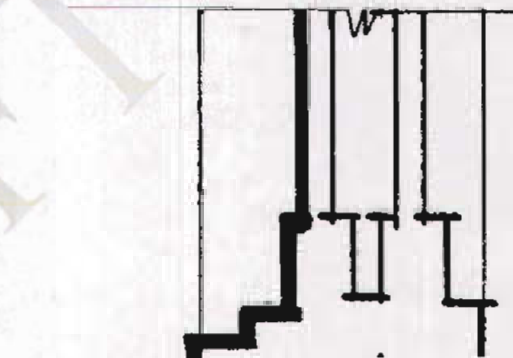

Unacceptable replacement profile

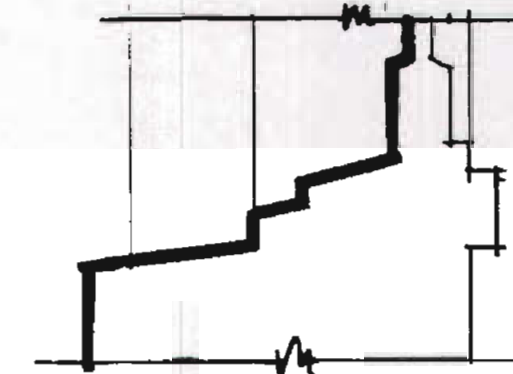

Appropriate replacement profile



Framing sections, profiles and materials define the window type and add considerable detail to the facade.

- In general, it is best to replace wood windows with wood on contributing structures, especially on the primary facades.
- Non-wood materials, such as vinyl or aluminum, will be reviewed on a case-by-case basis, and the following will be considered: Will the original casing be preserved? Will the glazing be substantially diminished? What finish is proposed? Most importantly, what is the profile of the proposed replacement window?

3.8 In a replacement window, use materials that appear similar to the original.

- Using the same material as the original is preferred, especially on key character-defining facades.
- A substitute material may be appropriate in secondary locations if the appearance of the window components will match those of the original in dimension, profile and finish.

Additional Information

Myers, John H. *Preservation Brief 9: The Repair of Historic Wooden Windows*. Washington, DC: Technical Preservation Services, National Park Service, U.S. Department of the Interior. <http://www.nps.gov/history/hps/tps/briefs/brief09.htm>

Park, Sharon C. *Preservation Brief 13: The Repair and Thermal Upgrading of Historic Steel Windows*. Washington, DC: Technical Preservation Services, National Park Service, U.S. Department of the Interior.

<http://www.nps.gov/history/hps/tps/briefs/brief13.htm>

New York Landmarks Conservancy. *Repairing Old and Historic Windows: A Manual for Architects and Homeowners*. Washington, DC: National Trust for Historic Preservation, 1992.

National Trust for Historic Preservation. *New Energy for Old Buildings*. Washington, DC: The Preservation Press, National Trust for Historic Preservation, 1981.

Context and Character

Doors are usually an important character defining feature of a historic structure. They provide scale to a building and help to define the importance of the significant facades, as well as being central to the composition of the individual building facades. Some doors are associated with specific architectural styles, although glass paneled doors with stained glass for example are used in a variety of period designs. Many historic doors are notable for their craftsmanship, materials, placement and finishes. Since an inappropriate door can severely affect the character of a historic house, one should be careful to avoid radical alteration to an old door and to choose a new door that is appropriate to the design of the house.

Design Objective

The character-defining features of a historic door and its distinct materials and placement should be preserved. In addition, a new door should be in character with the historic building. This is especially important on primary facades.

4.1 Preserving the functional, proportional and decorative features of a primary entrance is important.

- These may include: the door, door frame, screen door, threshold, glass panes, paneling, hardware, detailing, transoms and flanking sidelights, and any associated porch or hood.
- Changing the position and function of original front doors and primary entrances should be avoided.
- If necessary, use a replacement door with a design and finish similar to the historic door.

CONTEXT AND CHARACTER	4 : 1
DESIGN OBJECTIVE	4 : 1
MAINTAINING A HISTORIC DOOR	4 : 2
REPAIRING OF HISTORIC DOORS	4 : 2
ENERGY CONSERVATION	4 : 5
REPLACEMENT	4 : 6



Historic ornamental trim contributes significantly to the character of the door, porch and building facade.



The doorway, the proportions of opening and framework, sidelights and transom/fan lights, porch hood, decorative details, and the design of the door itself, combine to celebrate the entrance.

Typical Historic Front Door Designs

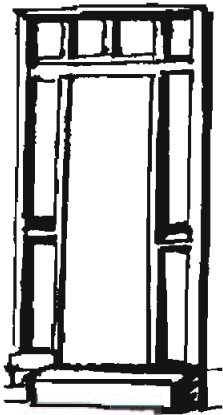

Doors with Transom and Sidelights

Typically a wooden door flanked by sidelights and topped with a rectangular transom.

Craftsman Door

This type of door is distinctive for its thick wood plank design, often with upper glass sashes divided by heavy muntins. Some may have a wood shelf bracket under the sashes.

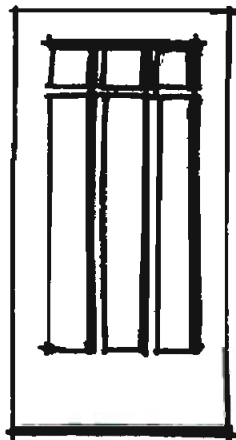

Paneled Door

Wooden door with recessed and/or raised panels.

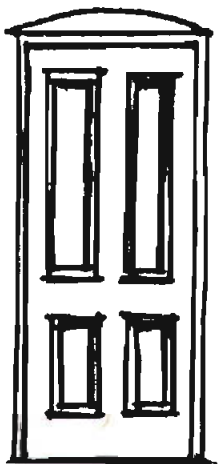

Glass Paneled Door

This type of door has a wide sash of glass in the upper portion of the door. Many Victorian era houses have glass paneled doors that are embellished with turned wood details and etched or stained glass.

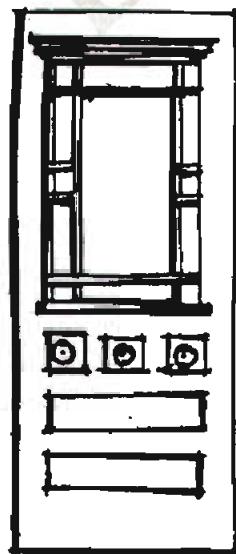

4.2 When a historic door is damaged, repairing and maintaining its general historic appearance is preferred.

Maintaining A Historic Door

Because a historic door is typically of robust wood construction and is often sheltered by a porch, it tends to be durable and long-lasting. Most problems that occur result from a lack of maintenance and from swelling and warping due to seasonal changes. A door may also be worn and sagging because of weathering and constant use. As a result, some historic doors do not properly fit the door frame, allowing moisture and air into the house.

Water, heat and the ultra-violet rays from sunlight are major causes of deterioration. Condensation during winter months also can cause problems with glass panels and sashes on doors. Damage occurs when the painted or finished layer is cracked or peeling. Decay may make operation of the door difficult and, if left untreated, can result in significant deterioration of door components. In most cases, doors are not susceptible to damage if a good coat of paint or varnish is maintained.

Repairing A Historic Door

Repairing a historic door is preferred to replacing it, thereby retaining a character-defining feature and an important aspect of the building's integrity. Repair is also usually much less expensive than replacement and retains the quality and the craftsmanship of the original, which with minimal maintenance will last indefinitely. In many cases a historic door merely needs to be re-hung. Even when replaced with an exact duplicate door, a portion of the historic building fabric is lost. Such treatment should be avoided. When deciding whether to repair or replace a historic door, consider the following:

First

Determine the door's architectural significance. Is it a key character-defining element of the building? Is the front door in a position on the primary facade such that it is visible? Is the design of the historic door indicative of the architectural style or type of the house? If the answer to one or more of these questions is "yes," then preservation is the best approach. A door in an obscure location or on the rear of a structure may not be considered a prominent feature of the house. Thus, greater flexibility in the treatment or replacement of such doors may be considered.

Second

Inspect the door to determine its condition. Is the door hanging wrong or does it lack proper hardware and framing components that make it functional? If so, replacing these elements is appropriate. Check the door to see that it opens and closes smoothly and that it fits in its jamb. Some problems may be superficial ones, such as peeling paint, deteriorated detailing or broken sashes. These are issues that can be remedied without altering the historic character.



The paneled door of this important Italianate building is framed with intricately detailed full and engaged columns supporting a covered porch.



The panelling on this door is echoed in the adjacent sidelight panel, and together with the doorframe detail create a coherent design composition.

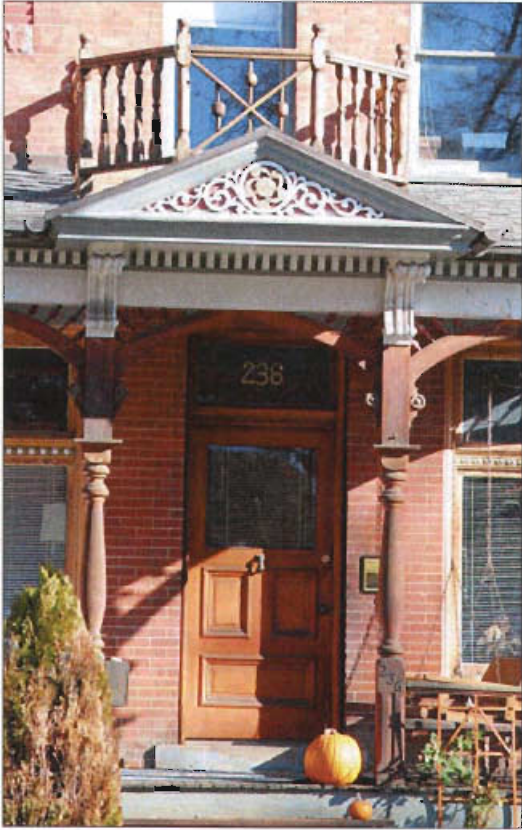

The design composition, original material and details of a door and entranceway contribute to the overall historic character of a building and its context.

Third

Determine the appropriate treatment for the door. In many cases the door may not fit the door jamb or threshold as it should. In this case the hinges and the threshold of the door should be tightened or refit to allow smooth opening and closing of the door. Surfaces may require cleaning and patching. Some components may be deteriorated beyond repair. Patching and splicing in new material for only those portions that are decayed should be considered in such a case, rather than replacing the entire door. If the entire door must be replaced, the new one should match the original in its general appearance and should be in character with the building style. When rehabilitating a historic doorway it is important to maintain original doors, jambs, transoms, window panes and hardware where feasible, even if the door itself is replaced.

Maintenance Tip

Historic and reproduction hardware greatly enhance entries and can readily be found online.

Energy Conservation

In some cases, owners may be concerned that an older door is less efficient in terms of energy conservation. In winter, for example, heat loss associated with an older door may make a room uncomfortable and increase heating costs. In most cases heat loss is associated with air leakage through the space around the door and through glass panes in the door, if it has any.

The most cost-effective energy conservation measures for a typical historic door are to install weather stripping along the door frame and base of the door, to fit the door to the jamb and threshold and to caulk any window panes if required. These measures will dramatically reduce heat loss while preserving historic features.

If additional energy savings are a concern, consider installing a storm door. It should be designed such that the exterior appearance of the original door is not obscured.



A storm door and screen is often designed to complement the doorway and the entrance.



In this case the storm door and screen provide a decorative addition to the original design and detail of the door.



When a historic door or its components are damaged, repair them and maintain their general historic appearance.

Replacement Doors

While replacing an entire door assembly is discouraged, it may be necessary in some cases. When a door is to be replaced, the new one should match the appearance of the original. In replacing a door, one should be careful to retain the original door opening location, door size and door shape. In addition, one should consider the design of the door, choosing a replacement that is compatible with the style and type of the house.

A frequent concern is the material of the replacement door. In general, using the same material as the original is preferred. If the historic door was wood, then using a wood replacement is the best approach.

Finally, when replacing a historic door, it is important to preserve the original door frame when feasible. This is important in keeping the size and configuration of the original door.

4.3 Materials and design that match or that appear similar to the original should be used when replacing a door.

4.4 A design that has an appearance similar to the original door or a door associated with the style of the house should be used when replacing a door.

- When the appearance of the original door is unknown, other properties of similar style and period may provide evidence of appropriate design directions.

Context and Character

Historically porches were popular features in residential design. From the period of the Classical Revival of the nineteenth century, and Period Revivals of the early and middle twentieth century, architects have integrated porches into their buildings. A porch protects an entrance from rain and snow and provides shade in the summer. It also provides a sense of scale and aesthetic quality to the facade of a building. A porch catches breezes in the warmer months, while providing a space for residents to sit and congregate. Finally, a porch often connects a house to its context by orienting the entrance to the street.

Many architectural styles and building types, including Victorian and Craftsman styles, developed with the porch as a primary feature of the front facade. Porches often emphasize the design expression of the house, such as the Prairie style porch, which usually echoes the horizontal orientation of the house. Because of their historical importance and prominence as character-defining features, porches should receive sensitive treatment during exterior rehabilitation and restoration work.

With some more recent, mid-century architectural styles, for example Minimal Traditional, the porch was not a characteristic feature. In such cases adding a porch on the primary facade may be out of character with the building.

Design Objective

Where a porch has been a primary character-defining feature of a front facade, this should continue. In addition, a new (replacement) porch should be in character with the historic building, in terms of scale, materials and detailing.

CONTEXT AND CHARACTER	5 : 1
DESIGN OBJECTIVE	5 : 1
PORCH FEATURES	5 : 2
PORCH DETERIORATION	5 : 2
PORCH ALTERATIONS	5 : 4
PORCH REPAIR	5 : 4
PORCH REPLACEMENT	5 : 5
ADDITIONAL INFORMATION	5 : 7



Historically porches were popular features in residential design. From the period of the Classical Revival of the nineteenth century to the Craftsman and Period Revivals of the early and middle twentieth century, architects have integrated porches into their buildings.

Chapter 5. Porches

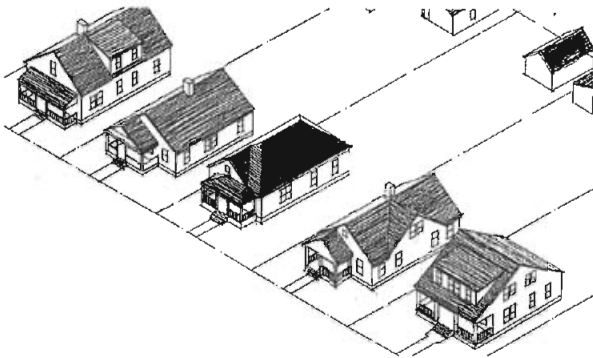

Porches take many forms and have various functions: they orient buildings to the street, integrate a house with its context and are often a key catalyst for social interaction.

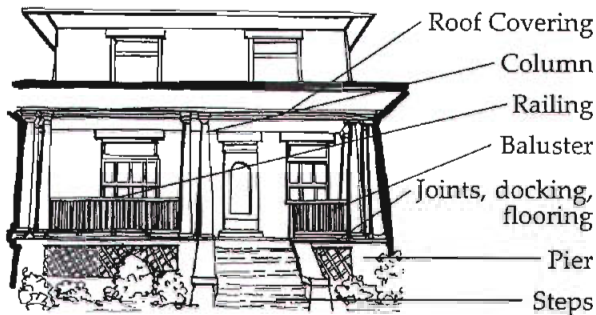

Typical porch components



In this porch, grouped slender columns support an entablature and the gable above. These are key architectural features that should be preserved.

Porch Features

Porches vary as much as architectural styles. They differ in height, scale, location, materials and articulation. Porches may be simple one or two story structures. A porch may project or wrap around much of the ground floor, and may often have elaborate details and finishes. Although they vary in character, most porches have a few elements in common:

- roof
- steps
- columns
- balustrading and railings
- architectural details

These elements often correspond to the architectural style of the house. Therefore the building's design character should be considered before any major rehabilitation or restoration work is carried out.

Porch Deterioration

Because of constant exposure to sun and rain and the fact that a porch is open to the elements, it decays more quickly than other portions of a house. Much deterioration is caused by rain spilling onto the porch from the main roof of the house. If this water does not drain away, then deterioration occurs. Furthermore, if the water is not then channeled away from the foundation of the porch its footings may be damaged. One type of damage is "rising damp," a condition in which masonry absorbs ground moisture and begins to decay. Other problems include weathering of features such as posts, columns, steps and decorative detailing. Peeling paint is a common symptom. In some cases the porch itself may experience sagging or detachment from the house due to settling of the house and/or the porch.

5.1 Preserve an original porch whenever feasible.

- Replace missing posts and railings when necessary.
- Match the original proportions and spacing of balusters when replacing missing ones.
- Unless used historically, wrought iron, especially the “licorice stick” style that emerged in the 1950s and 1960s, is inappropriate.
- Consult Chapter 2 for appropriate materials for masonry, wood, metal and other porch materials.

5.2 The historic materials and the details of a porch should not be removed or covered.

- Removing an original balustrade, for example, is inappropriate.
- Original materials and surfaces, like ceilings, eaves, and columns should not be covered or obscured.



This Classically detailed porch includes paired Doric columns.



Porches create attractive shaded outdoor living space.



Bungalow porch with battered (tapered) columns.



Square columns in various designs create detailed variety and a visual richness in this complementary series of full-width porches.



Wood columns and balustrades were commonly replaced with thin "wrought iron" railings and posts in the 1950s. This compromised the proportions and architectural integrity of the house.



Porch design is usually a notable part of the architectural style and composition, articulating building scale and emphasizing intricate detailing and craftsmanship.

Porch Alterations

Many porches have been altered or removed. Some have had minor changes, such as roof repairs or repainting, while others have been altered to the degree that they have lost much of their character. In many cases a porch may have lost character-defining features, such as balustrades, posts, columns and decorative brackets. These are features that usually define architectural styles, and that may have been replaced by incompatible substitutes. For instance, wood columns and balustrades were commonly replaced with thin "wrought iron" railings and posts in the 1950s. This compromised the proportions and architectural integrity of the house. In the mid-twentieth century it was also fashionable to remove the front porch completely. Since the 1950s, it has also been popular to enclose a front porch to create an interior room, which destroys its historic character and function, and compromises the architectural integrity of the building.

Porch Repair

After discovering structural or cosmetic problems with a porch, one should begin to formulate a strategy for its treatment. The most sensitive strategy is to repair the porch. This treatment is preferred, rather than replacing the porch altogether. In most cases it is in fact easier, and more economical, to repair an existing porch or porch elements (usually constructed of very durable materials) rather than to replace them. This approach is preferred because the original materials and craftsmanship of a porch contribute to the historic character of the building. Even when replaced with an exact duplicate porch, a portion of the historic building fabric is lost.

Porch Replacement

While replacing an entire porch is discouraged, severe deterioration may render it necessary in some cases. When a porch is to be replaced, the first step is to investigate the current porch to determine its history, as well as to ascertain which features, if any, are original. The second step is to research the history of the house to determine the appearance and materials of the original porch and in doing so search for:

- Written documentation of the original porch in the form of historic photographs, sketches and/or house plans;
- Physical evidence of the original porch, including “ghost lines” on walls that indicate the outline of the porch and/or holes on the exterior wall that indicate where the porch may have been attached to the front facade;
- Examples of other houses of the same period and style that may provide clues about the design and location of the original porch. Sanborn insurance maps may help with location.

The most important aspects of the project involve the location, scale, and materials of the replacement porch. It is not necessary to strictly replicate the details of the porch on most “contributing” buildings. It is important, however, that new details be compatible with the design of the original porch and the style of the house.

A rear porch may be a significant feature, including a first or second story sleeping porch. Historically, these served a variety of utilitarian functions and helped define the scale of a back yard. Preservation of a historic rear porch should be considered as an option, whenever feasible; at the same time it is recognized that such a location is often the preferred position for an addition.



This porch has been altered and, as a result, the historic character is compromised.



Repair original elements of the porch and consider reinstating original features which have been lost.



Wood detailing on porches such as this jigsaw ornamentation, or detailed balustrade, should be preserved.



Intricate porch detailing is reflected elsewhere on the building.



This porch reconstruction closely followed photographs of the original.



Enclosing a front porch will significantly compromise the architectural integrity of the house.

Additional Information

Massey, James C. and Shirley Maxwell. "Reading the Old House and Sleeping Porches." *Old House Journal*, (July/August 1995).

5.3 If porch replacement is necessary, reconstruct it to match the original in form and detail when feasible.

- Use materials similar to the original.
- On contributing buildings, for which no evidence of the historic porch exists, a new porch may be considered that is similar in character to those found on comparable buildings.
- Applying decorative elements that are not known to have been used on the house or others like it should be avoided.
- While matching original materials is preferred, when detailed correctly and painted appropriately, fiberglass columns may be acceptable.
- The height of the railing and the spacing of balusters should appear similar to those used historically.

5.4 The open character and integrity of a historic front porch should be retained.

- Enclosing a porch should be avoided.
- Restore a previously enclosed porch to its original open character whenever feasible.

Maintenance Tips for Porches

- *Maintain drainage off of the main roof of the house, as well as off of the roof of the porch.*
- *Channel water away from the foundation of the porch.*
- *Maintain a good coat of paint on all exposed wood surfaces.*

Context and Character

Architectural features and details play several roles in defining the character of a historic structure: they add visual interest, define certain building styles and types, and often showcase superior craftsmanship and architectural design. Features such as window hoods, brackets and columns exhibit materials and finishes often associated with particular styles. Their preservation is therefore important.

Preserving original architectural details is critical to the integrity of the building, and its context. Where replacement is required, one should remove only those portions that are deteriorated beyond repair. Even if an architectural detail is replaced with an exact replica of the original detail, the integrity of the building as a historic resource is diminished and therefore preservation of the original material is preferred. See Chapter 2 on materials and repair.

Design Objective

Architectural details help establish a historic building's distinct visual character; thus, they should be preserved whenever feasible. If architectural details are damaged beyond repair, their replacement, matching the original detailing, is recommended.

6.1 Protect and maintain significant stylistic elements wherever possible.

- Distinctive stylistic features and examples of skilled craftsmanship should be treated with sensitivity.
- The best preservation procedure is to maintain historic features from the outset so that repair or replacement is not required.

CONTEXT AND CHARACTER	6 : 1
DESIGN OBJECTIVE	6 : 1
REPLACEMENT MATERIALS	6 : 2
ADDITIONAL INFORMATION	6 : 4

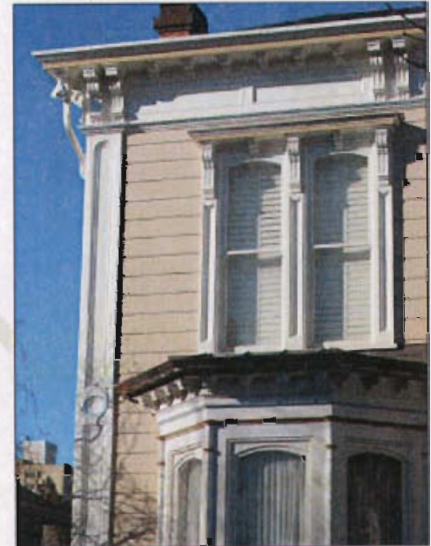

Preserving original architectural details is critical to the integrity of a building and its context.



Features such as window hoods, brackets and columns are often associated with particular styles and therefore their preservation is important.

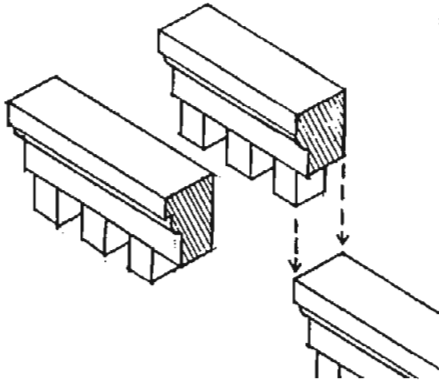

Where replacement of a detail is required, one should remove only those portions that are deteriorated beyond repair.



Moldings and eaves around fascias are important details; this is why they should not be obscured by coverings of synthetic materials.

- Protection includes maintenance through rust removal, caulking, limited paint removal and reapplication of paint, as well as maintenance of roof drainage and water removal systems.

6.2 If replacement is necessary, design the new element using accurate information about the original features.

- The design should be substantiated by physical or pictorial evidence.
- In historic districts, intact structures of similar age may offer clues about the appearance of specific architectural details or features.
- Speculative reconstruction is not appropriate for individual landmarks, since these structures have achieved significance because of their historical and architectural integrity. This integrity may be jeopardized by speculative reconstruction.
- Replacement details should match the original in scale, proportion, finish and appearance.

Replacement Materials

Using a material to match that employed historically is always the best approach. However, a substitute material may be considered when it appears similar in composition, design, color, and texture to the original.

In the past, substitute materials were employed as cheaper, quicker methods of producing architectural features. For example, in the late nineteenth century cast metal window hoods replaced those previously constructed of wood or stone. Many of these historic "substitutes" are now referred to as traditional materials. Just as these historic substitutes offered advantages over their predecessors, many new materials today hold promise.

In Preservation Brief 16, *The Use of Substitute Material*, the National Park Service comments that “some preservationists advocate that substitute materials should be avoided in all but limited cases. The fact is, however, that substitute materials are being used more frequently than ever. They can be cost-effective, can permit the accurate visual duplication of historic materials, and last a reasonable time.” However, these substitute materials should not be used wholesale, but only when it is absolutely necessary to replace original materials with stronger, more durable substitutes.

Substitute materials may be considered when the original is not easily available, where the original is known to be susceptible to decay, or where maintenance may be difficult (such as on a church spire).

Many materials that might appear to be a substitute for the original material have not been in use long enough to have an established record for durability and weathering. Care should be exercised to ensure that they will maintain the appearance of the original after installation. Additionally, certain materials will not readily maintain a coat of paint, and hence may preclude the use of a color scheme to unify the building materials or enhance the architectural details.

Another factor that may determine the appropriateness of using substitute materials for architectural details depends on their location and degree of exposure. For example, lighter weight materials may be inappropriate for an architectural detail that would be exposed to intense wear.

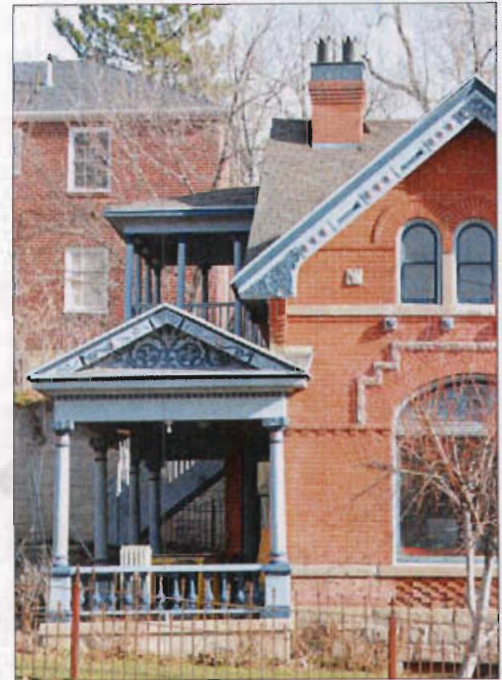

Maintaining the composition and embellishment provided by original architectural detail is essential.



Using non-paintable substitute materials may preclude enhancing architectural details through a carefully considered color scheme.

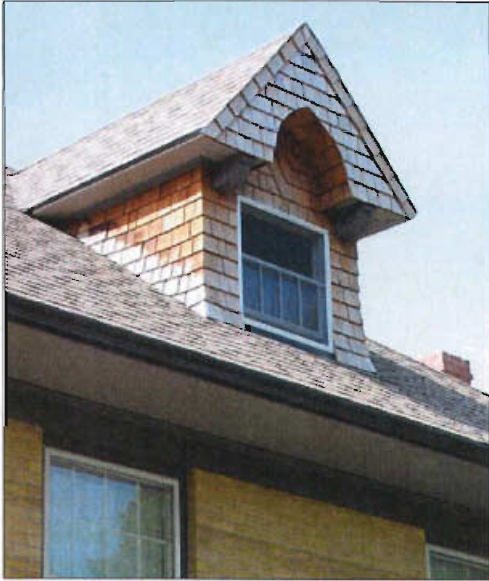

Develop a new design for a replacement feature that is simplified interpretation of a similar feature when the original element is missing and cannot be documented.

6.3 When the original element is missing and cannot be documented, develop a new design for the replacement feature that is a simplified interpretation of the original.

- The new element should relate to comparable features in general size, shape, scale and finish.
- Such a replacement should be identifiable as being new.
- Use materials similar to those that were used historically, wherever feasible.

Additional Information

One of the best sources for historic photographs is **Salt Lake County Records Management**, which maintains early tax photographs for thousands of buildings.

Context and Character

The character and profiles of the roof are major features of most historic buildings. When repeated along the street, the repetition of similar roof forms also contributes to a sense of visual continuity for the neighborhood. In each case, the roof pitch, its materials, size and orientation are all distinct features that contribute to the character of that roof. Gabled and hip forms occur most frequently, although shed and flat roofs appear on some building types.

While the function of a roof is to protect the house from the elements, the roof form is a major element establishing the character of the building. Historically, the roof shape was influenced by climatic considerations, which determined roof forms and pitch. Salt Lake City has seen the construction of various roof forms.

Chimneys and dormers can be major character-defining features of the roofscape, and are often designed to great effect to crown and embellish the architectural composition. In many instances they combine functionality with great decorative impact.

Roof Deterioration

The roof is the building's main defense against the elements. All components of the roofing system are, however, vulnerable to leaking and damage. When the roof begins to experience failure, many other parts of the house may also be affected. For example, a leak in the roof may lead to damage elsewhere, such as attic rafters and wall surfaces.

Common sources of roof leaks include cracks in chimney masonry, failed valley flashings, loose flashing around chimneys and ridges, loose or missing roof shingles, cracks in roof membranes caused by settling rafters, or water backup from plugged valleys, gutters or moss accumulation.

CONTEXT AND CHARACTER	7:1
ROOF DETERIORATION	7:1
DESIGN OBJECTIVE	7:2
ROOF MATERIALS	7:3
GUTTERS & DOWNSPOUTS	7:5
ROOFS ON ADDITIONS	7:6
ADDITIONAL INFORMATION	7:8

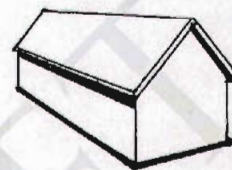

Gabled Roof

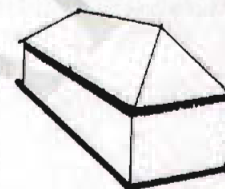

Hipped Roof

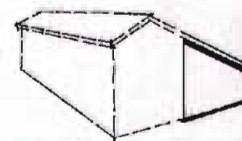

Shed Roof

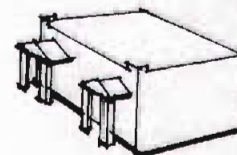

Flat Roof

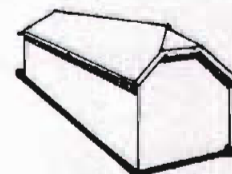

Clipped Roof



Gabled



Hipped



Clipped

Appropriate Roofing Materials

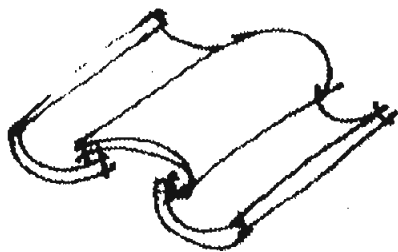

Bar-Tiles

Appropriate for:

Spanish Colonial Revival Buildings



Asphalt Shingles

Appropriate for:

All types



Wood Shingles

Appropriate for:

All except Ranch Style

Chimneys are by nature very exposed, cope with greater temperature extremes and are consequently susceptible to more rapid weathering than other masonry features. Additional maintenance here may be required to avoid premature deterioration.

In repairing or altering a historic roof it is important to preserve its historic character. For instance, one should not alter the pitch of the historic roof, the perceived line of the roof from the street, or the orientation of the roof to the street. The historic depth of overhang of the eaves, which is often based on the style of the house, should also be preserved, as should the roof shape, eaves, cladding and the features of historic dormers.

Design Objective

The character of a historical roof should be preserved, including its form, features and materials whenever feasible.

7.1 The original roof form and features should be preserved.

- Altering the angle of a historic roof should be avoided.
- Maintain the perceived line and orientation of the roof as seen from the street wherever possible.
- Historic chimneys and their details should be retained.
- Historic dormers and their details should be retained.
- Retain and repair roof detailing wherever possible.

7.2 The original historic depth of the eaves should be preserved.

- The shadows created by traditional overhangs contribute to one's perception of the building's historic scale and therefore, these overhangs should be preserved.
- Cutting back roof rafters and soffits or in other ways altering the traditional roof overhang is therefore inappropriate.

Roof Materials

When repairing or altering a historic roof, one should avoid removing historic roofing materials that are in good condition. Where replacement is necessary, such as when the historic roofing material fails to properly drain or is deteriorated beyond use, one should use a material that is similar to the original in style and texture. The overall pattern of the roofing material also determines whether or not certain materials are appropriate. For instance, cedar and asphalt shingles have a uniform texture, while standing seam metal roofs create a vertical pattern.

The color of the repaired roof section should also be similar to the historic roof material. Wood and asphalt shingles are appropriate replacement materials for most roofs. A specialty roofing material, such as tile or slate, should be replaced with a matching material whenever feasible.

Unless the existence of a historic metal roof can be demonstrated, either by existing material or through historic documentation such as photographs, the use of metal shingle or standing seam roofs on contributing structures should be avoided because of their texture, application and reflectivity.

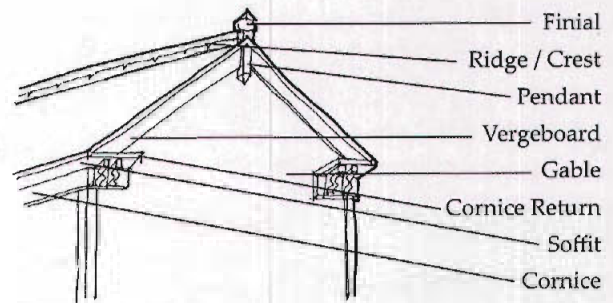

Elements of a Roof



Natural slate is rare in the city and is the most durable of traditional roof materials, usually requiring only piecemeal replacement of damaged individual slates.



Eave profiles & rafter tails are key parts of the design.

Chapter 7. Roofs

Appropriate Eaves Depths on Various Architectural Styles

Eave: The lowest part of the roof. It is the section of a roof that projects beyond the juncture of the roof and the wall.



Vernacular Building

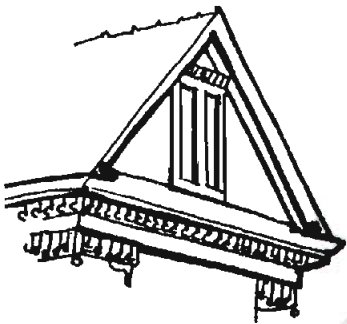

Queen Anne Style

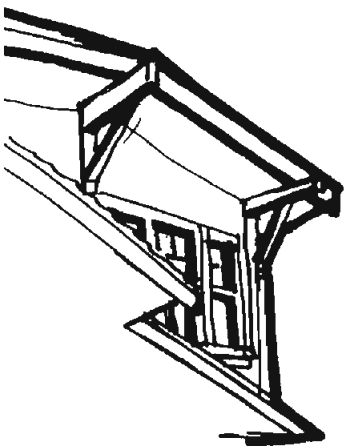

Bungalow

7.3 Preserve original roof materials wherever feasible.

- Removing historic roofing material that is in good condition should be avoided.
- Where replacement is necessary, use materials that are similar to the original in both style and physical qualities wherever possible.
- Use a color that is similar to that seen historically.
- Specialty materials such as tile or slate should be replaced with matching material whenever feasible; replacement of a few individual units may be all that is required with these durable materials.



Asphalt shingles are the typical and appropriate roofing material for this style and period of architecture.

Maintenance Tips for Roofs

- Maintain gutters and downspouts in good condition.
- Keep gutters and downspouts free from debris to ensure proper drainage.
- Patch holes in gutters and downspouts to keep water from seeping onto walls and foundations.
- Install gutters in a manner that is not detrimental to historic building materials.
- Ensure that downspouts drain away from the foundations of the building.

Gutters and Downspouts

Gutters and downspouts are mechanisms for diverting water away from a structure. Without this drainage system, water would splash off the roof onto exterior walls and run along the foundation of the building. If gutters and downspouts are to perform adequately, certain requirements should be met. They must be large enough to handle the discharge. They must have sufficient pitch to carry the water off quickly. They must not leak. They must not be clogged with debris.

Because of low rainfall many residential buildings in Salt Lake City were not designed with any drainage system, or only a partial system (e.g. over entryways). Installation of a new system, where none previously existed, is appropriate if drainage is an issue. These should be designed to have least impact on historic materials, and not obscure important design features (such as rafter tails, cornices, etc.) if possible.



Gutters and downspouts may be a considered part of the building design.

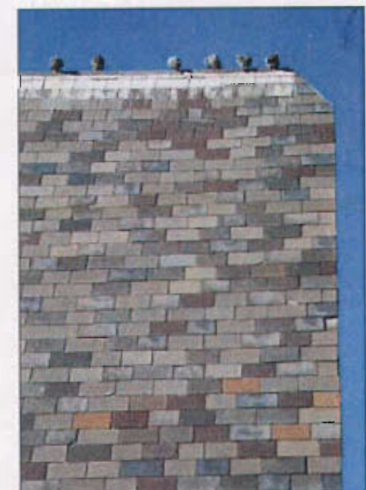

Cedar, clay and slate create special roof texture, color and character.

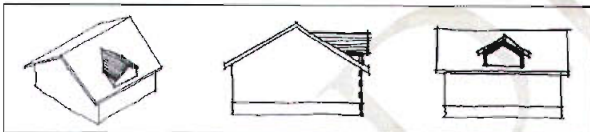

Gabled Dormer: appropriate for most architectural styles.



Hip Dormer: appropriate for most architectural styles.

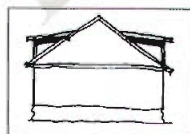

Shed Dormer: appropriate for Bungalow styles.

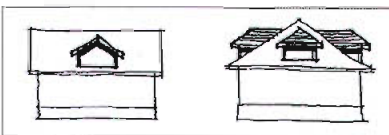

*Gable roof Hip roof
Place a new dormer such that the roof line is preserved, as in the sketches, above.*

Roofs on Additions

Roof Top, Side or Rear Additions

It is important that the roof form of an addition be compatible with the roof form of the primary structure, in terms of its pitch and orientation. In planning a roof top addition, one should avoid altering the angle of the roof and instead should maintain the perceived historic roof line, as seen from the street.

Dormers

Historically a dormer was sometimes added to create more head room in upper floors or attic spaces: it typically had a vertical emphasis and was usually placed singly or in a pair on a roof. One exception to this would be a more horizontal proportion often found in the bungalow style. A dormer did not dominate a roof form, as it was subordinate in scale to the primary roof. Thus, a new dormer should always read as a subordinate element to the primary roof plane. A new dormer should never be so large that the original roof line is obscured. It should also be set back from the roof edge and located below the roof ridge in most cases. In addition, the style of the new dormer should be in keeping with the style of the house.

7.4 When planning a roof-top addition, the overall appearance of the original roof should be preserved.

- An addition should avoid interrupting the original ridgeline whenever possible.
- See also the design guidelines for Additions in Chapter 8.

7.5 The visual impact of skylights and other rooftop devices should be minimized

- Skylights or solar panels should not be installed to interrupt the plane of the historic roof.
- They should be lower than the ridgeline, when possible.
- Flat skylights and solar panels that are parallel with the roof plane may be considered on the rear and sides of the roof. Avoid locating a skylight or solar panel on a front roof plane wherever possible.



7.6 Conjectural materials or features on a roof should be avoided.

- Applying a modern material that is supposed to look like slate but is not slate, to a contributing structure, for example, will overpower and detract from the architectural integrity of the home.
- Adding elaborate eave details or a widow's walk (an ornate railing around the roof ridge) on a house, where there is no evidence that any existed, creates a false impression of the home's original appearance, and is inappropriate.



Dormer design is usually an integral part of the roof composition.

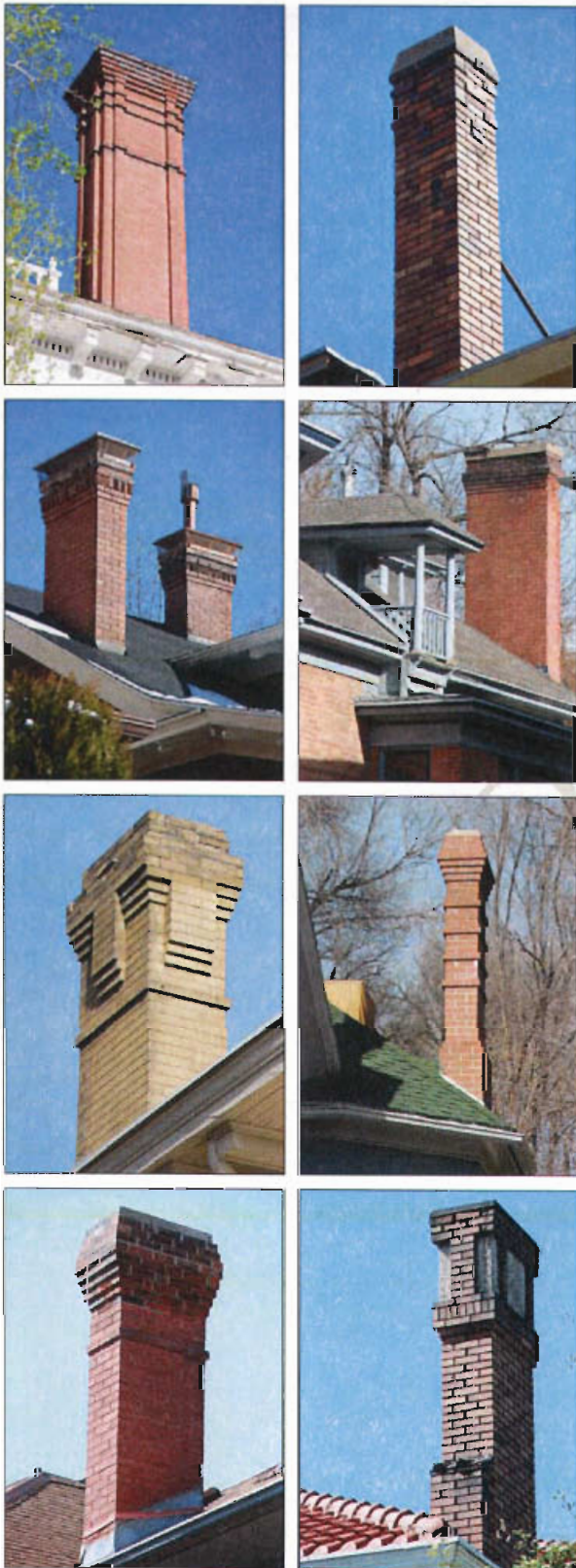

Additional Information

Park, Sharon C. *Preservation Briefs 19: The Repair and Replacement of Historic Wooden Shingle Roofs*. Washington, D.C.: Technical Preservation Services, National Park Service, U.S. Department of the Interior.

Levine, Jeffrey S. *Preservation Briefs 29: The Repair, Replacement and Maintenance of Historic Slate Roofs*. Washington, D.C.: Technical Preservation Services, National Park Service, U.S. Department of the Interior.

Grimmer, Anne E. and Paul K. Williams. *Preservation Briefs 30: The Preservation and Repair of Historic Clay Tile Roofs*. Washington, D.C.: Technical Preservation Services, National Park Service, U.S. Department of the Interior.

Pieper, Richard. *Preservation Tech Notes: Metals #2: Restoring Metal Roof Cornices*. Washington, D.C.: Technical Preservation Services, National Park Service, U.S. Department of the Interior.

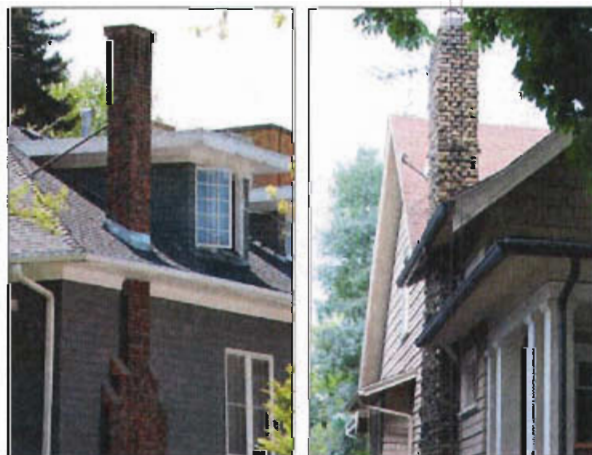

Context and Character

Over time, additions were made to many historic buildings as residents needed more space. In some cases, an owner would add a wing for a new bedroom, or to expand the kitchen.

An early addition typically was subordinate in scale and character to the main building. The height of the addition was usually positioned below that of the main structure and was often located to the side or rear, such that the primary facade remained unaltered.

An addition was often constructed of materials that were similar to those in use historically; clapboard siding, brick and vertical, narrow bead boards were the most common. In some cases, owners simply added dormers to an existing roof, creating more usable space without increasing the footprint of the structure.

This tradition of adding onto historic buildings should be continued. It is important, however, that new additions be designed in such a manner that they preserve the historic character of the original building.

Design Objective

If a new addition to a historic building is considered, it should be designed to ensure that the early character is maintained. Older additions that have taken on significance also should be considered for preservation.

Existing Additions

Some early additions may have taken on historic significance. One constructed in a manner that was compatible with the original building, and that is also associated with the period of historic significance, may merit preservation in its own right. Such an addition should be carefully evaluated before developing plans for its alteration.

CONTEXT AND CHARACTER	8 : 1
DESIGN OBJECTIVE	8 : 1
EXISTING ADDITIONS	8 : 1
BASIC PRINCIPLES FOR NEW ADDITIONS	8 : 2
ROOFTOP OR ATTIC ADDITIONS	8 : 6
GROUND LEVEL ADDITIONS	8 : 7
ADDITIONAL INFORMATION	8 : 8



This addition to the rear adopts similar design language, detailing and materials.



This recent addition reflects the design traditions of the original with a change in material to siding. The change from original to new is emphasized by a break in the wall plane and roof plane.

Chapter 8. Additions

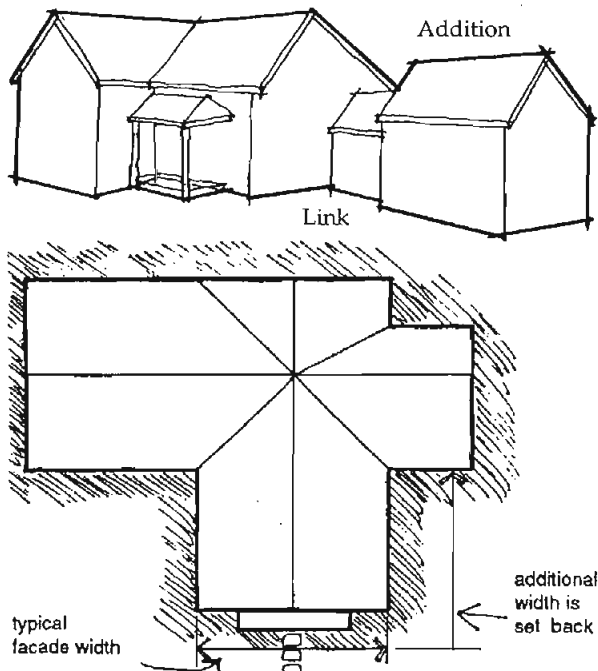

Set back an addition from historically important primary facades in order to allow the original proportions and character to remain prominent, or set the addition apart from the historic building and connect it with a connecting "link" (Top).



This rear addition respects the principal building by continuation of wall plane, eaves and bracket details, while changing the materials and fenestration.

In contrast, more recent additions usually have no historic significance. Some later additions in fact detract from the character of the building through the use of incompatible materials, design and/or location, and may also obscure significant historic architectural features. Where this is the case removing such noncontributing additions should be considered.

Basic Principles for New Additions

When planning an addition to a historic building or structure, one should minimize negative effects that may occur to the fabric and the character of the building. With the objective of designing an addition which is sensitive to the character and integrity of the building, several considerations should be borne in mind. All efforts should be made to build within the existing envelope, using basement and attic space whenever possible. If the only option is outside this envelope then it is preferable to design for a horizontal addition, to the rear rather than the side if possible. If building upward appears to be the only solution then a house with a steeper roof pitch presents an easier design challenge than one with a shallow pitch.

While some destruction of historic materials is almost always a part of constructing an addition, such loss should be minimized. Locating an addition such that existing side or rear doors may be used for access, for example, will help to minimize the amount of historic wall material that must be removed.

The addition also should not affect the perceived character of the building. In most cases, loss of character can be avoided by locating the addition to the rear. The overall design of the addition also should be in keeping with the design character of the historic structure. At the same time, it should be distinguishable from the historic portion, such that the evolution of the building can be understood.

This can be achieved in a variety of subtle ways. Keeping the size of the addition smaller and subservient, in relation to the main structure, will also help to minimize its visual impacts. If an addition must be larger, it should be set apart from the historic building, and connected with a smaller linking element. This will help maintain the perceived scale and proportion of the historic portion of the building.

It is important that the addition should not obscure significant features of the historic building. If the addition is set to the rear, it is less likely to affect such features.

In historic districts, one should consider the effect the addition may have on the character of the district, as seen from the public right of way. A side addition, for example, may change the sense of rhythm established by the side yards in the block. Locating the addition to the rear could be a better solution in such a case.

Two distinct types of additions should be considered: ground level additions, which involve expanding the footprint of the structure, and attic additions, which often are accomplished by installing new dormers to provide more headroom in an attic or second floor space. In either case, an addition should be sited such that it minimizes negative effects on the building and its setting. At the same time, the roof pitch, materials, window design and general form should be compatible with the context.

8.1 An addition to a historic structure should be designed in a way that will not destroy or obscure historically important architectural features.

- Loss or alteration of architectural details, cornices and eave lines, for example, should be avoided.



Small rear addition of individual design and materials, though in keeping with the design character and materials of the original building.



Larger rear addition incorporating garage space with accommodation above.

Chapter 8. Additions



Rear addition with second story space above designed to complement and be distinguished from the original house.



Small staggered rear addition continuing the axis and eavesline of the residence and distinguished by design and materials.



This rear addition continues the design tradition and language of the original with a change in external materials.

8.2 An addition should be designed to be compatible in size and scale with the main building.

- An addition should be set back from the primary facades in order to allow the original proportions and character of the building to remain prominent.
- The addition should be kept visually subordinate to the historic building.
- If it is necessary to design an addition that is taller than the historic building, it should be set back substantially from significant facades, with a “connector” link to the original building.

8.3 An addition should be sited to the rear of a building or set back from the front to minimize the visual impact on the historic structure and to allow the original proportions and character to remain prominent.

- Locating an addition at the front of a structure is usually inappropriate.

8.4 A new addition should be designed to be recognized as a product of its own time.

- An addition should be made distinguishable from the historic building, while also remaining visually compatible with historic features.
- A change in setbacks of the addition from the historic building, a subtle change in material, or the use of modified historic or more current styles are all techniques that may be considered to help define a change from old to new construction.
- Creating a jog in the foundation between the original building and the addition may help to establish a more sound structural design to resist earthquake damage, while helping to define it as a later addition.

8.5 A new addition should be designed to preserve the established massing and orientation of the historic building.

- For example, if the building historically has a horizontal emphasis, this should be reflected in the addition.

8.6 A new addition or alteration should not hinder one's ability to interpret the historic character of the building or structure.

- A new addition that creates an appearance inconsistent with the historic character of the building is inappropriate.
- An alteration that seeks to imply an earlier period than that of the building should be avoided.
- An alteration that seeks to imply an inaccurate variation on the historic style is inappropriate.
- An alteration that covers historically significant features should be avoided.

8.7 When planning an addition to a building, the historic alignments that may exist on the street should be preserved.

- Some roof lines and porch eaves on historic buildings in the area may align at approximately the same height.
- An addition should not be placed in a location where these relationships would be altered or obscured.



Addition to the rear of this house adopts the scale and design of the original and is clearly identified by a change in materials.



The rear addition steps back from the side facade of the house and integrates two story accommodation in a manner which does not dominate the original building.



Recent garage with accommodation above designed to reflect scale and character of the context.



Rear addition designed to echo the original scale and form.

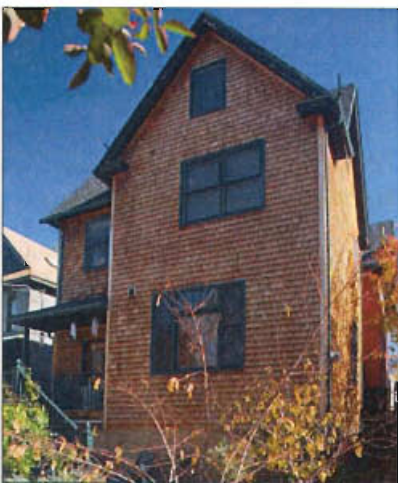

Front and rear views of substantial rear addition adopting original design cues.

8.8 Exterior materials that are similar to the historic materials of the primary building or used historically should be considered for a new addition.

- Painted wood clapboard, wood shingle and brick are typical of many historic residential additions.
- See also the discussion of specific building types and styles, in the History and Architectural Styles section of the guidelines.
- Brick, CMU, stucco or panelized products may be appropriate for some modern buildings

8.9 Original features should be maintained wherever possible when designing an addition.

- Construction methods that would cause vibration which might damage historic foundations should be avoided.
- New drainage patterns should be designed to avoid adverse impacts to historic walls and foundations.
- New alterations also should be designed in such a way that they can be removed without destroying original materials or features wherever possible.

8.10 The style of windows in the addition should be similar in character to those of the historic building or structure where readily visible.

- If the historic windows are wood, double-hung, for example, new windows should appear to be similar to them, or a modern interpretation.

Rooftop or Attic Additions

8.11 When designing a rooftop or attic addition, the mass and scale should be subordinate to the scale of the historic building.

- An addition should not overhang the lower floors of the historic building in the front or on the sides.

8.12 A rooftop addition should be set back from the front of the building.

- This will help preserve the original profile of the historically significant building as seen from the street.
- Greater flexibility may be considered in the setback of a dormer addition on a hipped or pyramidal roof.

8.13 The roof form and slope of the addition should be in character with the historic building.

- If the roof of the historic building is symmetrically proportioned, the roof of the addition should be similar.
- Eave lines on the addition should be similar to those of the historic building or structure.
- Dormers should be subordinate to the overall roof mass and should be in scale with those used originally on the building (or on similar styles of building if none are present originally).



Rear addition reflecting form and scale and distinguished by wall plane, fenestration, detail and materials.



Separate and linked addition including garage and accommodation space.



Second story addition to a historic plan form, closely reflecting the original design and identified by a change in materials.



Ground Level Additions

8.14 A new addition should be kept physically and visually subordinate to the historic building.

- The addition should be set back significantly from primary facades.
- The addition should be consistent with the scale and character of the historic building or structure.
- Large additions should be separated from the historic building by using a smaller connecting element to link the two where possible.

8.15 Roof forms should be similar to those of the historic building.

- Typically, gable, hip and shed roofs are appropriate.
- Flat roofs are generally inappropriate, except where the original building has a flat roof.

8.16 On primary facades of an addition, a 'solid-to-void' ratio that is similar to that of the historic building should be used.

- The solid-to-void ratio is the relative percentage of wall to windows and doors seen on the facade.

Additional Information

Weeks, Kay D., *Preservation Briefs #14: New Exterior Additions to Historic Buildings: Preservation Concerns*. Washington, D.C.: Technical Preservation Services, National Park Service, U.S. Department of the Interior, 1987.

Bock, Gordon. "Making Sense of Sensitive Additions, Ways to Get a Handle on Enlarging Old Houses". *Old House Journal*, May/June, 1995.

Context and Character

Accessory structures include original or early garages, carriage houses or sheds. Traditionally these structures were important elements of a residential site. Because secondary structures help interpret how an entire site was used historically, their retention and preservation is strongly encouraged.

Design Objective

Significant historic accessory structures should be preserved when feasible. This may include preserving the structure in its present condition, rehabilitating it or executing an adaptive use so that the accessory structure provides new functions. Newly constructed secondary structures should remain subordinate to the primary building, and compatible in mass and scale.

CONTEXT AND CHARACTER	9 : 1
DESIGN OBJECTIVE	9 : 1
HISTORY OF SECONDARY STRUCTURES	9 : 2
PRESERVING & REHABILITATING HISTORIC ACCESSORY STRUCTURES	9 : 3
PRIMARY MATERIALS	9 : 3
ROOF FORM & MATERIALS	9 : 3
ADDITIONAL INFORMATION	9 : 4

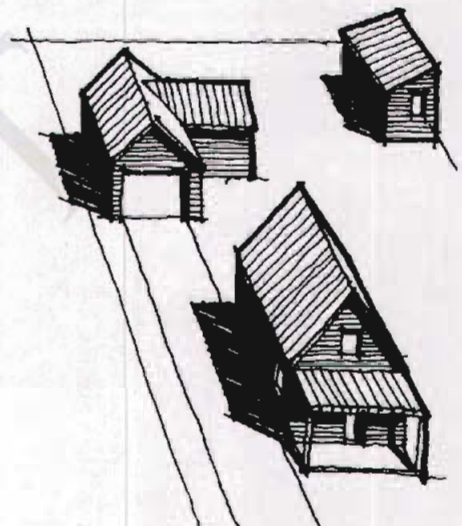

Accessory structures include garages, carriage houses, or sheds. Traditionally these structures were important elements of the residential site.

A variety of roof forms were historically used for garages, including gable, shed and flat roofs.

Preserve historic accessory buildings when feasible.

When treating a historic accessory building, respect its character-defining features such as the primary materials, roof materials, roof form, historic windows, historic doors and architectural details.

In the case of a two-car garage two single door are preferable and present a less blank look to the street.

Historically, garages were sited as a separate structure at the rear of a lot; this pattern should be maintained.



Continuing scale and/or use of early rear garage structures with shared access driveway.



Street facing accessory structure reflecting the house design, and using a pair of side-hinged doors.



Early garage sliding door arrangement with later alterations.

History of Secondary Structures

Studies of secondary structures document a progression from the barn or carriage house to the garage. When the automobile arrived, it was often stored in the barn or carriage house. Later, however, as the automobile became prevalent, the garage took on a building form of its own. According to "Garages in Salt Lake City's Avenues District," many characteristics of the carriage house were adapted to accommodate the car.

For instance, due to fear of its potential flammability, the garage was detached from the house and located a distance from it, usually along an alley, if one existed. Also, various fire resistant materials were used in garage walls, including: vitrified brick, cast concrete, pressed metals or hollow tile. Roof materials included slate, metal, terra-cotta, wood, asphalt and asbestos.

Originally garage doors were similar to those seen customarily on barns and carriage houses: double doors that were side-hinged or that slid horizontally. The use of double doors eventually gave way to a vertically rolling overhead garage door, which was the prototype for the electric garage door. The location of the garage itself moved as owners became less worried about the threat of flammability. During the 1920s, homeowners began to build garages to the side of their house, and by the 1960s the garage was often integral with the house.

Preserving or Rehabilitating Historic Accessory Structures

Primary Materials

Many of the materials that have been used historically in accessory structures are those employed in the construction of primary buildings. The characteristics, use, repair and replacement of these materials are addressed in the preceding chapters. In preserving or rehabilitating accessory structures, it is important that the original materials be preserved to retain the character of the historic structure and its relationship to the house.

Roof Forms and Materials

Most historic accessory structures had gabled or shed roofs, with flat roofs becoming more common from the 1930s. Roofing materials included slate, metal, terra-cotta, wood, asphalt and asbestos. Property owners are encouraged to use period-appropriate roof forms and materials if undertaking more extensive projects, such as converting an accessory structure to a new use. However, because accessory structures are often subordinate to the main house, greater flexibility in their treatment may be appropriate.

9.1 Preserve a historic accessory building when feasible.

- When treating a historic accessory building, respect its character-defining features such as primary materials, roof materials, roof form, historic windows, historic doors and architectural details.
- Avoid moving a historic secondary structure from its original location if possible.



This garage reflects the design of the house in form, details and materials.



Garage & accessory accommodation designed to complement the house.



A traditional design form as garage and accessory space.

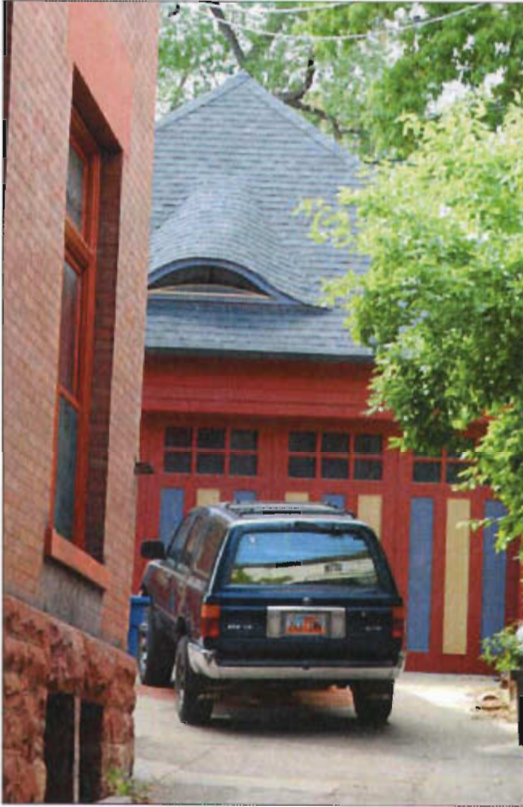

Rear garage designed to complement the house.



Recent rear garage designed to complement the scale and character of the house and setting.

9.2 New accessory buildings should be constructed to be compatible with the primary structure.

- In general, garages should be unobtrusive and not compete visually with the house.
- While the roofline does not have to match the house, it is best if it does not vary significantly.
- Appropriate materials may include horizontal siding, wood shingles, brick, and in some cases stucco.
- In the case of a two-car garage consider using two single doors since they help to retain a sense of human scale and present a less blank look to the street.

9.3 Attaching garages and carports to the primary structure should be avoided.

- Typically before c. 1940 a garage was sited as a separate structure, at the rear of the lot, and this pattern should be maintained where possible.
- The allowance of attached accessory structures is reviewed on a case-by-case basis.

Additional Information

Miller, Lisa. *Garages in Salt Lake City's Avenues Historic District*. Utah: Utah Heritage Foundation.

Preservation Tech Notes 1100: Doors #1: Historic Garage and Carriage Doors: Rehabilitation Solutions. Washington, D.C.: Technical Preservation Services Division, National Park Service, U.S. Department of the Interior.

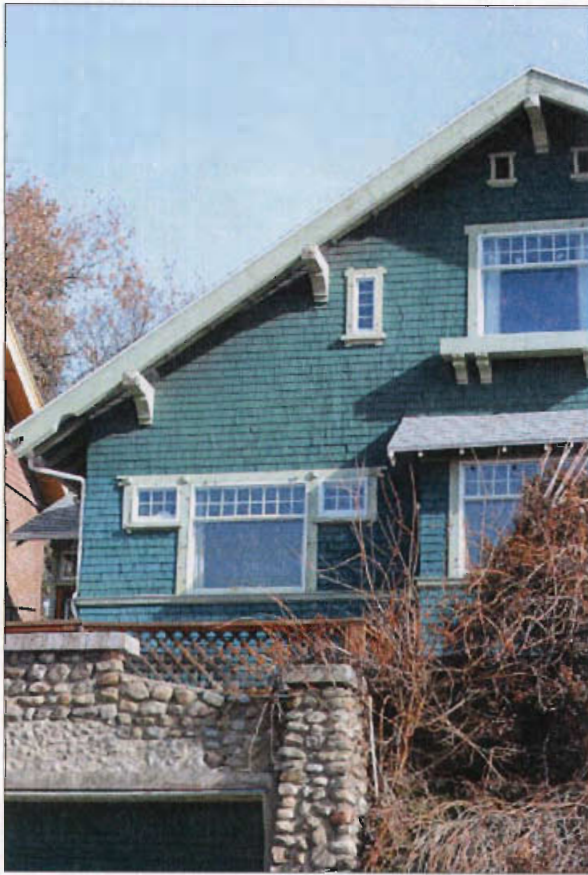

Early street facing 'sunken' garage using river rock facing.



Context sensitive design of accessory accommodation & garage.

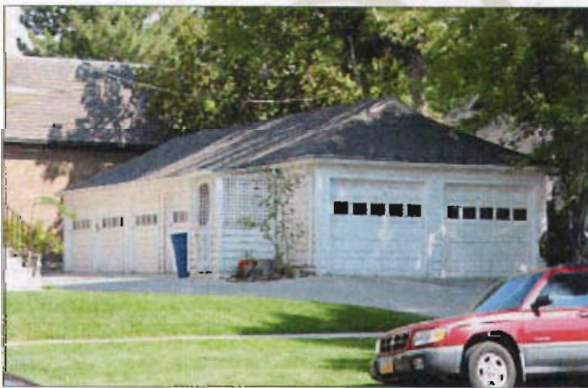

Early multi-car garage with simple form and materials.

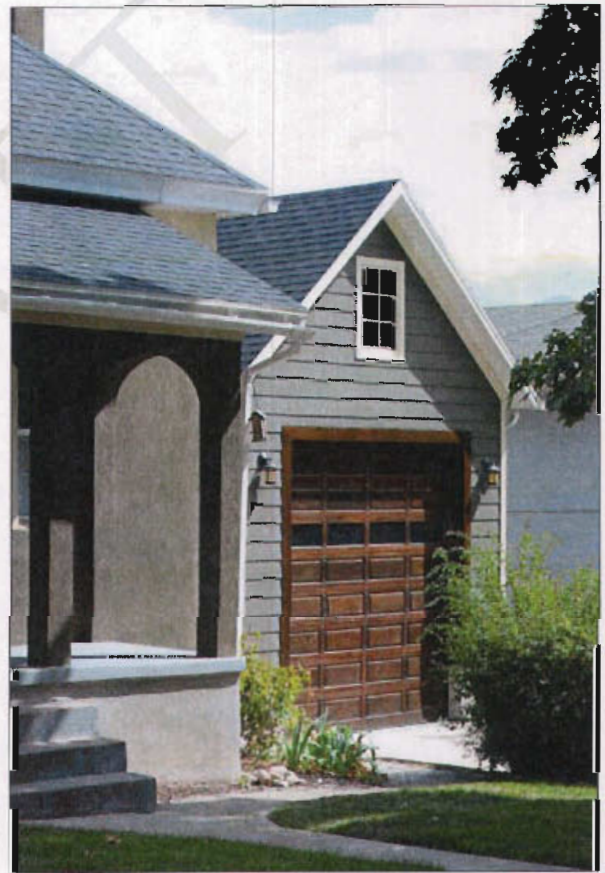

Recent street facing garage addition designed to respect scale & character.

Context and Character

Many historic structures were built during times when there was less knowledge of seismic design and building codes were less restrictive. This may make them vulnerable to damage or destruction in earthquakes. However, today there are methods of reducing the risk of earthquake damage. If carefully planned and executed, these retrofitting techniques can upgrade the safety of the home, while at the same time being sensitive to the historic fabric of the house. By upgrading such features as foundations, floors, ceilings, walls, columns, and roofs, homeowners can improve the resiliency of their historic houses. This will ensure increased personal safety and protection of their investments.

The first step in retrofitting a historic house is to investigate the premises and identify its weak points and features that can be strengthened and reinforced. For an inspection checklist and more information, see “Bracing for the Big One: Seismic Retrofit of Historic Houses,” published by the State of Utah’s State Historic Preservation Office. Alternatively, consult a structural engineer with experience in assessing older buildings.

Design Objective

Retrofitting a historic structure in Salt Lake City to improve its ability to withstand seismic events can be carried out while minimizing negative impacts upon historic features and building materials.

10.1 Seismic retrofitting of a historic building should be designed in a way that has the least impact on the architectural integrity of the building.

- Building materials used in seismic retrofitting should be located on the interior and/or blended with existing architectural features.

CONTEXT AND CHARACTER	10 : 1
DESIGN OBJECTIVE	10 : 1
ADDITIONAL INFORMATION	10 : 2

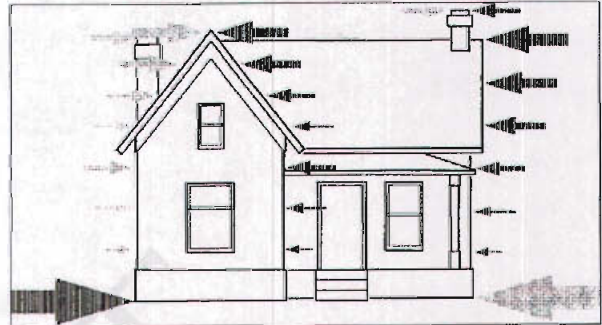

Horizontal forces of earthquakes cause damage to historic structures . (Courtesy of Utah Division of State History, Office of Historic Preservation).



Salt Lake City lies within an area regarded seismically active.



The Stanley F Taylor building, a residence dating to c.1906. was recently seismically upgraded as part of an extensive rehabilitation.

Chapter 10. Seismic Retrofitting

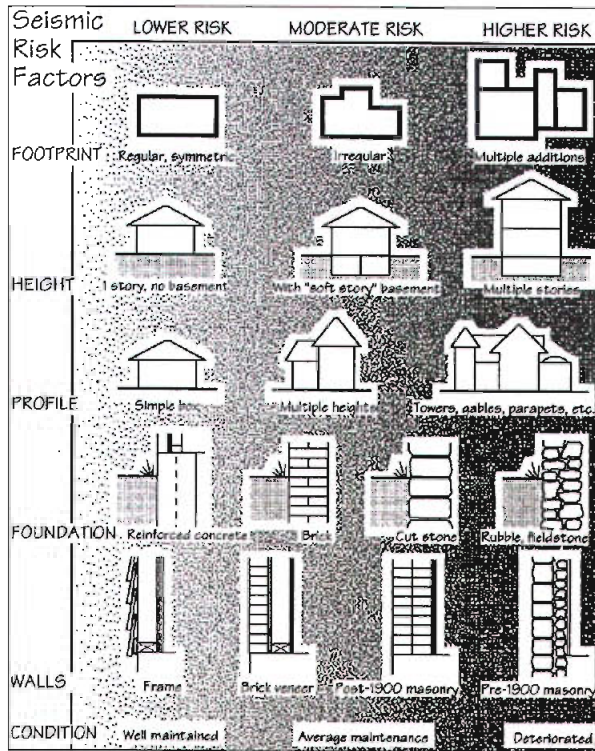

Seismic Risk Factors (Courtesy of Utah Division of State History, Office of Historic Preservation).

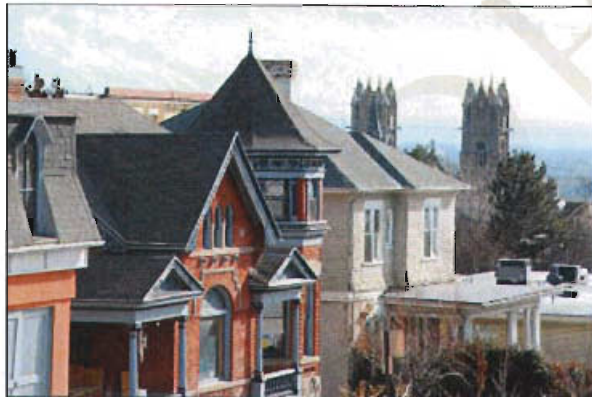

Vista from the Avenues highlighting architectural variety in historic and topographic contexts.

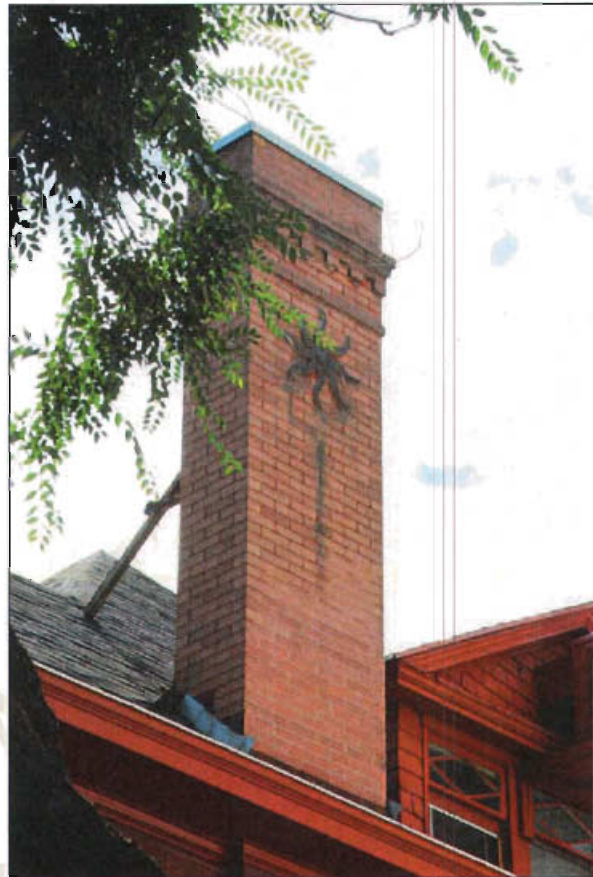

Seismic bracing on one of the many decorative chimney stacks in the city.

Additional Information

Office of Preservation. *Bracing for the Big One: Seismic Retrofit of Historic Houses*. Utah: Utah Division of State History 1993.

"Controlling Disaster: Earthquake-Hazard Reduction for Historic Buildings." *Information Series*, National Trust for Historic Preservation, 1785 Massachusetts Avenue, N.W., Washington D.C. 20036. 1992.

General Design Guidelines



This section discusses design topics that may be associated with all types of projects, including those affecting historic properties as well as other work in local historic districts.

Color

Color is not a matter considered in design review in Salt Lake City. It can however dramatically affect how a building is perceived and its contribution to the character of its setting.

Color schemes vary throughout the historic districts in Salt Lake City. Many are associated with individual building types and styles, while others reflect the tastes of distinct historical periods. Color in itself does not affect the actual form of a building, but it can dramatically affect the perceived scale of a structure, and it can also help to blend a building with its context. Property owners should refer to more detailed discussions of specific color schemes associated with individual architectural styles.

With respect to colors on a historic building, a scheme that reflects the historic style is preferred, although some new color selections can also be compatible. For a newer building in a historic district, a color scheme that complements the historic character of the district should be used. Property owners are particularly encouraged to employ colors that will help establish a sense of visual continuity for the block.

COLOR	11 : 3
ACCESSIBILITY	11 : 4
MECHANICAL EQUIPMENT	11 : 5
LANDSCAPING	11 : 7
SERVICE & PARKING AREAS	11 : 7
ADDITIONAL INFORMATION	11 : 8



Where buildings are set back from the sidewalk, they typically have yards, walks, fences, and plant materials that all contribute to the sense of open space in the community. This character should be maintained as it plays an important role in establishing a context for the historic buildings.

11.1 Color schemes should be simple.

- Using one base color for the building is preferred.
- Muted colors are appropriate for the base color
- Using only one or two accent colors is also encouraged, except where precedent exists for using more than two colors with some architectural styles.
- See the discussion on Architectural Styles.

11.2 Coordinating the entire building in one color scheme is usually more successful than working with a variety of palettes.

- Using the color scheme to establish a sense of overall composition for the building is strongly encouraged.
- A better sense of the coherence of the architectural composition is likely to be achieved.

Accessibility

The Americans with Disabilities Act 1990 mandated that all places of public accommodation are to be accessible to everyone. This includes historic structures that are used for commercial and multi-family uses. While all buildings must comply, alternative measures may be considered when the integrity of a historic resource may be threatened. In most cases, property owners can comply without compromising the integrity of the historic resource.

11.3 These guidelines should not prevent or inhibit compliance with laws on access.

- All new construction should comply completely with the ADA.
- Owners of historic properties should comply to the fullest extent possible, while also preserving the integrity of the character-defining features of their buildings.
- Special provisions for historic buildings exist in the law that allow some alternatives in meeting the ADA standards.

Mechanical Equipment

New technologies in heating, ventilating and telecommunications have introduced mechanical equipment into historic areas where they were not seen traditionally. Satellite dishes and rooftop heating and ventilating equipment are among those that may now intrude upon the visual appearance of historic districts. Wherever feasible, the visual impacts of such systems should be minimized such that one's ability to perceive the historic character of the context is not negatively affected. Locating equipment such that it is screened from public view is the best approach.

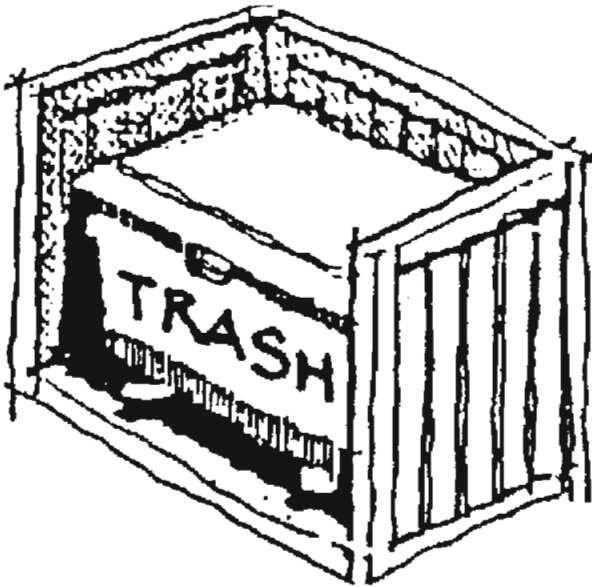

Screen service areas, especially those associated with commercial and multifamily developments, from public view.

11.4 The visual impacts of mechanical equipment as seen from the public way should be minimized.

- Mechanical equipment should be screened from view.
- Ground mounted units should be screened with fences, stone walls, or hedges.
- Where roof top units are visible, provide screening with materials that are compatible with those of the building itself.
- Window air conditioning units should not be located on a primary facade.
- Low-profile mechanical units should be used on rooftops so they will not be visible from the street or alley.
- The visual impacts of utility connections and service boxes should be minimized.
- Smaller satellite dishes should be used and they should be mounted low to the ground, and away from front yards, significant building facades or highly visible roof planes when feasible.
- Muted colors on telecommunications and mechanical equipment should be used to minimize appearance and blend with the background.

11.5 Locate and attach standpipes and other service equipment and pipework such that they do not damage historic facade materials.

- Cutting channels into historic facade materials damages the historic building fabric and should be avoided.
- Keep such equipment and service connections away from the primary facades, wherever feasible.

Landscaping

Native and acclimated plant materials significantly contribute to the sense of a “natural setting” that is part of the heritage in many of the historic districts. Where buildings are set back from the sidewalk, they typically have yards, walks, fences and plant materials that all contribute to the sense of open space in the community. This character should be maintained as it plays an important role in establishing a context for the historic buildings. Preserving established street trees and replacing them when necessary is an example.

11.6 Established native or acclimated plantings on site should be maintained

- Established trees should be preserved on site when feasible.
- Protect established vegetation during construction to avoid damage.
- Replace damaged, aged or diseased trees.
- If street trees must be removed as part of a development, replace them with species of a large enough scale to have a visual impact in the early years of the project; refer to the City’s Urban Forester requirements.

11.7 Indigenous plant materials should be included in new landscape designs.

- Drought-tolerant varieties, that are in character with plantings used historically, are preferred
- Note that the use of gravel and other inorganic surface materials in front yards is prohibited in the Salt Lake City zoning ordinance.
- A list of drought-tolerant plants is available from the Salt Lake City Planning Division.

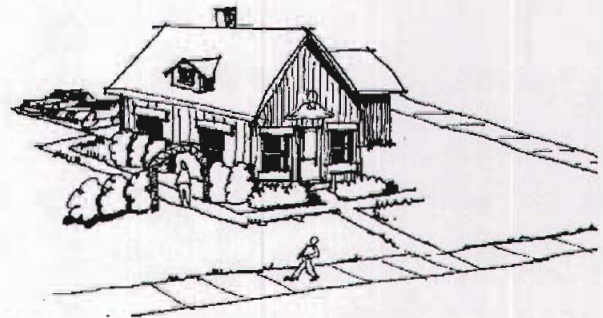

Locate parking areas to the rear of the property, when physical conditions permit.

11.8 The use of traditional site structures is encouraged.

- Constructing retaining walls and fences that are similar in scale, texture and finish to those used historically is appropriate. See also Section 1.0.

Service and Parking Areas

11.9 Minimize the visual impacts of service areas as seen from the street, wherever possible.

- Service areas should be sited away from public view, whenever feasible.
- Service areas, especially those associated with commercial and multifamily developments, should be screened from view, wherever possible. This includes locations for trash containers and loading docks.

11.10 Large parking areas, especially those for commercial and multifamily uses, should not be visually obtrusive.

- Locate parking areas to the rear of the property, when physical conditions permit.
- An alley should serve as the primary access to parking, whenever possible.
- Parking should not be located in the front yard.

11.11 Large expanses of parking should be avoided.

- Divide large parking lots with planting areas.
- In the context of the character and scale of historic residential areas, large parking areas are those with more than five cars.

11.12 Parking areas should be screened from views from the street.

- Automobile headlight illumination from parking areas should be screened from adjacent lots and the street.
- Fences, walls, and plantings, or a combination of these, should be used to screen parking.

Additional Information

Moss, Roger W. and Gail Caskey Winkler. *Victorian Exterior Decoration, How to Paint Your Nineteenth-Century American House Historically*. New York: Henry Holt and Co., 1987.

Schwin III, Lawrence. *Old House Colors-An Expert's Guide to Painting Your Old (Or Not So Old) House*. New York: Sterling Publishing Co., Inc., 1990.

Alderson, Caroline. *Re-creating a 19th Century Paint Palette*, *APT Vol. XVI No. 1*, pg. 47-56. 1984.

Bock, Gordon. *Colorful Issues in Choosing Exterior Paint*, *Old-House Journal*, pg. 50-55. July/August 1996.

Design Guidelines for New Construction in Historic Districts



DRAFT

Cover page image: This house, constructed in 1994, blends in well with the traditional Avenues streetscape because of the fenestration pattern, the roofline and the materials. In addition, the porch compliments the design of the house and serves as an important transitional element between the house and the street.

Chapter 12. New Construction in Historic Districts

These guidelines apply to the design of new principal buildings in locally-designated historic districts. They apply in addition to specific district guidelines provided in chapters that follow later in the book.

Creative solutions that are compatible with the desired character of a historic neighborhood are strongly encouraged, while designs that seek to contrast with the existing context, simply for the sake of being different, are discouraged. This guidance will help protect the established character of each neighborhood, while also allowing new, compatible design.

Designing a building to fit within a historic district requires careful thought. First, it is important to realize that, while a historic district conveys a certain sense of time and place associated with its history, it also remains dynamic, with alterations to existing structures and construction of new buildings occurring over time.

Designating a district does not freeze it in time. It does ensure that, when new building does occur, it will be in a manner that reinforces the basic visual characteristics of the area. This does not mean, however, that new buildings should look old. In fact, imitating historic styles found in a historic district is generally discouraged; historians prefer to be able to “read” the evolution of the street, discerning the apparent age of each building by its style and method of construction. They do so by interpreting the age of a building, placing its style in relative chronological order. When a new building is designed to mimic a historic style, this ability to interpret the history of the street is confused or obscured.

DISTRICT STREET PATTERNS	12 : 4
BUILDING ORIENTATION	12 : 6
MASS & SCALE	12 : 6
BUILDING HEIGHT	12 : 7
BUILDING WIDTH	12 : 8
BUILDING FORM	12 : 8
PROPORTION OF FACADE ELEMENTS	12 : 9
‘SOLID TO VOID’ RATIO	12 : 9
RHYTHM & SPACING	
WINDOWS & DOORS	12 : 10
MATERIALS	12 : 10
ARCHITECTURAL CHARACTER	12 : 11
WINDOWS	12 : 12

These design guidelines apply to all new construction in historic districts. In addition, guidelines in the General section may apply, as well as relevant guidelines in the specific historic district.

Chapter 12. New Construction in Historic Districts

Rather than imitating older buildings, a new design should relate to the fundamental characteristics of the district while also conveying the stylistic trends of today. It may do so by drawing upon basic ways of building that make up a part of the character of an individual historic district. Such features upon which to draw would include the way in which a building is located on its site, the manner in which it relates to the street and its basic mass, form and materials. When these design variables are arranged in a new building to be similar to those seen traditionally in the area, visual compatibility results.

These basic design relationships are more fundamental than the details of individual architectural styles. It is possible, therefore, to be compatible with the historic context of the district, while also creating a design that is distinguishable as being newer than the historic buildings of the area.

Some people may be confused about this concept; for many, the initial assumption is that any new building in the historic district should appear to be old. On the contrary, the design standards that follow encourage new buildings that can be distinguished as being of their own time. At the same time, they do promote new building designs that would relate to the more fundamental similarities of the historic district.

Some of the more fundamental design features that would help a building relate to its context in any historic district in the city are described in the section that follows. More specific concerns about the unique character of each of the local historic districts follow in separate chapters. These are features that should be considered when one is planning new construction in that historic district.

District Street Patterns

Historic settlement patterns evident in street and alley plans often contribute to the distinct character of a historic district and therefore they should be preserved. The details of street layouts may vary for each district and even for sub-areas within an individual district; these are nonetheless very important features that should be respected. These street plans influence the manner in which primary structures are sited, while they also shape the manner in which secondary structures and landscape features may occur on the site.

12.1 When designing a new building, the historic settlement patterns of the district or context should be respected.

- New buildings should be arranged on their sites in ways similar to historic buildings in the area.
- This includes consideration of building setbacks, orientation and open space, all of which are addressed in more detail in the individual district standards.

12.2 The historic district's street plan should be preserved.

- Most historic parts of the city developed in traditional grid patterns, with the exception of Capitol Hill.
- In Capitol Hill the street system initially followed the steep topography and later a grid system was overlaid with little regard for the slope.
- Historic street patterns should be maintained. See specific district guidelines for more detail
- The overall shape of a building can influence one's ability to interpret the town grid. Oddly shaped structures, as opposed to linear forms, would diminish one's perception of the grid, for example.
- In a similar manner, buildings that are sited at eccentric angles could also weaken the perception of the grid, even if the building itself is rectilinear in shape.
- Closing streets or alleys and aggregating lots into larger properties would also diminish the perception of the grid.

Building Orientation

Traditionally, a typical building had its primary entrances oriented to the street. This helped establish a “pedestrian-friendly” quality, which encouraged walking. In most cases, similar entry ways were evenly spaced along a block, creating a rhythm that also contributed to the sense of visual continuity for a neighborhood. This characteristic should be maintained where it exists. Locating the entrance of a new building in a manner that is similar to those seen traditionally is a means of doing so. A front porch is often a characteristic element which reinforces this common orientation, as well as helping to retain a sense of human scale.

12.3 The front of a primary structure should orient to the street.

- The building should be oriented parallel to the lot lines, maintaining the traditional grid pattern of the block.
- An exception is where early developments have introduced curvilinear streets, like Capitol Hill.

Mass and Scale

The mass and scale of a building is also an important design issue in a historic district. The traditional scale of single-family houses dominates many of the neighborhoods, and this similarity of scale also enhances the pedestrian-friendly character of many streets. Often, earlier buildings were smaller than typical more recent houses; nonetheless, a new building should, to the greatest extent possible, maintain this established scale. While new buildings and additions are anticipated that may be larger than many of the earlier structures, new construction should not be so dramatically greater in scale than the established context such that the visual continuity of the historic district would be compromised.

12.4 A new building should be designed to reinforce a sense of human scale.

- A new building may convey a sense of human scale by employing techniques such as these:
 - Using building materials that are of traditional dimensions.
 - Providing a one-story porch that is similar to that seen traditionally
 - Using a building mass that is similar in size to those seen traditionally.
 - Using a solid-to-void ratio that is similar to that seen traditionally and using window openings that are similar in size to those seen traditionally.

12.5 A new building should appear similar in scale to the scale that is established in the block.

- Subdivide larger masses into smaller “modules” that are similar in size to buildings seen traditionally, wherever possible.

12.6 A front facade should be similar in scale to those seen traditionally in the block.

- The front facade should include a one-story element, such as a porch.
- The primary plane of the front facade should not appear taller than those of typical historic structures in the block.
- A single wall plane should not exceed the typical maximum facade width in the district.

Building Height

A similarity in building heights is also an important factor that contributes to the visual continuity of an individual district. In this context a new building should not overwhelm historic structures in terms of building height. Rather, it should be within the range of heights found historically in the vicinity. Similarities in heights among prominent building features, such as porches and cornices, are equally important. These features often appear to align along the block and contribute to the sense of visual rhythm and continuity.

12.7 Building heights should appear similar to those found historically in the district.

12.8 The back side of a building may be taller than the established norm if the change in scale will not be perceived from the public way.

Building Width

In many of the districts, people constructed buildings that were similar in width to nearby structures. This helped to establish a relatively uniform scale for the neighborhood and, when these buildings were evenly spaced along a block, a sense of rhythm resulted. In such a case, the perceived width of a new building should appear similar in size to that of historic buildings in the neighborhood in order to help maintain this sense of visual continuity. For example, if a new building would be wider than those seen historically, it should be divided into modules that appear similar in width to traditional buildings.

12.9 A new building should appear similar in width to that established by nearby historic buildings.

- If a building would be wider overall than structures seen historically, the facade should be divided into subordinate planes that are similar in width to those of the context.

Building Form

In most districts, a similarity of building forms also contributes to a sense of visual continuity, while there may be great variety inherent in the architectural styles and composition. In order to maintain this sense of visual continuity, a new building should have basic roof and building forms that are similar to those seen traditionally. Overall facade proportions also should be in harmony with the context.

12.10 Building forms should be similar to those seen traditionally on the block.

- Simple rectangular solids are typically appropriate.

12.11 Roof forms should be similar to those seen traditionally in the block.

- Visually, the roof is the single most important element in an overall building form.
- Gable and hip roofs are appropriate for primary roof forms in most residential areas.
- Roof pitches should be 6:12 or greater.
- Flat roofs should be used only in areas where it is appropriate to the context. They are appropriate for multiple unit apartment buildings and duplexes.
- In commercial areas, a wider variety of roof forms may be appropriate for residential uses.

Proportion of Building Facade Elements

12.12 Overall facade proportions should be designed to be similar to those of historic buildings in the neighborhood.

- The “overall proportion” is the ratio of the width to height of the building, especially the front facade.
- See the discussions of individual districts and of typical historic building styles for more details about facade proportions.

Solid to Void Ratio.

In most historic residential districts, a typical building appeared to be a rectangular solid, with small holes “punched” in the walls for windows and doors. Most buildings had relatively similar amounts of glass, resulting in often fairly uniform solid to void ratio. This ratio on a new building, the amount of facade that is devoted to wall surface, as compared to that developed as openings, (known as the ‘solid to void ratio’) should be similar to that of historic buildings within the neighborhood.

12.13 The ratio of wall-to-window (solid to void) should be similar to that found on historic structures in the district.

- Large surfaces of glass are usually inappropriate in residential structures.
- Divide large glass surfaces into smaller windows.

Rhythm and Spacing of Windows and Doors

The manner in which openings are distributed across a facade, their grouping or individual placement, can also be an important feature in a district. When similar distribution patterns occur among buildings in a block, a sense of visual continuity also results. When such characteristics occur, this sense of similarity should be preserved.

12.14 The proportions of window and door openings should appear to be similar to those of historic buildings in the area.

- This is an important design criterion because these details strongly influence the compatibility of a building within its context
- Large expanses of glass, either vertical or horizontal, are generally inappropriate on new buildings in the historic districts.

Materials

12.15 Use building materials that contribute to the traditional sense of scale of the block.

- This will help to reinforce the sense of visual continuity in the district.

12.16 New materials that are similar in character to traditional materials may be acceptable with appropriate detailing.

- Alternative materials should appear similar in scale, proportion, texture and finish to those used historically.
- They should also have a proven durability in similar locations in this climate.

Architectural Character

12.17 Building components should be similar in size and shape to those found historically along the street.

- These include windows, doors, and porches.

12.18 Where they are to be used, ornamental elements, such as brackets and porches, should be in scale with similar historic features.

- Thin, fake brackets and strap work applied to the surface of a building are inappropriate uses of these traditional details.

12.19 Contemporary interpretations of traditional details are encouraged.

- New designs for window moldings and door surrounds, for example, can provide visual interest while helping to convey the fact that the building is new.
- Contemporary details for porch railings and columns are other examples.
- New soffit details and dormer designs also could be used to create interest while expressing a new, compatible style.

12.20 The imitation of older historic styles is discouraged.

- One should not replicate historic styles, because this blurs the distinction between old and new buildings, as well as making it more difficult to interpret the architectural evolution of the district.
- Interpretations of historic styles may be appropriate if they are subtly distinguishable as new.

Windows

12.21 Windows with vertical emphasis are encouraged.

- A general rule is that the height of the window should be twice the dimension of the width in most residential contexts.
- Certain styles and contexts, e.g. the bungalow form, will be an exception to this circumstance.
- See also the discussions of the character of the relevant historic district and architectural styles.

12.22 Windows and doors should be framed in materials that appear similar in scale, proportion and character to those used traditionally in the neighborhood.

- Double-hung windows with traditional depth and trim are preferred in most districts.
- See also the rehabilitation section on windows as well as the discussions of specific historic districts and relevant architectural styles.

12.23 Windows should be simple in shape.

- Odd window shapes, such as octagons, circles, diamonds, etc. are discouraged.

Historic Districts



Introduction

The guidelines that follow apply to five locally designated residential historic districts in Salt Lake City: the Avenues, Capitol Hill, Central City, South Temple and University. The purpose of this section is to highlight the character of each district, as well as to offer guidelines that address issues and trends unique to each historic district.

These guidelines are meant to preserve the historic character of each district, while accommodating the incremental evolution of the district through sensitive change. Some of the guidelines presented may repeat topics covered in other sections of the document, but have been reiterated here in order to emphasize their applicability and importance to the relevant district.

Each historic district section has five components:

- a developmental history,
- a description of development trends,
- a statement of goals for the district,
- a description of design character, and
- the design guidelines.

Each district has its own distinct character, which is due in part to factors such as topography and the individual pattern of development. The developmental history for each district explains its evolution. This information, along with the summary of development trends, statement of goals and description of design character, provides an orientation to the context for property owners. The design guidelines that then follow provide special design principles that apply to the specific context.

Design Guidelines for The Avenues District



The Avenues Historic District

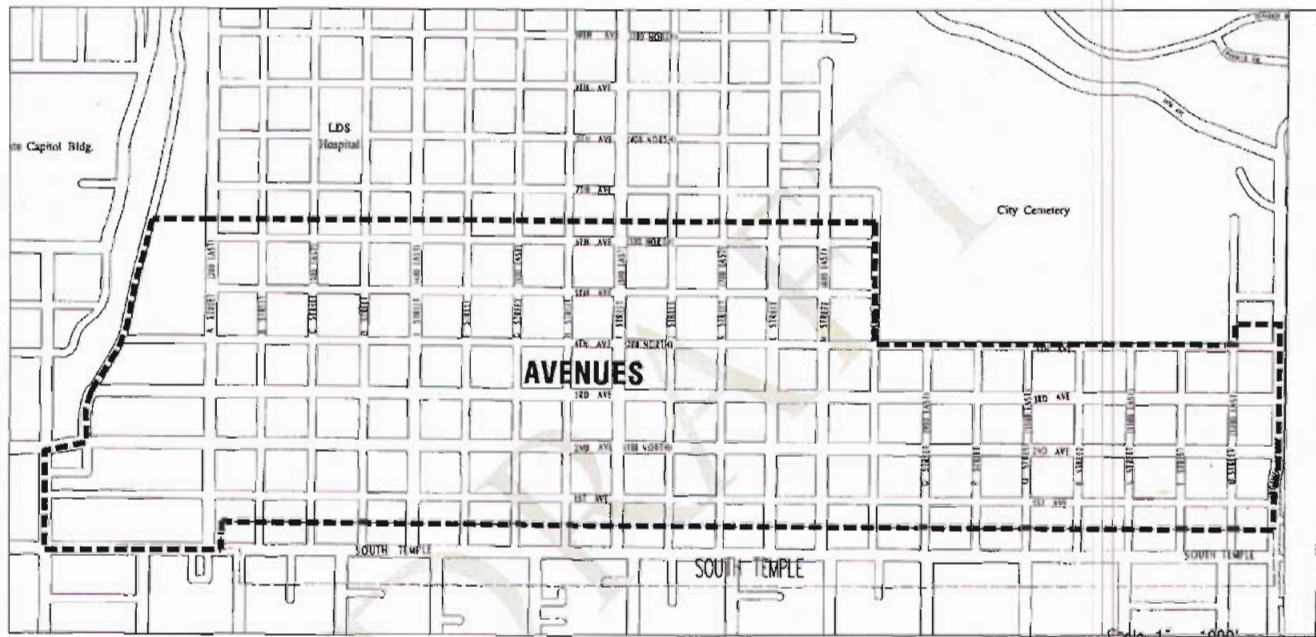

The Avenues Historic District

Not to scale

Cover page image: Elmer Romney's birthday party. In the background, Queen Anne details add interest to a cottage typical of the Avenues.

Historic Architectural Character

The Avenues is Salt Lake City's largest locally-designated historic district, and the one best-known for the preservation efforts undertaken by its property owners. The fine views of the valley, the proximity to downtown and the long-standing diversity of both its architecture and population make the Avenues a desirable place to live.

The appearance of this district is characterized by the predominantly residential use of the buildings, by the variety of styles exhibited, and by the unity of the streetscape. Although platted in the 1850s, with development occurring in the 1870s, the neighborhood did not begin to grow until about 1880, when the difficulty of bringing water up the steep topography was alleviated by diverting water from City Creek Canyon along Sixth Avenue.

The subsequent growth of the Avenues corresponded both with the emergence of Salt Lake City as a regional center, and the variety of architectural styles popular in the United States during the last half of the nineteenth century. By 1889 most of the residents were middle- or upper-middle class professionals and trades people. Some hired architects to design their homes, but the majority relied on building firms who used pattern books and constructed small scale developments of three or four houses using repetitious designs. Although several pre-1880 homes exist, most of the buildings in the district date from the fifty year period between 1880 and 1930. They include many variants of the Victorian style, as well as bungalows.

HISTORIC ARCHITECTURAL CHARACTER	3
CANYON ROAD AND MEMORY GROVE	8
DEVELOPMENT TRENDS	8
CHARACTERISTICS OF THE AVENUES	9
CHARACTERISTICS OF CANYON ROAD AND MEMORY GROVE	9
GOALS FOR THE DISTRICT	9
STREETSCAPE FEATURES	10
PARK STRIPS AND STREET TREES	10
WALKWAYS	10
SITE DESIGN FEATURES	11
FRONT SETBACK	11
SIDE SETBACK	11
ACCESSORY STRUCTURES	12
LANDSCAPE DESIGN FEATURES	12
FENCES AND RETAINING WALLS	12
ARCHITECTURAL FEATURES	13
BUILDING FORM	13
BUILDING MATERIALS	14
APPROPRIATENESS OF USE	14



Historic residences, such as the one above, indicate the strong Victorian era influence in the Avenues historic district.

The Avenues Historic District



A two story frame structure of the Victorian era. The porch has been altered.

From its inception the Avenues differed from the rest of the city. First surveyed in the 1850s as Plat D, the Avenues was platted in 56 blocks of 2.5 acres, with each block subdivided into four lots. This deviated from the rest of Salt Lake, which was laid out in ten-acre blocks, with eight lots per block. The smaller lots and narrower streets and sidewalks, coupled with the large scale of many of the houses, made the Avenues appear much denser than other neighborhoods that developed during the same period.

Originally the east-west streets were known as Fruit, Garden, Bluff and Wall (First through Fourth avenues, respectively), and north-south streets were named after various species of trees. By 1885 the east-west streets had become First through Fourth and the north-south streets had been given the alphabetical titles of A through V (V later became Virginia). When the word "street" was changed to "avenue" the area became known as the Avenues.

Prior to 1880, development in the Avenues was confined to two areas. The earliest Avenues residents constructed homes in the 1850s in the portion encompassed by A and N streets and First and Fourth avenues (Fourth Avenue following the wall of the city). In 1860 slaughter yards were moved to the mouth of Dry Canyon in order to take advantage of the water sources of Dry and Red Butte canyons. Men who wanted to live close to work built houses for their families in the eastern portion of the Avenues and present-day Federal Heights — a neighborhood known as "Butcherville."

The availability of water paralleled other civic improvements, most notably the municipal rail transportation. One of the earliest routes in the Avenues was in place by 1875 with mules providing the power. In 1889 an electric rail system was available and within several years trolley lines ran along Third, Sixth and Ninth Avenues. These streets are wider and flatter than others in the neighborhood as a result. Once the necessary infrastructure was constructed, Salt Lake's expanding economy and growing population assured the development of the Avenues.

"Victorian Eclectic," a loose but apt description, was the most popular style used in the first wave of building after about 1885. In the context of the Avenues, as in other neighborhoods throughout the city, the term indicates the "casual and general approach to house design" and not a slavish adherence to a particular style. It also indicates the flexibility this term provides.

While not as numerous, examples of more high-style architecture also can be seen throughout the district, and include such styles as Queen Anne; Shingle; Dutch, Colonial and Classical revival and Italianate. Residential design immediately after the turn of the century consisted primarily of two types, rather than styles, of structures: the bungalow and the box.



The porch of this Victorian era house exhibits turned wood details of the Queen Anne style.

Toward the end of the nineteenth century the numbers of renters in the Avenues increased. Rental properties were typically managed by widows who needed the income after their husbands died, and by builders and development companies, who constructed both apartment buildings and subdivision homes. Often individuals would acquire two or three lots and build houses, then sell them to large real estate corporations. While small-scale rental properties were constructed throughout the entire district, large apartment complexes exist primarily in the southwest quadrant of the Avenues, closest to Temple Square and downtown. Apartment buildings of the historic period were built in a number of styles, such as Classical Revival, Prairie (Caithness), Tudor Revival and Art Moderne.

Churches, schools and small businesses were also located in the Avenues. Other religious denominations also built churches in the Avenues. Members of the Catholic and Presbyterian faiths could worship at the Cathedral of the Madeleine or First Presbyterian Church, respectively, on South Temple, and Episcopalians had the option of St. Mark's Cathedral, or after 1928, St. Paul's.

The Danish Evangelical Lutheran Church was finished in 1911, but was converted into offices in the 1970s. No historic public schools are extant. The previous Rowland Hall-St. Marks private school, now the Chori School of the Cathedral of the Madeleine, is located in the block between First and Second Avenues and A and B Streets. Historic buildings on this campus include four homes, a chapel and a classroom wing. Neighborhood stores also sprang up throughout the Avenues. In general these were one or two story structures with flat roofs and parapet walls.

In the mid-twentieth century, the popularity of the Avenues declined as other subdivisions were constructed. Federal Heights also offered proximity to downtown and the University of Utah but offered more consistently high-end housing. Subdivisions were developed throughout the city; mass -transit and the automobile made living close to the workplace less of a consideration. By the 1960s absentee landowners owned much of the property and the resulting deterioration was obvious. High-density residential zoning resulted in the demolition of many historic properties and the construction of apartment buildings that were inconsistent with the character of the surrounding buildings.

Gradually the Avenues were rediscovered, however, by those interested in historic homes and by those tired of long commuting distances. Low-interest loans provided by the City assisted renovation activity, and the neighborhood was declared a local historic district in 1978. The next year residents successfully petitioned the city to downzone most of the Avenues to a land use designation that is more compatible with its historic character.



Ottinger Hall was constructed in 1900 for the Volunteer Fireman's Association.

The Avenues Historic District

Canyon Road and Memory Grove

The environs of Canyon Road and Memory Grove are divided between the Avenues and the Capitol Hill historic districts. Their dramatic siting at the mouth of City Creek Canyon makes this area unique and geographically isolated. City Creek, the stream that originally ran down the center of the canyon was one of the determining factors in the decision to settle in the Great Salt Lake Valley. William Clayton, one of the first pioneers to arrive in the valley, described the mouth of the City Creek in his journal:

“At the east part [of their camp] there is a considerable creek of clean, cold water descending from the mountains, and just above this place it branches into two forks, one running northwest, the other southwest, and the two nicely surround this place and so well arranged that should a city be built here the water can be turned into every street at pleasure.”

The source of water led to the construction of several mills along the canyon — the first as early as 1847 or 1848. The earliest homes were built in the area in the 1880s, many by prominent leaders of the Church of Jesus Christ of Latter Day Saints. Architecturally the homes are no different than those seen in the Avenues or Capitol Hill, and vernacular, Eastlake, Italianate and other late Victorian styles, Dutch Colonial Revival and bungalows are among the styles represented. The Veteran Volunteer Firemen’s Association building, also known as Ottinger Hall, is an unusual institutional use in the city but is visually compatible with the density of the buildings along Canyon Road.



Memory Grove’s contemplative ambience is a significant feature of this park.

Development Trends

Known for its ongoing preservation efforts, the Avenues District is experiencing continued investment in the area, including renovation, additions to existing structures and infill construction.



The Avenues District is especially characterized by its mature vegetation, which adds a sense of visual richness to the area.

Characteristics of the Avenues Historic District

- Concrete is the common paving material for sidewalks in the Avenues. A few remnants of sandstone sidewalks and stone paving blocks remain, and these should be retained.
- Streets are in a regular grid pattern; blocks are 2.5 acres each.
- Lots and setbacks are uniform.
- Overall development is dense.
- Current commercial uses are scattered throughout the district, and tend to enhance the livability of the district.
- Garages are usually located behind houses; if they exist they are detached. Most are accessed from single-car wide driveways from the street, although a few blocks have alleys with access to rear-yard parking.
- Architectural styles are varied, although setbacks are usually constant.
- Landscaping is mature.



A modest yet handsome vernacular building in the Avenues, Classical detailing frames the door.

Characteristics of Canyon Road and Memory Grove

- The siting of the homes in Canyon Road makes the neighborhood unique. On the east side of the canyon they follow the slope and a dense pattern is created. Also, Canyon Road splits into two streets, forming a promontory.
- The neighborhood has narrow streets; Spencer Court is particularly narrow.
- Many homes do not have garages. With the exception of Spencer Court, garages are not a part of the streetscape.
- Memorials of several varieties - buildings, a chapel, tanks, flagpoles - are placed against the east side of the park. This forms a "presentation" that can be viewed from the road on the west side.
- Memory Grove has a formal landscape pattern; the hillsides do not.

Goals for the District

The design goal for the Avenues District is to preserve its historic scale and unique character, while accommodating compatible new construction. The distinctive design characteristics of individual building types and styles should be preserved here. New construction should be compatible with its historic context while also reflecting current design.

Streetscape Features

Park Strips and Street Trees

Park strips, the bands of grass that lie between the curb and the sidewalk, are found throughout the Avenues District. Often mature trees grow in the park strip. This coupling of planting strips and mature trees lining the streets provides a shaded environment for pedestrian activity. These elements also establish a rhythm along each block and contribute to the sense of its visual continuity. The Avenues District is especially characterized by its mature vegetation, which adds a sense of visual richness to the area.

Walkways

Typically, a “progression” of walking experiences is encountered along the street. This begins with a walkway that leads from the sidewalk to each building entry; this in turn is occasionally punctuated by a series of steps. Dictated by the topography, the walk often slopes, sometimes quite steeply. Because the Avenues was platted on a grid, and many architectural and landscape features appear consistent, this system of walks contributes strongly to the character of the district.

This progression of entry elements is important, and of these, the walkway itself is an extremely significant element. This progression should be preserved.

13.1 The historic materials and position of a sidewalk, usually detached from the curb, and separated by a planting strip should be maintained.

- Historic paving material, such as sandstone sidewalks, where it exists, should be preserved.

13.2 A walk to the primary building entry from the public sidewalk should be provided.

- The walkway should be distinct from any driveway.
- Concrete is the dominant material; however, other materials, including modular pavers, may be appropriate.

13.3 The use of curb cuts in the Avenues District should be minimized.

- In an effort to preserve the character of the sidewalk and the adjoining streetscape, avoid installing new curb cuts, whenever feasible.
- Historically, the use of curb cuts was quite limited.
- New curb cuts will interrupt the continuity of the sidewalks, and will potentially destroy historic paving material where it exists.

Site Design Features

Due to its small, gridiron plan platted on steep slopes, the development patterns of the neighborhood have distinguished the Avenues as an area with smaller blocks and concentrated residential growth.

Front Setback of Primary Structures

Historically, uniform setbacks in the Avenues established a sense of visual continuity, sometimes expressed as an “architectural wall.” Although a variety in setbacks is seen throughout the district, in fact the setback depths lie within a narrow range, and within an individual block, most buildings appear to align. This generally uniform setback alignment should be maintained.

13.4 The front setback of a new structure should be kept in line with the range of setbacks seen historically on the block.

- In general, larger, taller masses should be set back farther from the front than smaller structures.

Side Yard Setback of Primary Structure

In the Avenues, side yards are generally very narrow and in some cases almost nonexistent. This pattern of moderate density was first established during the early development of the neighborhood, when the blocks were subdivided into long, narrow lots. This pattern creates an urban feel. As a result, the narrow end of the house often faced the street, and the side yards were tight.



Complex, asymmetrical forms compose many of the Victorian-era structures in the Avenues.

The Avenues Historic District

13.5 Side yard setbacks of a new structure or an addition should be similar to those seen traditionally in the block.

- Follow the traditional building pattern in order to continue the historic character of the street.
- Consider the visual impact that new construction and additions will have on neighbors alongside yards.
- Consider varying the setback and height of the structure along the side yard to minimize impacts of abrupt changes in scale.

Accessory Structures

Garages in the Avenues District are simple wood or metal structures generally detached and located behind the house. Most are accessed from single-car width driveways from the street, while a few are accessed through a rear alley. New garages in the district should follow these development patterns in terms of location, size, and character.

13.7 Secondary structures should be located and designed in a manner similar to those seen historically in the district.

- Most secondary structures were built along the rear of the lot, accessed by the alley, if one existed. This should be continued.
- Garages, as well as driveways, should not dominate the streetscape; therefore, they should be detached from the main house and located to the rear of the house, if possible.
- Historically, garages and carriage houses in the Avenues were simple wood structures covered with a gabled or hipped roof.
- A new secondary structure should follow historic precedent, in terms of materials and form.



World War I monument in Memory Grove.

Landscape Design Features

Fences and Retaining Walls

In many sections of the Avenues, yards are bounded by retaining walls. Because many yards have natural slopes, retaining walls have always been features of the district. Walls or terraced yards are often used to create level building sites. Historically, these walls were often topped with cast iron fences. The repetition of masonry retaining walls and fences throughout the district lends a sense of continuity and character to the streetscape that should be continued.

Architectural Features

Building Form

Within the Avenues District a range of architectural styles exists, resulting in a variety of building forms. The large number of Victorian-era structures in the area has established a precedence for construction of buildings with irregular forms and a profusion of wall planes and details.

Depending on the style, some are simple rectangles, with details applied; others are more complex, asymmetrical forms composed of several subordinate masses. Other structures, such as the bungalow and box types, consist of simpler shapes. Free-form, domed or angular forms are not part of the building tradition in the district.

13.8 A new buildings should be designed to be similar in scale to what was seen traditionally on the block.

- Historically, most houses in the Avenues appeared to have a height of one, one-and-one-half or two stories.
- Front facades should appear similar in height to those seen historically in the block.
- Taller portions should be set back farther on the lot.
- Story heights should appear similar to those seen historically. Architectural details should convey a sense of the traditional scale of the block.

These design guidelines apply in addition to those in relevant preceding chapters, which may include Rehabilitation Guidelines, Guidelines for New Construction and General Design Guidelines.

Building materials

Historically, masonry and wood building materials characterized the district. Painted clapboard is typical of frame buildings, although stained shingles appear in wall planes of gables and dormers. Brick is most frequently unpainted.

13.9 The primary materials of a building should be similar to those used historically.

- Appropriate building materials include: brick, stucco, and wood.
- Building in brick, in sizes and colors similar to those used historically, is preferred. Jumbo, or oversized brick is inappropriate.
- Using stone, similar to that used historically, also is preferred.
- Using field stone, or veneers applied with the bedding plane in a vertical position, is inappropriate.
- Stucco should appear similar to that used historically.
- Using panelized products in a manner that reveals large panel modules is inappropriate.
- In general, panelized and synthetic materials are inappropriate for primary structures. They may be considered on secondary buildings.

Appropriateness of Use

In some cases, a residential structure in the Avenues may be converted to commercial use. When this occurs, the residential character should be retained, such that the traditional character of the neighborhood is maintained. Site planning and landscaping should also be designed to respect the residential character of the neighborhood.

13.10 When adapting a residence to a new use, the original design character of the building should be preserved.

- When converted to a new use, a house should retain its residential image.

13.11 If the change from residential to another use requires more parking, locate spaces to the rear of the property and provide landscaping as a buffer.

Design Guidelines for the Capitol Hill Historic District

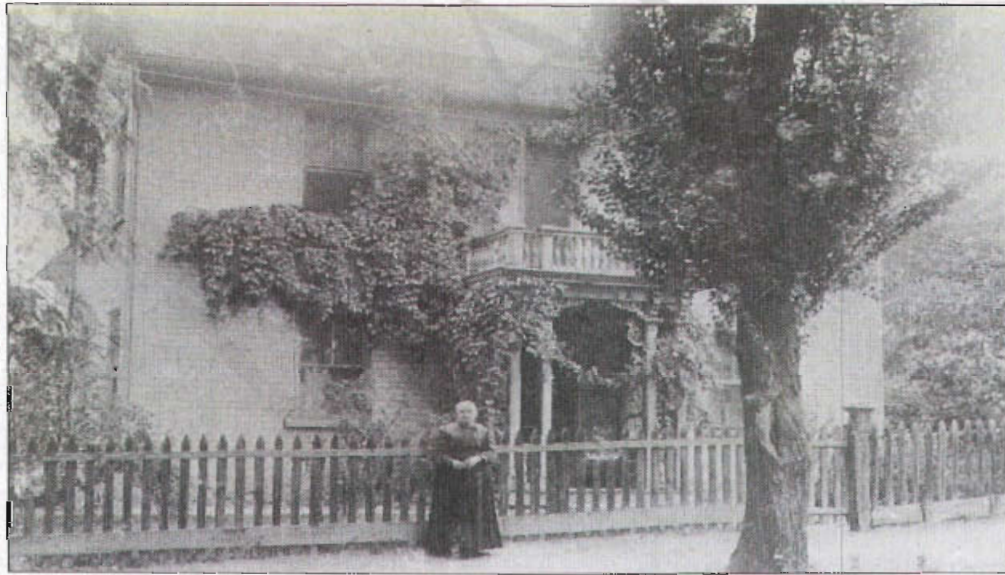

Capitol Hill

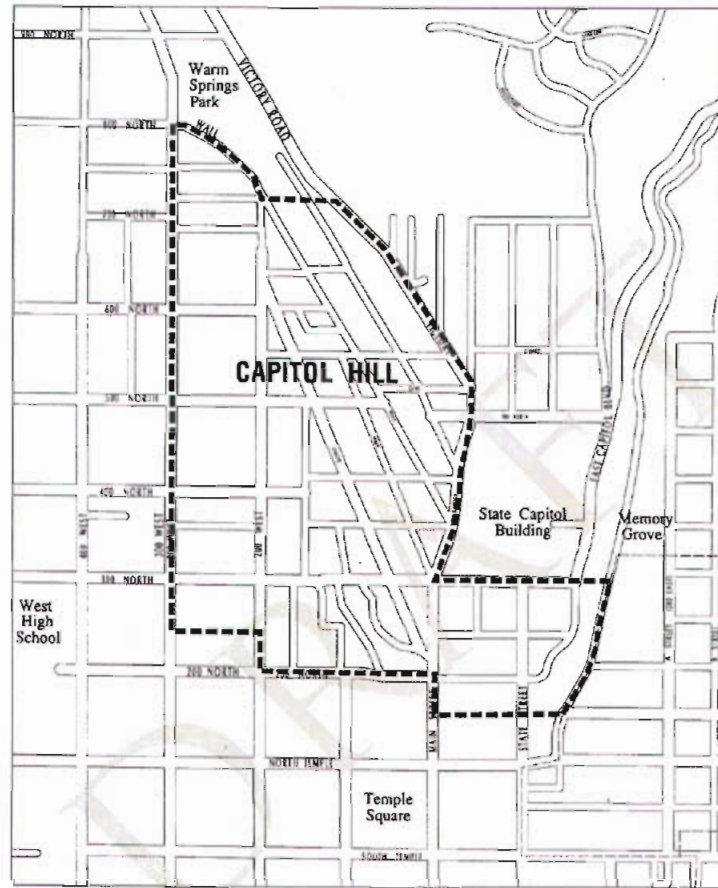

The Capitol Hill Historic District

Scale: 1"=1000'

Cover page image: Sarah Hancok Beesley in front of the home of Ebenezer Beesley on 200 North Street. Italianate posts support a railing with turned balusters for a second floor porch in the background. Also note the wooden picket fence.

Historic Architectural Character

The area encompassed by the Capitol Hill Historic District has always been predominantly residential, but while the land use pattern historically has been consistent, it is the high degree of physical diversity that makes the neighborhood distinct. This is the result of a varying topography, which resulted in construction features such as high foundations and retaining walls, in oddly-shaped blocks, a chaotic street pattern and a haphazard orientation of dwellings to the street; and to the architecture itself, which represents a continuum of styles and building types that span from early settlement to the present. Like the Avenues, over the last twenty years Capitol Hill residents have saved their neighborhood from derelict housing, neighborhood apathy and the perception that the area was an undesirable place to live. Both areas have benefited from widespread down zoning that occurred during the 1980s, and from the commitment of residents to undertake the expense and effort of appropriate renovation.

Despite the poor quality of the soil and the difficulty of obtaining water, Capitol Hill has always been a popular place to live. It was close to Main Street businesses and nearby manufacturing establishments, and yet was removed from the noise and commotion of downtown. The earliest residents were immigrants of limited means from Great Britain and Scandinavia, and even after 1900 the neighborhood continued to attract recent arrivals in similar social and economic circumstances. Because the water supply was erratic and sparse until the 1900s, early settlement occurred only on the lower western and southern reaches of the slope. Prior to about 1890, therefore, the neighborhood had a rural appearance. In fact, one of its most notable characteristics was the proliferation of orchards.

HISTORIC ARCHITECTURAL CHARACTER	CH : 3
DEVELOPMENT TRENDS	CH : 7
CHARACTERISTICS OF CAPITOL HILL	CH : 8
GOALS FOR THE DISTRICT	CH : 8
STREETSCAPE FEATURES	CH : 9
WALKWAYS	CH : 9
STREET PATTERN	CH : 9
SITE DESIGN FEATURES	CH : 9
FRONT SETBACKS	CH : 9
ORIENTATION	CH : 10
LANDSCAPE DESIGN FEATURES	CH : 11
FENCES AND RETAINING WALLS	CH : 11
ARCHITECTURAL FEATURES	CH : 12
BUILDING FORM	CH : 12
BUILDING MATERIALS	CH : 12



This Victorian Eclectic structure exemplifies the visual and architectural richness of buildings in the Capitol Hill district.

Most Capitol Hill residents during this time were craftsmen, and their homes reflected their trade. John Platts, for example, was a stonemason who arrived in the valley from England in 1854. The original block of his home at 364 Quince Street is a one-story fieldstone structure, with a hall-parlor plan. Although simple in massing and materials, Platts' use of sandstone quoins, red rock sills and lintels indicates his pride in his home and that he viewed it as permanent shelter. Similarly, another immigrant, William Asper, arrived in Salt Lake in 1861 and built a house down the street from Platts' at 325 Quince Street. Asper was a carpenter who eventually founded a lumber and planing mill. His house, constructed of brick in 1870, has a profusion of wooden moldings and trim.

By the 1880s water had become available through a series of cast iron mains that extended from City Creek to distributing reservoirs at high points along the foothills. The reservoir that serviced most of Capitol Hill was situated northeast of where the Capitol is now. The accessibility of water made more intense development possible and this, combined with changing architectural styles, altered the appearance of Capitol Hill. The subdivision of lots shifted from the earlier haphazard arrangement to that of a standard rectangular lot, so that the orientation of the houses changed from one of facing the hillside, regardless of the relationship to the streets, to that of being parallel to the street and later, of being oriented to the points of the compass even if the street ran at a diagonal.

Capitol Hill was becoming an increasingly fashionable place to live. Although it remained an enclave of members of the Church of Jesus Christ longer than other Salt Lake neighborhoods, it began to change as the city's population accommodated the influx of non-Mormons during the last two decades of the nineteenth century. The families of men in mining, Denver and Rio Grande Western Railroad workers, and the trades associated with the new industries of the telegraph and the telephone found Capitol Hill as appealing as their neighbors. In an effort to create a stylish image, street names on the west slope were changed from "Bird", "Cross" and "Locust" to those of names of fruits, and this "sub-neighborhood" became known as "the Marmalade District."

The designs of residential architecture shifted from the simplicity and balance of classical styles, exhibited on many of the most modest pioneer dwellings in the district, to the exuberance of the late Victorian era. These newer residents used many Victorian styles, but Queen Anne variants and the ubiquitous Victorian Eclectic prevail in the older sections of Capitol Hill. Some owners remodeled homes that were built during the earlier years of settlement, updating them with elaborate porches or bay windows.



Decorative shingles in the gable, turned posts on the porch and the interlocking brick bay of this house exhibit the high degree of craftsmanship and attention to detail that mark many houses in the neighborhood.

Another neighborhood within the district, known as "Arsenal Hill," developed later than the Marmalade district and the lower slopes. It consists of the upper portion of the south slope, and it did not take on its current layout and appearance until the 1890s. This area takes its name from the fact that the city arsenal was located here. When forty tons of blasting powder accidentally exploded there in 1876 the city ceased to operate the facility, and eventually the large amount of land formerly used for the arsenal became available for building. By this time Salt Lake was undergoing a period of rapid urbanization and prosperity. This, combined with the fine views and close location of downtown, made Arsenal Hill appealing to residents who could afford high style, architect-designed houses.

The completion of the State Capitol building added to the neighborhood's desirability. Its extensive grounds and the imposing structure at the top of the hill spurred new residential construction to the south and the west. Today, Arsenal Hill contains the only large historic apartment buildings in the district. Apartments such as the Kensington at 180 North Main (1906) and the Kestler at 264 and 268 North State (1913 - 1915) are similar to others built during the "apartment boom" that occurred between 1900 and 1930.

After World War II, and the ensuing exodus to the suburbs, the housing stock and overall atmosphere of Capitol Hill began to decline. The neighborhood was too eclectic and too old to compete with the postwar attitude that valued new goods and conformity. By the 1960s the area had a reputation of housing unstable residents with questionable backgrounds. Architecturally, Capitol Hill fell to its nadir with the construction of Zion's Summit, which was built in the early 1970s. These high-rise condominiums dwarfed the surrounding structures and have marred the historic ambiance of the Marmalade district. Other modern buildings, particularly apartments, have detracted from the architectural integrity of the area as well. Happily, about this time preservationists and "urban pioneers" began to invest in Capitol Hill by renovating historic homes. The small scale of the neighborhood, its close location to Downtown, and its unique architectural resources — the very qualities that drove residents away earlier — now proved to be its biggest appeal. Today it is a vibrant neighborhood, with many examples of successful sensitive renovation projects.

Development Trends

Known for its ongoing preservation efforts, the Capitol Hill District is experiencing continued investment in the area, including renovation, additions to existing structures and infill construction. A wide range of renovation and new construction projects is therefore anticipated.



A row of Dutch Colonial structures angled with the street provides a distinct character to the streetscape of this block in the Capitol Hill district.

Characteristics of the Capitol Hill Historic District

The following is a summary of key features of the district.

- Capitol Hill has the most uneven street pattern in the city. The streets are narrow and steep. Lot sizes are odd shapes.
- The orientation of the buildings to the streets is somewhat varied, as some structures face directly and other diagonally.
- Some smaller streets have been closed by the city; as a result there are homes in the middle of a block.
- Builders compensated for the steep topography by constructing retaining walls and high foundations, rather than having the architecture of a structure itself address the lot.
- Most of the buildings are residential, with 300 West containing most of the commercial structures in the district.
- Capitol Hill contains some of the oldest extant homes in the state. These can be found on the lower slopes (below Wall Street) and in the Marmalade neighborhood.
- Street landscaping consists of informal plantings; the district's irregular street pattern and demographics has never lent itself to a formal layout, such as the trees along South Temple. Early on, fruit trees predominated; today "volunteer trees" make up the bulk of the trees.

Goals for the District

The design goals for Capitol Hill are to preserve the unique historic character of the district and to ensure that improvements respect the contrasting character of the two subdistricts, which differ in several respects:

- topography
- street pattern
- orientation of houses to the street, and
- size/ ornamentation of housing stock.

Preservation of the key details of high style buildings should be a priority as well. New building should respect the historic scale of construction, which consists of structures no higher than four or five stories, and in many contexts much lower in height.



Retaining walls provide visual interest to the street, and serve as distinct character-defining features. This characteristic should be preserved.

Streetscape Features

Walkways

Typically, a “progression” of walking experiences is encountered along the streets of Capitol Hill. This begins with a walkway that leads from the sidewalk and is occasionally punctuated by a series of steps. Dictated by the topography, the walkway is often sloping, sometimes quite steeply. In most cases, this walk leads to a front entry, which is clearly defined. In sections of the district without a grid street pattern, no system of walks is prevalent. However, this system is found in other parts of Capitol Hill, especially in the Arsenal Hill subdistrict. Where these walks were seen historically, they should be maintained.

Street Pattern

The two subdistricts developed distinctly different street patterns, which provide the district with a high degree of visual diversity. This diversity characterizes the neighborhood, provides clues about the developmental history of the district, and therefore, should be preserved.

13.12 The traditional rectilinear grid pattern of streets found on the western edge of the district should be maintained.

13.13 The angular, irregular street pattern found in the Marmalade portion of the district should be maintained

13.14 A new driveway, as well as any street improvements, should be arranged so that they continue the respective street pattern.



The “Woodruff-Riter-Stewart Home” at 93 East Second North Street is an example of the variety of architectural styles that can be found in the Capitol Hill Historic District.

Site Design Features

Front Setback of Primary Structure

The southern edge of the district (Arsenal Hill):

This area of the Capitol Hill district was settled on a grid pattern similar to that of the Avenues district, with more uniform setbacks and lot patterns.

Marmalade District:

In this area of the district, the orientation of a building to the street varies, depending on the angle of the street itself. This irregular organization developed because many buildings were constructed to the points of the compass rather than at right angles to the street. The result is a wider variety in setback and orientation of buildings to the street.

Because distinct differences in street pattern exist, the setback and orientation of the primary structure to the street should continue to be based on the established character of the subdistrict.

Orientation

Despite the variety of setbacks and the mixture of lot shapes in the district, buildings in Capitol Hill traditionally had their primary entrance oriented to the street. This relationship should be continued.

13.15 The traditional setback and alignment of buildings to the street, as established by traditional street patterns, should be maintained.

- In Arsenal Hill, street patterns and lot lines call for more uniform setback and siting of primary structures.
- Historically, the Marmalade district developed irregular setbacks and lot shapes.
- Many homes were built toward compass points, with the street running at diagonals.
- This positioning, mixed with variations in slope, caused rows of staggered houses, each with limited views of the streetscape.
- Staggered setbacks are appropriate in this part of the district because of the historical development.
- Traditionally, smaller structures were located closer to the street, while larger ones tended to be set back further.

13.16 The side yard setbacks of a new structure, or an addition, should be similar to those seen traditionally in the subdistrict or block.

- The traditional building pattern should be followed in order to continue the historic character of the street.
- Consider the visual impact of new construction and additions on neighboring houses and yards.
- Consider varying the setback and height of the structure along the side yard to reduce scale and impact.

13.17 The front of a primary structure should be oriented to the street.

- The entry should be defined with a porch or portico.

These design guidelines apply in addition to those in relevant preceding chapters, which may include Rehabilitation Guidelines, Guidelines for New Construction and General Design Guidelines.

Landscape Design Features

Fences and Retaining Walls

The steep topography of the entire Capitol Hill district dictates the need for an extensive system of large retaining walls. These retaining walls, which have been used frequently to adjust for changes in slope, vary in texture, length and layout and are often paired with fences and plant materials. As a result, they provide visual interest to the street, and serve as distinct character-defining features. These characteristics should be preserved.



Staggered setbacks in the Marmalade district are due to its diagonal street pattern.

13.18 Original or early retaining walls and fences should be retained wherever possible.

- Historic materials, detailing and finishes should be retained.
- Consider terracing where the gradient is steep to minimize the height of a retaining wall.
- Refer to guidelines and advice on fences in the Site Features chapter.

Architectural Features

Building Form

Within the Capitol Hill district a wide range of architectural styles exists, which yields a variety of building forms. Perhaps what is the most distinctive feature of the Marmalade subdistrict is the profusion of dwellings of simple design and detailing and of modest scale. Although Arsenal Hill has examples of vernacular designs, it also has numerous Queen Anne and two-story box-style buildings.

13.18 A new building should be designed to be similar in scale to those seen historically in the neighborhood.

- In the Marmalade subdistrict, homes tended to be more modest, with heights ranging from one to two stories.
- Throughout Arsenal Hill larger, grander homes reached two-and-half to three stories.
- Front facades should appear similar in height to those seen historically on the block.

13.19 A new building should be designed with a primary form that is similar to those seen historically.

- In most cases, the primary form for the house was a single rectangular volume.
- In some styles, smaller, subordinate masses were then attached to this primary form.
- New buildings should continue this tradition.



This classically-inspired duplex is an example of high style multifamily housing in Salt Lake City. A centrally located porch defines the entrance. This structure was extensively renovated in 1995.

Building Materials

Historically, masonry and wood building materials characterized the district. Brick and rusticated stone were also evident, as was painted clapboard.

13.20 Building materials that are similar to those used historically should be used.

- Appropriate primary building materials include stone, brick, stucco and painted wood.

Design Guidelines for the Central City Historic District



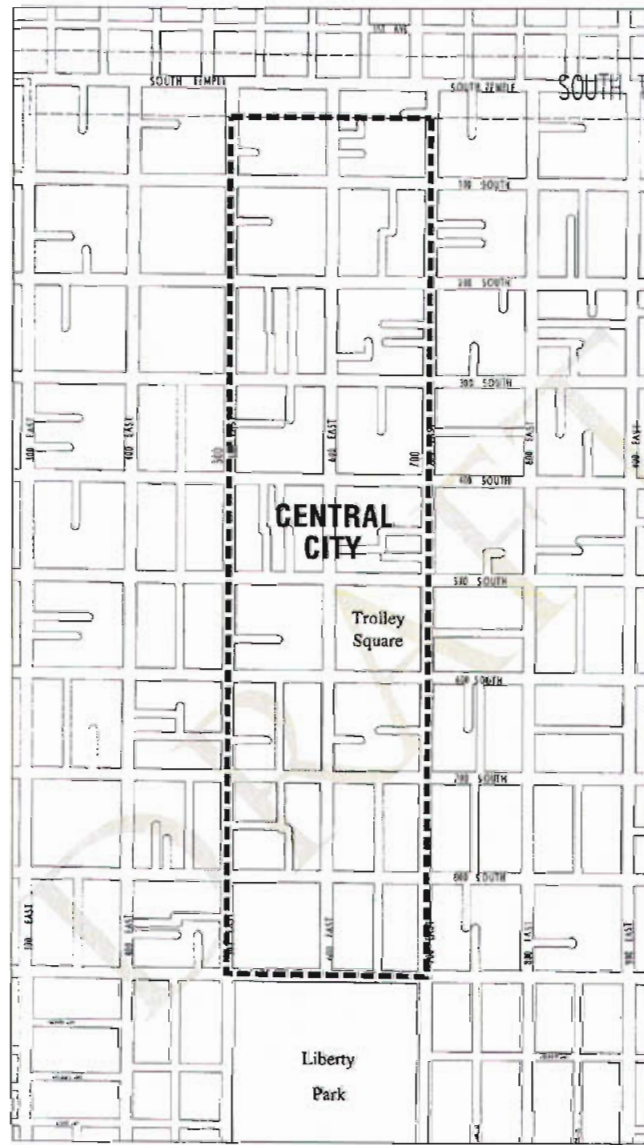

Central City Historic District

Scale: 1"=100'

Cover page image: A 1909 view looking north from 100 South up 700 East.

Historic Architectural Character

Encompassing one of the oldest neighborhoods of the city, the Central City Historic District is part of a larger area, known by the same name that is associated with the original plan of Salt Lake. Out of all of the requirements outlined by Joseph Smith’s “Plat for the City of Zion” only the size of the blocks – ten acres – remains intact, and what was once a village and agricultural landscape now reflects the fact that Central City has the most complex zoning and land-use patterns in Salt Lake. Although a few adobe vernacular homes still exist, the commercial development, including fast-food restaurants, office buildings and retail centers, belies its early history. Despite recent, incompatible intrusions, Central City still has the most eclectic mix of historic architecture in Salt Lake, including several unique examples of a variety of building types.

Central City began to lose its early appearance and social structure with the building of the railroad and later the opening of the Bingham copper mine. These developments created a demand for unskilled workers who needed affordable places to live. In addition, Central City’s proximity to the expanding downtown business district and nearby manufacturing and processing plants attracted clerks, laborers and craftspeople, so that early on it became known as a neighborhood for the working lower- and middle-class. With the exception of imposing residences at the north end of the district, Central City never became a fashionable neighborhood and the population was unstable. As the Central/Southern area survey states, “Workers moved on to other jobs, to other towns; more prosperous families were attracted to the benches, where the air was cleaner, and to new subdivisions.”

HISTORIC ARCHITECTURAL CHARACTER	CC : 3
DEVELOPMENT TRENDS	CC : 6
CHARACTERISTICS OF CENTRAL CITY	CC : 7
GOALS FOR THE DISTRICT	CC : 7
STREETSCAPE FEATURES	CC : 8
STREET PATTERN	CC : 8
LANDSCAPE FEATURES	
- FENCES	CC : 8
SITE DESIGN FEATURES	CC : 9
FRONT SETBACK	CC : 9
PORCHES	CC : 9
ARCHITECTURAL FEATURES	CC : 10
ADDITIONS / ALTERATIONS	CC : 10
BUILDING MASS	CC : 10
BUILDING SCALE	CC : 11
BUILDING FORM	CC : 11
BUILDING MATERIALS	CC : 11
COMMERCIAL AREA FEATURES	CC : 12

Central City

Given these demographics, rental housing has proliferated and much of the housing stock has always been modest. Thomas Newton was typical of the nineteenth-century Central City resident, as was his house. Newton worked as a clerk and shoemaker for ZCMI and constructed a small, side-gabled house in 1888 at 326 South 700 East. With its side-gabled massing and simple two-over-two windows, this house exhibited the simple forms of early Utah architecture, as well as illustrating how long such forms remained popular. This property was demolished and is now a parking lot.

Central City also has an extensive stock of "Victorian Eclectic" architecture. Several examples can be seen along 600 East between 600 and 800 South. Although not as popular for Central City's small houses, the exuberant Queen Anne style was also used. Victorian styles continued to be built until the turn of the century but were quickly replaced by the bungalow, which by 1915 had become the small house of choice. Because the bungalow was more of a type rather than a style, this architectural form also lent itself well to many variations.

The transient nature of Central City's population encouraged the construction of many rental units, including duplexes, fourplexes and multi-unit apartment buildings. Because of their small size, duplexes took on the style of whatever was popular at the time; and thus late Victorian, Craftsman, and Tudor Revival examples can be found. Apartment buildings, on the other hand, developed as their own form: the walk-up flat type used before 1918, and the "double-loaded corridor" introduced later. Central City also has several apartment types that are very unusual, such as one-story courtyard structures, and the only remaining example of Victorian row housing left in Salt Lake.

Central City was not only home to working-class citizens, and not all of the buildings are unassuming or were built as rentals. Professionals, businessmen and politicians lived in Central City, many residing in the neighborhood for decades. Frederick Albert Hale, a Cornell-educated architect, lived on 600 East from 1905 to 1934. He was one of the state's finest architects, designing for wealthy clients. His work includes the Alta Club, the First Methodist Church and the Salt Lake Public Library (subsequently the Hansen Planetarium and now O. C. Tanner). Several lawyers and executives associated with the mining industry lived in the north end of the district. Politicians included Utah's fourth governor, Simon Bamberger who lived at 623 East 100 South, and more recently, Palmer dePaulis, mayor from 1986 to 1992.

Similarly, not all of the buildings are modest. Mansions include Francis Armstrong's, at 679 East 100 South, and Orange Salisbury's, designed by Frederick Hale, at 574 East 100 South. Within the historic period affluent families built residences as four-squares, or in the Victorian Eclectic and Queen Anne styles.

Almost all of the buildings in Central City constructed before 1945 are residential. Exceptions include the Swedish Baptist Church, constructed in 1913, and the Twelfth Ward Chapel, built in 1939. The Swedish Baptist Church is Craftsman in style, and blends in well with the surrounding homes at 823 South 600 East. The chapel is an unusual example of Art Moderne for this building type, and is located at 630 East 100 South. There are several small grocery stores scattered throughout the district, but the most impressive nonresidential structure is Trolley Square. Built as trolley barns for the Utah Electric and Railway Corporation from 1908 to 1910, the barns were renovated as a shopping and entertainment complex in the early 1970s.

Because of its early layout, large blocks and role as "the inner city," Central City has always been beset by land-use conflicts. The large blocks led to haphazard development as early as 1900 and were subject to incompatible development because of insensitive zoning and an encroaching downtown. Central City has been subject to the problems associated with absentee ownership for decades. Fourth South developed as a commercial corridor after World War II and, with the addition of TRAX, is now a very busy street, with scope for pedestrian friendly improvements.

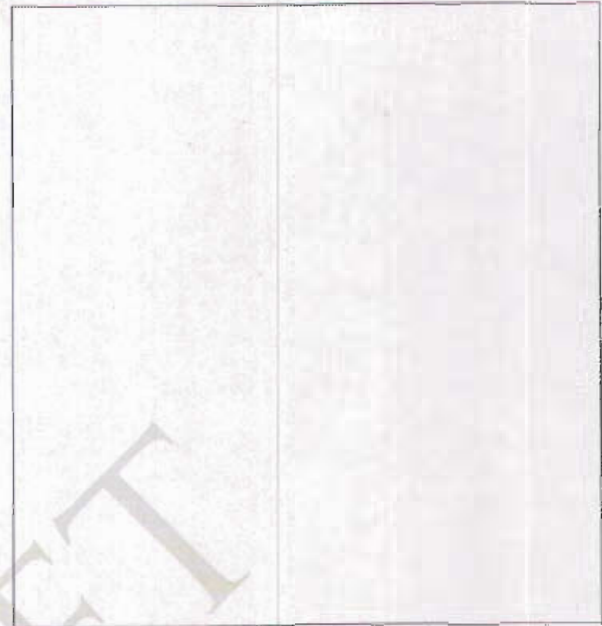

Ma qui id qui cum aperferias alis quo ea di veris apernat omnis quae cullabo rionsequi officio moluptat.



Trolley Square under construction.

The City and residents have, if periodically, made attempts to improve Central City. One effort, still intact, was the creation of “parkings,” or landscaped medians, down several streets, including 600 East, as part of the removal of electrical wires and poles moved from the center of the street to accommodate the new street car system. In response to the deteriorating conditions of many houses because of foreclosures during the Depression, the first neighborhood beautification program was organized in the 1930s. Local resident Sheldon Brewster headed up the campaign to influence people to buy homes in the area and maintain them. In 1932 an organization called “the Central Civic Beautification League” fought an uphill battle to “turn the tide of decay and stultification back.” This group concentrated its efforts on keeping business out of residential areas, soliciting money for structural repair and attempting to instill a sense of community in the neighborhood. Most recently, neighborhood residents have been renovating structures, and petitioned the City to adopt part of Central City as a local historic district. The designation was accomplished in 1991.

Development Trends

The district has experienced a surge of renovation and improvements to properties. Continued investment is expected, particularly in rehabilitation. However, some new infill construction also is anticipated.

Characteristics of the Central City Historic District.

The following is a summary of key features of the neighborhood.

- Large, ten-acre blocks are located north of 600 South.
- Residential, interior block development exists south of 600 South. Streets such as Green, Park and Lowell are several interior streets that are very narrow, from 15' to 25' wide. The lots are typically about 2,500 square feet, setbacks about 10'.
- Garages are set at the rear of the lot and are accessed by alleys.
- Grass medians run the length of the district from Liberty Park to South Temple.
- Architectural styles range from the 1870s to the contemporary. "High-style" examples are generally located north of 400 South. Smaller, more modest homes are located in the southern portion of the district.
- Fourth South is totally commercial, and has no remaining historic structures.
- The center of several of the large blocks north of 400 South are vacant



Many of Central City's yards are bounded by fences.

Goals for the District

The most significant feature of this district is its overall scale and simple character of buildings as a group, as a part of the streetscape. As a result, the primary goal is to preserve the general, modest character of each block as a whole, as seen from the street. Because the overall street character is the greatest concern, more flexibility in other areas, particularly renovation details should be allowed. This goal for preservation should also be considered in the context of related neighborhood goals to attract investment and promote affordability.

Streetscape Features

Street Pattern

The Central City district developed on a rectilinear plan, with spacious blocks intersected by wide streets. Sidewalks are detached and street trees are located in the park strips in many cases. Street widths vary considerably, ranging from a boulevard along 600 East Street to short, narrow alleys and lanes.

13.21 The character and scale of the side streets in the district should be maintained.

- Many side streets, particularly the lanes, have a distinct character and scale that should be preserved.

13.22 Alleys should be maintained where they exist.

- Their modest character should be preserved.

Landscape Features - Fences

Many of Central City's yards are bounded by fences. Historically, materials were wood and metal.

The design guidelines apply in addition to those in relevant preceding chapters, which may include Rehabilitation Guidelines, Guidelines for New Construction and General Design Guidelines.

Site Design Features

Front Setback of Primary Structure

Although a variety in setbacks is seen throughout the district, most buildings within a block appear to align along their front setbacks, within a narrow range of dimensions. Historically, larger buildings in the district, such as apartment buildings, were set back farther away from the street than the single structures. In some cases, small dwellings sit at the edge of the sidewalk, creating a very urban feel. This is particularly evident along Park Street, which has the character of a developed lane or alley. These traditional setbacks should be maintained.

13.24 The established alignment of building fronts in the block should be maintained.

- In general, larger, taller masses should be set back farther from the front than smaller structures.
- In some cases, therefore, a setback that is greater than the median setback may be appropriate.

13.25 The rhythm established by uniform setbacks in the block should be maintained.

- It is particularly important that the traditional spacing pattern be maintained as seen from the street.
- The traditional building pattern should be followed in order to maintain the historic character of the street.
- The visual impact of new construction and additions on neighbors adjoining yards should be considered.
- Varying the height and setback of the structure along the side yard should be considered.



The uniform setback of these vernacular structures provides a sense of alignment and the porches provide a consistent orientation to the street.

Porches

A clear definition of the entry to each building is one of the most significant character-defining elements in the district. In a typical situation, the primary entrance faces the street and is sheltered with a porch.

13.26 Where historic porches exist, they should be preserved.

- They also are strongly encouraged as a feature in new construction.

13.27 The primary entrance to the house should be clearly defined.

- Use a porch, stoop, portico or similar one-story feature to indicate the entry.
- Orienting the entry to the street is preferred.
- Establishing a “progression” of entry elements, including walkway, landscape elements and porch also is encouraged.



Orienting the entry to the street is preferred. Establishing a "progression" of entry elements, including a walkway, landscaped elements and porch also is encouraged.

Architectural Features

Additions/Alterations

13.28 An addition should be designed to be in character with the main building, in terms of its size, scale and appearance.

- This is especially important in portions of the district where buildings are modest in size and scale and have limited architectural detailing.
- Greater flexibility is appropriate, in terms of size of additions, on the northern edge of the district near South Temple Street, where many of the historic buildings are quite large.

Building Mass

13.29 New buildings should appear similar in mass to those that were typical historically in the district.

- If a building would be larger than those seen on the block, the larger masses of the building should be subdivided into smaller "modules" that are similar in size to buildings seen traditionally.
- Orienting the entry to the street is preferred.
- Establishing a "progression" of entry elements, including walkway, landscape elements and porch also is encouraged.

Building Scale

13.30 New buildings should be designed to appear similar in scale to those seen traditionally on the block.

- Historically, most houses appeared to have a height of one, one-and-one half or two stories.
- A new front facade should appear similar in height to those seen historically in the block.
- Taller portions should be set back farther on the lot.
- Story heights should appear similar to those seen historically.
- Also, consider using architectural details to give a sense of the traditional scale of the block.



Use building materials that will appear similar to those used historically.

Building Form

13.31 A new building should be designed to have a form similar to those seen historically.

- In most cases, the primary form of the house was a simple rectangle.
- In some styles, smaller, subordinate masses were then attached to this primary form.

Building Materials

13.32 Primary building materials that will appear similar to those used historically should be used.

- Appropriate building materials include: brick, stucco, and painted wood.
- Substitute materials may be considered under some circumstances.
- See Sections ? and ? and page ??.

Commercial Area Features

While most of the district retains a traditional residential character, some major commercial streets bisect the neighborhood in an east-west direction. These have redeveloped recently with commercial uses in auto-oriented designs and as a result, no historic context exists there.

Franchise facilities appear frequently along the cross streets. Most of these are set back substantially from the street, with large parking areas located in front. Large signs are often mounted on tall poles and landscaping is used sparsely. Curb cuts appear frequently and extensive portions of most sites are paved with hard surfaces. The result is that these areas offer little to pedestrians, in contrast to the pedestrian friendly character of the historic residential streets in the district. When viewed from within the more intact residential portions of the district, these commercial zones are visually disruptive.

The design goal for these commercial areas is to enhance the pedestrian environment and to minimize negative visual impacts as seen from the historic residential portions of the district. It is not the intent to create a "historical" image for buildings in these areas, but simply to apply principles of good urban design that will enhance the visual quality while accepting the "contemporary" character that exists here.

13.33 The visual impacts of automobile parking as seen from the sidewalk should be minimized.

- Landscaped buffer areas should be used to screen and separate the sidewalk from parking and drive lanes within individual commercial sites.

13.34 Service areas should be screened from the residential portions of the historic district.

- Fences, walls and planting materials should be used to screen service areas.
- When feasible, locate service areas away from residential portions of the historic district.

13.35 The visual impacts of signs should be minimized.

- This is particularly important as seen from within the residential portions of the historic district.
- Smaller signs are preferred.
- Monument signs and low pole-mounted signs are appropriate.

13.36 All site lighting should be shielded so that it does not spill over into residential portions of the historic district.

Design Guidelines for the South Temple Historic District

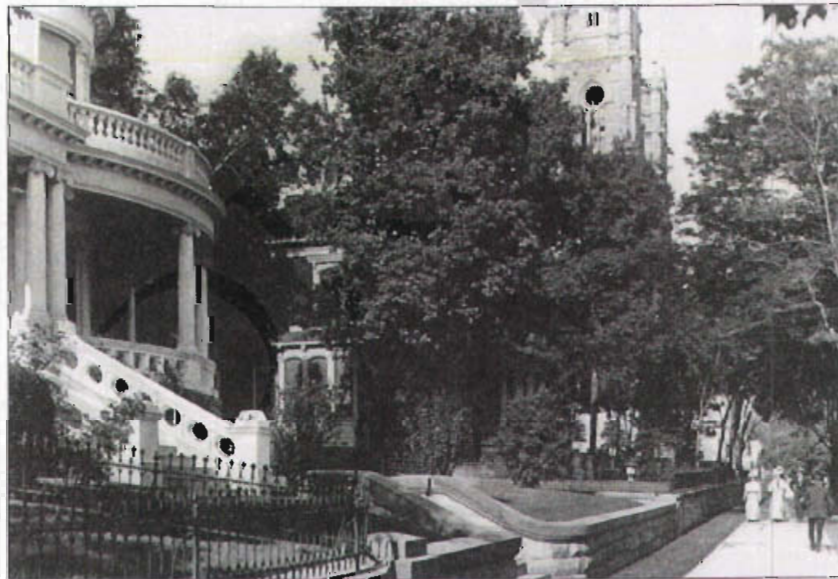

South Temple Historic District

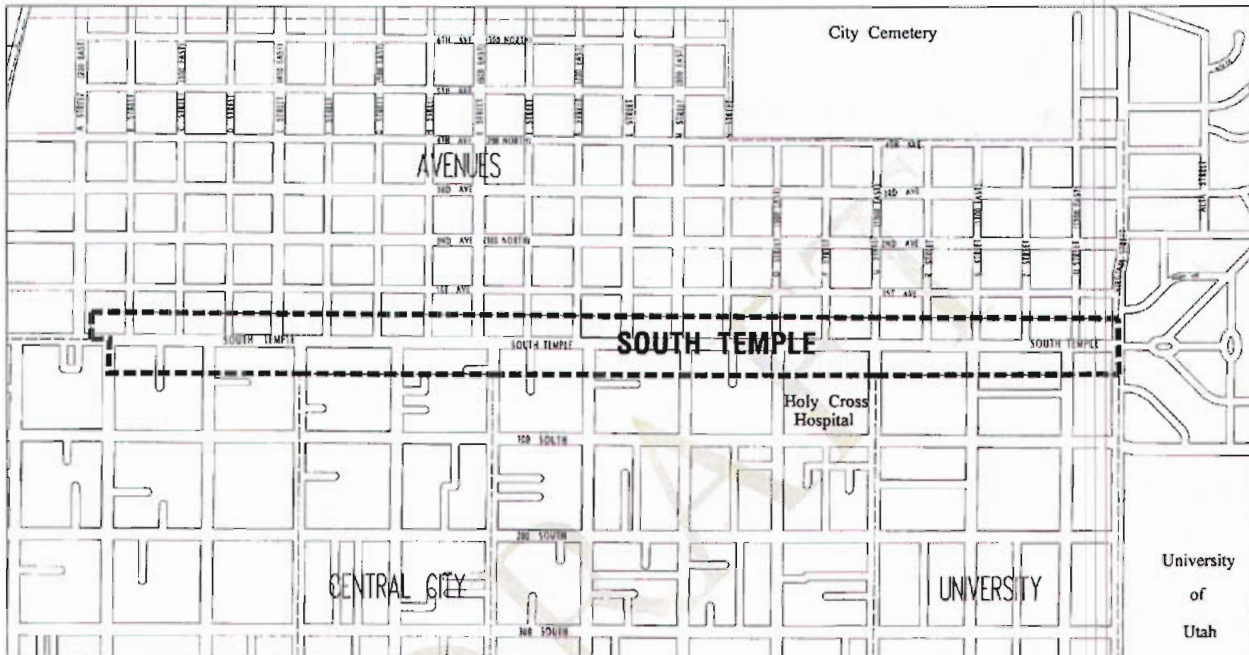

The South Temple Historic District

Scale: NTS

Cover page image: Looking southeast along South Temple from 5th West in 1918: stone retaining walls and cast iron fences define the sidewalk edge. Extensive porch detailing provides a strong sense of orientation to the street.

Historic Architectural Character

South Temple is frequently referred to as Utah's premier residential boulevard, a testament to the transformation of Salt Lake City from an agricultural village to an urban center, one that could support the elegance and grandeur seen in the architecture along this street. Although it was not until around 1900 that South Temple took on the stately appearance most closely aligned with the perception of visitors and residents, South Temple has played an essential role in the development of Salt Lake since the City was founded. It served as a connection between the East Bench and Downtown and provided a delineation between the small lots of the Avenues neighborhood and the larger blocks of Central City. In general, South Temple has attracted people of prominence and prosperity, but within this group residents represented a variety of religious faiths, occupations and backgrounds. People of lesser means, including skilled craftsmen and teachers, have also resided on South Temple. South Temple was not immune to the surge of city-wide apartment construction that occurred from 1902 to 1931.

HISTORIC ARCHITECTURAL CHARACTER	ST: 3
DEVELOPMENT TRENDS	ST: 5
CHARACTERISTICS OF SOUTH TEMPLE	ST: 5
GOALS FOR THE DISTRICT	ST: 6
STREETSCAPE FEATURES	ST: 6
WALKWAYS	ST: 6
SITE DESIGN FEATURES	ST: 7
FRONT SETBACK	ST: 7
SIDE YARD SETBACK	ST: 8
CURB CUTS	ST: 8
SERVICE AREAS	ST: 8
SITING OF ADDITIONS	ST: 8
ARCHITECTURAL FEATURES	ST: 9
PORCHES	ST: 9
ORNAMENTATION	ST: 9
BUILDING AND ROOF MATERIALS	ST: 10
APPROPRIATENESS OF USE	ST: 10

South Temple Historic District

The history of South Temple begins with the founding of Salt Lake City, which was laid out according to Joseph Smith's plan for the City of Zion. It was originally platted as the major east-west axis, but because nothing but open country existed to the east until Fort Douglas was founded in 1862, construction along South Temple during the 1850s was confined to the blocks between 200 East and 400 West. The decision of Brigham Young and other church leaders to build homes on South Temple set an early precedent for the street's residential prominence. Although early church leaders did not anticipate South Temple's eventual role as the home of wealthy miners and the most urbane street in the state, there is no doubt that they intended South Temple to be an important thoroughfare for the religious kingdom of Zion.

The landscape and architecture of South Temple had the same agrarian look — small, adobe homes, orchards, and barnyards — as the rest of the city through the 1860s. Once the railroad brought prosperity and expansion it gradually lost its rural appearance. By the 1890s, South Temple was fulfilling Brigham Young's prediction that it would become the finest street in Zion. The most imposing mansions, those of David Keith, Thomas Kearns, Enos Wall, and Louis Terry represented an influential group of men who had earned great wealth through mining and had no cultural or religious association with the Church of Jesus Christ of Latter Day Saints. Their desire to separate themselves socially could be seen in the establishment of the Alta and the University clubs (the latter demolished in the 1960s) while the construction of the Cathedral of the Madeleine and the First Presbyterian Church announced that other faiths had a permanent stake in the city.

Professional people who were not as wealthy but prominent nonetheless were also building large comfortable homes in the variety of styles popular throughout America. They built four-square boxes, using simple classical capitals on porch columns and Palladian windows, Shingle style houses with complex floor plans and rich surface texture, and Arts and Crafts bungalows. These styles could be seen throughout the city, but South Temple residents built more elaborate versions representing some of the finest work of the state's best-known architects, including Walter Ware, Frederick Albert Hale, C.M. Neuhausen and Richard A. Kletting.

During the 1920s and 1930s building along South Temple consisted primarily of apartment buildings and clubhouses for fraternal and women's organizations, although significant examples of both uses had also been erected in earlier decades. The apartment buildings along South Temple were part of a construction boom of this building type and represented some of the most elegant multifamily structures in the city. The earliest clubhouse still extant on South Temple is the Ladies Literary Club at number 850 East, an outstanding Prairie-style example designed by Ware and Treganza in 1912. Two of the largest buildings constructed during the 1920s included the Masonic Temple and the Elks Buildings, both designed by the firm of Scott and Welch.

Although many handsome structures were built during the 1920s and 1930s South Temple's grandeur began to wane during these years, ultimately resulting in the awkward blend of residential buildings and commercial structures evident today. Wealthy families aged and dispersed, and federal income tax, imposed in 1913, eroded personal fortunes. Most devastating to the street, however, were zoning changes that allowed commercial encroachment and higher residential densities. As land value increased, significant structures were lost.

This problem became acute after World War II, when shifts in style and technology encouraged architecture that was incompatible with the traditional scale, massing and materials seen on South Temple. Probably the most discouraging episode in the street's history occurred during the 1960s and 1970s; so much so that the erosion of South Temple's historic appearance played a very large role in spurring the preservation movement in Utah. Since its adoption as a local district in 1976, efforts have focused on preserving historic buildings and on maintaining historic street features, such as carriage steps and sandstone retaining walls, that also contribute to our understanding of the history of South Temple and the City.

Development Trends

Known for its ongoing preservation efforts, the South Temple District is experiencing continued investment in the area, including renovation, additions to existing structures and infill construction. A wide range of construction projects is therefore anticipated.

Characteristics of the South Temple Historic District

The following is a summary of key features of the district:

- Street features continue to reflect South Temple's historic grandeur. These features include sandstone curb and gutters, sandstone carriage steps and hitching posts.
- About 1890 the city erected metal lattice-work posts to accommodate the trolley lines. Later these were used for traffic signals. Historically roses were planted to climb them to prevent children from playing on them. The posts now show substantial deterioration, as the traffic signals were too heavy and they have not been maintained.
- South Temple has mature landscaping, and the large trees planted in a formal manner are an important characteristic of the street.
- While South Temple is known for its mansions, there are many other homes that are not as grand but still continue to contribute to the streetscape and knowledge of the city's history. Similarly, historically South Temple dwellings have not been only single-family, owner occupied, nor has it been only residential. Several apartment buildings and commercial structures are of the historic period.

Goals for the District

The design goal for the South Temple District is to preserve its unique character. Preservation of the character, style and details of the many high style buildings is a high priority, as is assuring that new building will be in scale and compatible in character with the historic context.



Due to the large size of many of the buildings in the district, roof materials are very important visual features.

Streetscape Features

Walkways

Many residences are sited on a system of "platforms," which were created to provide level building areas. As a result, most of the South Temple mansions sit above street level, often with a series of stairs that link the front entry with the public sidewalk. The system of terraced building sites also establishes a fairly consistent pattern of landscaping and retaining walls that visually connect the blocks. These characteristics should be maintained.

13.35 A walkway to the building entry from the public sidewalk should be provided.

- The walk should be distinct from a driveway.
- Concrete is the dominant material; however, other materials, including modular pavers, also are appropriate for new walkways.

Site Design Features

South Temple Street developed with a variation in block sizes between the north and south sides of the street. The north side was platted with smaller lots, while the south side is characterized by more spacious parcels. The district is unified, however, by its consistent streetscape design and traditional siting, and its concentration of larger houses. The guidelines that follow strive to reinforce these traditional patterns.

Front Setback of Primary Structure

Historically, the larger mansions on the street were sited farther from the sidewalk than the smaller residences. Although a variety of setbacks is seen throughout the district, within individual blocks, most buildings appear to align within a narrow range of dimensions. This generally uniform setback alignment of an individual block should be maintained.

13.36 The front setback of a new structure should be kept in line with the median setback of historic properties on the block.

- In general, larger, taller masses should be set back farther from the front than smaller structures.
- In some cases, therefore, a setback that is greater than the median setbacks may be appropriate.



Porches and other detailing also are a part of the architectural detail that add interest to the street and help establish a human scale to building in the district.



The use of ornamentation on buildings is an established tradition in the district, and its continued use is encouraged. On new buildings, contemporary interpretations of building ornament and detail are especially appropriate.

South Temple Historic District

Side Yard Setback of Primary Structure

Many of the larger houses on the street have large side yard setbacks, which reinforce their stately appearance. Smaller residences are typically sited with their narrow side to the street. Both situations suggest that, traditionally, the side yard width was in proportion to the width of the lot. This characteristic should be maintained.

13.37 Side yard setbacks of a new structure, or an addition, should appear similar to those seen traditionally in the block.

- The traditional building pattern should be followed in order to continue the historic character of the street.
- The visual impact of both new construction and additions on neighboring side yards should be considered.

Curb Cuts

13.38 The visual impacts of curb cuts should be minimized.

- When planning a driveway, consider the impact of curb cuts on historic curbing material, such as granite and sandstone. Consider their retention and reuse.

The design guidelines apply in addition to those in relevant preceding chapters, which may include Rehabilitation Guidelines, Guidelines for New Construction and General Design Guidelines.

Service Areas

13.39 The negative visual impacts of service areas should be minimized.

- Service areas include locations for trash and recycling containers, transformers and other mechanical and electrical equipment that may require exterior facility.
- In all cases, these features should remain visually unobtrusive.
- Locate dumpsters and other service equipment to the rear of the lot, when physical conditions permit.
- Service areas should be screened from public view with fences, walls, planting, or a combination of these elements.

Siting of Additions

Buildings located along South Temple are generally large two and three story structures that can accommodate larger additions than houses in other districts. Although there should be a degree of flexibility in the size of additions in the South Temple district, these additions still should be designed to be compatible with the original structure.



Provide a walkway to the building entry from the public sidewalk.

Architectural Features

Porches

Porches were important design feature themselves and were also embellished with details that enlivened the character of the street. Porches also add interest to the street and help establish a human scale in the district.

13.40 When constructing a new building, the primary entrance to the house should be clearly defined.

- Use a porch, stoop, portico or similar one-story feature to indicate the entry.
- Orienting the entry to the street is preferred.
- Establishing a “progression” of entry elements, including walkway, landscape elements and porch also is encouraged.

13.41 When converting a building to another use, the historic location and character of the porch and primary entrance should be preserved.

13.42 A new building should be designed to be similar in scale to those seen traditionally on the block.

- Historically, most of the larger houses on South Temple appeared to have a height of two to three stories, while the smaller ones generally had heights of two stories.
- A front facade should appear similar in height to those seen historically on the block.
- A taller portion should be set back further on the lot.
- Story heights should appear similar to those seen historically.

- Use architectural details to give a sense of the traditional scale of the block.
- In the case of new apartment buildings, they should appear to be similar in mass and scale to historic apartment structures in the district.

Ornamentation

Most of the buildings in the South Temple district represent high-style forms of architecture, and in many cases, have been designed with elaborate architectural detailing, including intricate features and finishes. Ornamentation typically embellishes doors and windows, eaves, porches, and gable ends, while major wall surfaces are relatively simple.

The use of ornamentation on buildings is an established tradition in the district, and its continued use is encouraged. On new buildings, contemporary interpretations of building ornament and detail are especially appropriate.

13.43 The use of ornament and detail is encouraged.

- Such details should have a substantial “depth,” and be constructed of durable materials.
- While a range of materials is appropriate, details should have finishes that appear similar to those used traditionally.
- The details should appear integral to the overall design.

Building and Roof Materials

Due to the large size of many of the buildings in the district, roof materials are very important visual features. Slate, asphalt, wood, and tile shingles are all materials found on historic buildings. These materials and textures contribute to the character of the district. When roofing must be replaced, using a material similar to the original is preferred. On a new building, using a material similar in color and texture to those seen historically in the block also is appropriate.

13.44 Building materials that are similar to those used historically should be used.

- Appropriate building materials include brick, wood horizontal clapboard and shingles, stucco, smooth-faced stone and river rock.

13.45 Roofing materials that are similar in appearance to those seen historically should be used.

- Asphalt and wood shingles are appropriate to many styles seen historically.
- Clay tile is appropriate to Spanish, Mission and Colonial styles only. Concrete tiles may be appropriate because they often convey a scale and texture similar to materials employed historically.
- Large panelized products, such as standing seam metal, should be avoided.
- Colors should be muted; the overall texture of a roof should be uniform and consistent throughout the building.

Appropriateness of Use

13.46 When adapting a residence to another use, the original design character of the building should be preserved.

- When converted to a new use, a house should retain its residential image.

13.47 If the change from residential to another use requires more parking space, the parking should be located to the rear of the property and provide landscaping as a buffer.

- Landscape design for rear parking areas should help to integrate this use with its context.

Additional Information

Moss, Roger W. and Gail Caskey Winkler. *Victorian Exterior Decoration, How to Paint Your Nineteenth-Century American House Historically*. New York: Henry Holt and Co., 1987.

Schwinn III, Lawrence. *Old House Colors-An Expert's Guide to Painting Your Old (Or Not So Old) House*. New York: Sterling Publishing Co., Inc., 1990.

Alderson, Caroline. "Re-creating A 19th Century Paint Palette", *APT*, Vol. XVI No. 1, pgs. 47-56. 1984.

Bock, Gordon. "Colorful Issues in Choosing Exterior Paint", *Old-House Journal*, pgs. 50-55. July/August 1996.

Design Guidelines for the University Historic District



University Historic District

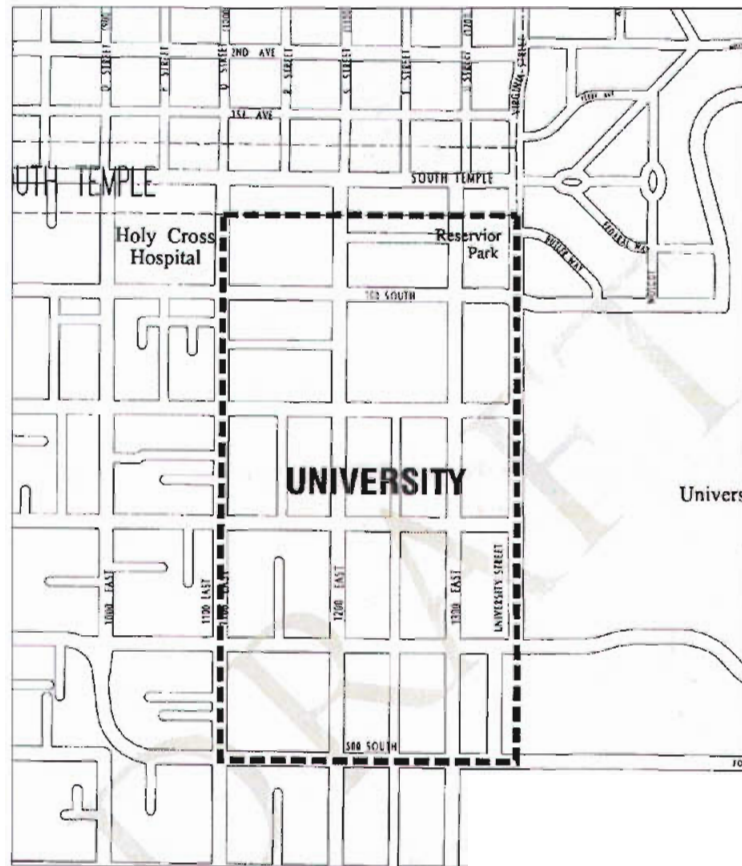

The University Historic District

Scale: 1"=100'

Cover page image: Despite modern intrusions and the mix of single-family dwellings and apartment buildings, the University Historic District exhibits the most homogenous blend of architecture and consistent streetscape of all the local districts. A progression of entry features seen here includes a walkway with steps leading to a broad front porch.

Historic Architectural Character

Despite modern intrusions and the mix of single-family dwellings and apartment buildings, the University Historic District exhibits the most homogenous blend of architecture and consistent streetscape of all the local districts. Although several homes remain that were built as early as 1885, for the most part its development coincided with the first two decades of the 20th century – a period marked by prosperity and growth. Municipal improvements, such as the installation of utilities and the extension of electric streetcar lines throughout the city created new opportunities for suburban expansion, especially on the east bench. The establishment of the University of Utah at its current location in 1901 ensured the viability of this neighborhood and influenced its development. Since that time the area has been home to many university faculty and staff members, although the area was not popular for student residency until after World War II. Many professional people not affiliated with the University have also resided in the neighborhood.

The affluence of its residents, its comparatively orderly development, and the influence of the Progressive era, are all reflected in the district's architecture and streetscapes. Four-square architecture, also known as the "box," was another popular choice during this time and is well represented in the University District. Some have Colonial Revival details, such as Doric porch columns, but examples in this neighborhood are generally Prairie School in style. Many are scattered throughout the district, but several of the most appealing are clustered along 100 South between 1200 East and Douglas Street.

HISTORIC ARCHITECTURAL CHARACTER	U:3
DEVELOPMENT TRENDS	U:5
CHARACTERISTICS OF UNIVERSITY	U:5
GOALS FOR THE DISTRICT	U:6
STREETSCAPE FEATURES	U:6
STREET PATTERN	U:6
ALLEYS	U:6
ARCHITECTURAL FEATURES	U:7
BUILDING FORM, MASS, SCALE	U:7
PORCHES	U:8
BUILDING AND ROOF MATERIALS	U:8

University Historic District



During the beginning of the twentieth century, the bungalow proved to be a very popular building form in the University district.

At least two of these were designed by the local firm of Ware and Treganza and represent the firm's earliest work in the Prairie style. While not as elaborate as the mansions along South Temple that were built for similarly wealthy and prominent citizens, many of the homes in the University district were beautifully fitted and very comfortable.

The majority of the existing construction occurred after 1900, but this district contains many structures built before this time that exhibit the asymmetrical, vertical and multi-textured surface treatment associated with Victorian-era styles. Shingle style houses and Victorian Eclectic examples exist throughout the district. The Hudson Smith house at 221 South 1200 East, built in 1896, was apparently an ornate Victorian with plenty of surface decoration. However, when subsequent owners, Seibert and Emily Mote purchased it in 1930, they undertook an extensive remodeling to make the house look "old." Their attempts reflect the popular revival of federal and Georgian styles in the 1920s and 1930s and resulted in a unique blend of the Federal and Shingle styles.

The few pre-1900 structures are most prevalent near the western and northern boundaries of the neighborhood. Not everyone who resided in the neighborhood was affluent, professional or associated with the University of Utah. A look at city directories indicates that government clerks, railroad workers and tradesmen lived on Bueno Avenue, a street lined with similar frame and brick cottages that were constructed about 1905. Speculative development undertaken by real estate companies, similar to that erected by the Anderson Real Estate firm in Central City, also occurred near the University.

The University district also has a small but lively commercial area on the six blocks between 200 and 400 South and University and 1300 East streets. No business building is higher than two stories and few are from the historic period. Exceptions include several four-square residences that now house small businesses and the old Crystal Palace Market, built in 1930. Fire station number eight was converted into a restaurant, but has maintained much of its original character. It was designed by the City Engineer's office in the Period Revival style: a conscious attempt by Salt Lake City Corporation to ensure that this institutional structure was compatible with its residential surroundings.

As in all of the historic districts, more recent, incompatible architecture has detracted from the visual unity of the streetscape. Because of their low massing and because of zoning restrictions commercial structures are not the problem; instead multifamily structures represent the most disruptive intrusions. The 1960s era apartment buildings, known as “box-cars” because of their long narrow shape with an orientation away from the street, are scattered in the neighborhood and a condominium project, University Gardens, towers over its surroundings on 1300 East. It should be pointed out, however, that several earlier apartment buildings contribute architecturally to the district, such as the Commander Apartments across the street that were built in 1928.

Within the last decade more interest has been shown in maintaining the historic streetscape and integrity of the University neighborhood. These efforts resulted in a successful request to the City to create a local historic district requiring design review, and in the rewriting of the zoning ordinance in 1994 that reduced permitted densities in the neighborhood.

Development Trends

Known for its ongoing preservation efforts, the University District is experiencing continued investment in the area, including renovation, additions to existing buildings and infill construction. A wide range of construction projects is therefore anticipated, including renovation and new buildings.

Characteristics of the University Historic District

The following is a summary of key features of the district that should be respected.

- Setbacks are uniform.
- Garages are set back on the lot and are detached from the house. They are almost all accessed by single-car driveways from the streets; however, north/south alleys bisect the street grid.
- There is a substantial variation in topography. Rather than address this through the architecture, it historically was addressed through site features such as retaining walls. The materials of the walls vary and include cobblestone, sandstone, and concrete. Yards often have steep slopes.
- The street pattern is one of a grid. Lot size is uniform, although Bueno, Alameda and some blocks of Elizabeth Street have smaller lots, increasing the density.
- The small stores, restaurants and businesses along 1300 East and University streets provide a neighborhood commercial center unusual in Salt Lake because of their pedestrian orientation. Parking is generally only available on the street. Many of the businesses are located in former homes, and thus are of a scale compatible to the district’s residential character.
- The large retaining wall and corresponding street pattern on 200 South and 1200 East is a unique feature to the neighborhood. Nearby stairs provide pedestrian access between these two streets.

Goals for the District

The design goal for the University District is to preserve the character of its streetscapes and the integrity of its individual historic structures. In particular, preservation of the streetscape, including parkways, park strips, front yards and walkways is a high priority.



"Victorian Eclectic", a loose but apt description, was the most popular of styles used in the first wave of building after about 1885.

Streetscape Features

Street Pattern

The University district developed according to a grid system, which is characterized by wide streets and large blocks. Sidewalks are detached with a planting strip between the sidewalk and the curb. Narrow lanes with small cottages sometimes occur, contrasting with the broader streets. This traditional rectilinear pattern, along with a uniformity of siting and somewhat homogeneous housing stock, created the district's distinct continuity of the streetscape. Preservation of this street pattern is a high priority.

Alleys

A system of alleys provides a contrast to the wide, formal streets and large blocks on the University district. Aside from creating visual diversity in the neighborhood, alleys are functional spaces that relieve traffic on larger streets and provide access to parking and service areas. The historic character of alleys should be maintained.

13.48 Alleys where they exist should be maintained, preserving their simple character.

13.49 The established pattern of on-street parking should be maintained.

Architectural Features

Building Form, Mass and Scale

The University district consists primarily of turn of the century residential structures, which are generally similar in mass and scale. However, a commercial area along 1300 East and University Street and various apartment buildings exhibit slightly larger building massing. Nonetheless, these structures generally conform to a consistent, relatively low neighborhood scale. This character of the district provides a context with which to relate new infill.

13.50 A new building should be designed to be similar in mass to those that were typical historically in the district.

- Subdivide a larger mass into smaller “modules” that are similar in size to buildings seen traditionally, wherever feasible.
- Where a new commercial structure is to be constructed adjacent to a residential area, the building should be stepped down in height to minimize impact on the residences.

The design guidelines apply in addition to those in relevant preceding chapters, which may include Rehabilitation Guidelines, Guidelines for New Construction and General Design Guidelines.

13.51 A new building should be designed to be similar in scale to those seen traditionally on the block.

- Historically, most houses appeared to have a height of one, one-and-one half or two stories.
- A new front facades should appear similar in height to those seen historically in the block.
- Taller portions should be set back farther on the lot.
- Story heights should appear similar to those seen historically.
- Use architectural details similar in size and proportion to those seen traditionally to give a sense of scale, wherever feasible.

13.52 A new building should be designed to have a primary form similar to those seen historically.

- Since there is such a high concentration of bungalows in the University district, the primary form of the house was a single rectangular volume.
- In some styles, smaller, subordinate masses were then attached to this primary form.
- New buildings should continue this tradition.

13.53 A new roof should appear similar in form and scale to those of typical houses seen historically in the block.

- Pitched roofs, either hip or gable, are preferred.
- Slopes should be within the range of those seen historically in the block.
- The depth of the overhang of the eaves should also follow historic precedent. This is especially important on bungalows, where the overhang is fairly deep.

Porches

Because of the number of early twentieth century residences, including period revival houses and craftsman bungalows, the streetscape is unified by the strong presence of porches. In fact, the bungalow was customarily designed with a spacious front porch, usually accented by features such as wide, stone piers and brackets. Where historic porches exist, they should be preserved. They also are strongly encouraged in new construction.

13.54 The primary entrance to the house should be clearly defined.

- A porch, stoop, portico or similar one-story feature should be used to indicate the entry.
- Orienting the entry to the street is preferred.
- Establishing a “progression” of entry elements, including walkway, landscape elements and porch also is encouraged.



Roof pitches may vary from block to block. The roof on this Tudor Revival house is very steep.

Building and Roof Materials

Due to the relative architectural homogeneity of the district, the range of historic roof materials is narrow. This similarity of materials should be maintained.

13.55 Building materials should appear similar to those seen historically.

- Brick, stucco, and wood are all appropriate building materials.
- Because of the large number of bungalows in the district, many foundations and posts are constructed of stone.
- Using stone, similar to that employed historically, is preferred.
- Using field stone, veneers applied with the bedding plane in a vertical position, or aluminum or vinyl siding are inappropriate.

3.56 Roofing materials should be similar in appearance to those seen historically.

- Asphalt and wood shingles are appropriate.
- Concrete tiles may also be appropriate where they convey a scale and texture similar to materials employed historically for that style.
- Large panelized products, such as standing seam metal, should be avoided.
- Colors should be muted; the overall texture of a roof should be consistent throughout the building.

Design Guidelines for the Westmoreland Place Historic District



To be Completed - 2012

Design Guidelines for Cultural Resources in Salt Lake City

Glossary

A. Procedural Definitions

Certificate of Appropriateness A document issued by the Historic Landmark Commission (HLC) allowing an applicant to proceed with a proposed alteration, demolition, or new construction in locally-designated historic districts or properties listed in the Salt Lake City Register of Cultural Resources, following a determination of the proposal's suitability according to applicable criteria.

Process The established procedures by which the various actions that may be taken by the Historic Landmark Commission are carried out.

Public notice Notice provided to interested parties before a commission takes action.

B. Technical Definitions

Adaptive Use Original use such as a residence converted into offices. The reuse of a building or structure, usually for purposes different from the original use such as residence converted into offices.

Addition New construction added to an existing building or structure.

Alteration Work that affects the exterior appearance of a property.

Building A structure with a roof, intended for shelter or enclosure such as a dwelling or garage.

Character The qualities and attributes of a building, structure, site, street or district.

Configuration The arrangement of elements and details on a building, structure or site which help to define its character.

Compatible In harmony with surroundings.

Context The setting in which a historic element, site, building, structure, street, or district exists.

Demolition Any act which destroys in whole or in part a building or structure.

Demolition by Neglect The destruction of a building or structure through abandonment or lack of maintenance.

Design Guidelines Criteria developed to provide direction to projects conducted within the context of an area regarding design concerns and to help ensure that rehabilitation projects and new construction respect the character of designated buildings and districts.

Element A material part or detail of a site, building, structure, street, or district.

Elevation Any one of the external vertical planes of a building. (or) An external vertical plane of a structure.

Fabric The physical material of a building, structure, site, or community conveying an interweaving of component parts.

Floor Area Ratio The relationship of the total floor area of a building to the land area of its site, as defined in a ratio in which the numerator is the floor area, and the denominator is the site area.

Historic District A geographically definable area with a significant concentration of buildings, structures, sites, spaces, or objects unified by past events, physical development, design, setting, materials, workmanship, sense of cohesiveness or related historical and aesthetic associations. The significance of a district may be recognized through listing in a local, state, or national landmarks register and may be protected legally through enactment of a local historic district ordinance administered by a historic district board or commission.

Glossary

Historic Imitation New construction or rehabilitation where elements or components mimic an architectural style but are not of the same historic period as the existing buildings (historic replica).

Historic Landmark Commission The City's governmental entity responsible for administering the criteria set forth in this document and in the Salt Lake City Zoning Ordinance (Section 21A.34.020) as applies to locally-designated landmark sites and historic districts.

Infill New construction in historic districts on vacant lots or to replace existing buildings.

Landmark Site Any site included on the Salt Lake City Register of Cultural Resources. Such sites are of exceptional importance to the City, State, region or nation and impart high artistic, historic and/or cultural values.

Landscape The totality of the built or human-influenced habitat experienced at any place. Dominant features are topography, plant cover, buildings, or other structures and their patterns.

Maintain To keep in an existing state of preservation or repair.

Mothballing Implementing temporary measures to stabilize and protect a building from deterioration and vandalism.

New construction Construction which is characterized by the introduction of new elements, sites, buildings, or structures or additions to existing buildings and structures in historic areas and districts.

Preservation Generally, saving from destruction or deterioration old and historic buildings, sites, structures, and objects and providing for their continued use by means of restoration, rehabilitation, or adaptive use.

Proportion Harmonious relation of parts to one another or to the whole.

Protection The act or process of applying measures designed to affect the physical condition of a property by defending or guarding it from deterioration, loss or attack, or to cover or shield the property from danger of injury. In the case of buildings and structures, such treatment is generally of a temporary nature and anticipates future historic preservation treatment; in the case of archaeological sites, the protective measure may be temporary or permanent.

Reconstruction The act or process of reproducing by new construction the exact form and detail of a vanished building, structure, or object, or a part thereof, as it appeared at a specific period of time.

Rehabilitation The act or process of returning a property or building to usable condition through repair, alteration, and/or preservation of its features which are significant to its historical, architectural, and cultural values.

Renovation The act or process of returning a property to a state of utility through repair or alteration which makes possible a contemporary use.

Restoration The act or process of accurately taking a building's appearance back to a specific period of time by removing later work and by replacing missing earlier features to match the original.

Retain To keep secure and intact. In the guidelines, "retain" and "maintain" describe the act of keeping an element, detail, or structure and continuing the same level of repair to aid in the preservation of elements, sites and structures.

Re-use To use again. An element, detail, or structure might be reused in historic districts.

Rhythm Movement or fluctuation marked by the regular occurrence or natural flow of related elements.

Scale Proportional elements that demonstrate the size, materials, and style of buildings.

Setting The sum of attributes of a locality, neighborhood, or property that defines its character.

Significant Having particularly important associations within the contexts of architecture, history, and culture.

Stabilization The act or process of applying measures to reestablish a weather resistant enclosure and the structural stability of a deteriorated property while maintaining its present form.

Streetscape The distinguishing character of a particular street as created by its width, degree of curvature, paving materials, design of the street furniture, and forms of surrounding buildings.

Style A type of architecture distinguished by special characteristics of structure and ornament and often related in time; also a general quality of a distinctive character.

Visual Continuity A sense of unity or belonging together that elements of the built environment exhibit because of similarities among them.

Glossary of Terms

Alignment The arrangement of objects along a straight line.

Apron A decorative, horizontal trim piece on the lower portion of an architectural element.

Arch A construction which spans an opening and supports the weight above it. (see flat arch, jack arch, segmental arch and semi-circular arch).

Ashlar A square, hewn stone used in building. It also refers to a thick dressed, square stone used for facing brick walls, etc.

Attic The upper level of a building, not of full ceiling height, directly beneath the roof.

Balcony A platform projecting from the wall of an upper story, enclosed by a railing or balustrade, with an entrance from the building and supported by brackets, columns, or cantilevered out.

Baluster One of a series of Short, vertical, often vase-shaped members used to support a stair or porch handrail, forming a balustrade.

Balustrade An entire rail system with top rail and balusters.

Bargeboard A board which hangs from the projecting end of a gable roof, covering the end rafters, and often sawn into a decorative pattern.

Bay The portion of a facade between columns or piers providing regular divisions and usually marked by windows.

Bay window A projecting window that forms an extension to the floor space of the internal rooms; usually extends to the ground level.

Belt course A horizontal band usually marking the floor levels on the exterior facade of a building.

Board and batten Siding fashioned of boards set vertically and covered where their edges join by narrow strips called battens.

Bond A term used to describe the various patterns in which brick (or stone) is laid, such as "common bond" or "Flemish bond."

Bracket A projecting element of wood, stone or metal which spans between horizontal and vertical surfaces (eaves, shelves, overhangs) as decorative support.

Bulkhead The structural panels just below display windows on storefronts. Bulkheads can be both supportive and decorative in design. 19th century bulkheads are often of wood construction with rectangular raised panels. 20th century bulkheads may be of wood, brick, tile, or marble construction. Bulkheads are also referred to as kickplates.

Came Metal struts supporting leaded glass.

Glossary

Canopy A roofed structure constructed of fabric or other material placed so as to extend outward from a building providing a protective shield for doors, windows and other openings, supported by the building and supports extended to the ground directly under the canopy or cantilevered from the building.

Capital The head of a column or pilaster.

Carrara Glass Tinted glass widely used for storefront remodeling during the 1930s and 1940s. Carrara glass usually came in black, tan, or dark red colors.

Casement window A window with one or two sashes which are hinged at the sides and usually open outward.

Clapboards Horizontal wooden boards, thinner at the top edge, which are overlapped to provide a weather-proof exterior wall surface.

Classical order Derived from Greek and Roman architecture, a column with its base, shaft, capital and entablature having standardized details and proportions, according to one of the five canonized modes Doric, Tuscan, Ionic, Corinthian, or Composite.

Clipped gable A gable roof where the ends of the ridge are terminated in a small, diagonal roof surface.

Column A cylindrical or square vertical structural or ornamental member.

Common bond A brickwork pattern where most courses are laid flat, with the long "stretcher" edge exposed, but every fifth to eighth course is laid perpendicularly with the small "header" end exposes, to structurally tie the wall together.

Corbel In masonry, a projection, or one of a series of projections, each stepped progressively further forward with height and articulating a cornice or supporting an overhanging member.

Corinthian order Most ornate classical order characterized by a capital with ornamental acanthus leaves and curled fern shoots.

Cornice The uppermost, projecting part of an entablature, or feature resembling it. Any projecting ornamental molding along the top of a wall, building, etc.

Cresting A decorated ornamental finish along the top of a wall or roof, often made of ornamental metal.

Cross-gable A secondary gable roof which meets the primary roof at right angles.

Dentils A row of small tooth-like blocks in a classical cornice.

Doric order A classical order with simple, unadorned capitals, and with no base.

Dormer window A window that projects from a roof.

Double-hung window A window with two sashes, one sliding vertically over the other.

Eave The edge of a roof that projects beyond the face of a wall.

E.I.F.S. Stands for "Exterior Insulating and Finish System." This is a process by which a styrene board is adhered to wall sheathing and an elastomeric, synthetic stucco is applied. At this writing E.I.F.S. is generally referred to as "dryvit," but this is a brand name.

Ell The rear wing of a house, generally one room wide and running perpendicular to the principal building.

Engaged column A column that is in direct contact with a wall; at least half of the column extends beyond the plane of the wall to which it is attached.

Entablature A part of a building of classical order resting on the column capital; consists of an architrave, frieze, and cornice.

Facade Any of the exterior faces of a building.

False Front A front wall which extends beyond the sidewalls of a building to create a more imposing facade.

Fanlight A semi-circular window usually over a door with radiating muntins suggesting a fan.

Fascia A projecting flat horizontal member or molding; forms the trim of a flat roof or a pitched roof; also a part of a classical entablature.

Fenestration The arrangement of windows and other exterior openings on a building.

Finial A projecting decorative element at the top of a roof turret or gable.

Fishscale shingles A decorative pattern of wall shingles composed of staggered horizontal rows of wooden shingles with half-round ends.

Flashing Thin metal sheets used to prevent moisture infiltration at joints of roof planes and between the roof and vertical surfaces.

Flat arch An arch whose wedge-shaped stones or bricks are set in a straight line; also called a jack arch.

Flemish bond A brick-work pattern where the long "stretcher" edge of the brick is alternated with the small "header" end for decorative as well as structural effectiveness.

Fluting Shallow, concave grooves running vertically on the shaft of a column, pilaster, or other surface.

Foundation The lowest exposed portion of the building wall, which supports the structure above.

Frieze The middle portion of a classical cornice; also applied decorative elements on an entablature or parapet wall.

Gable The triangular section of a wall to cany a pitched roof.

Gable roof A pitched roof with one downward slope on either side of a central, horizontal ridge.

Gambrel roof A ridged roof with two slopes on either side.

Ghosts Outlines or profiles of missing buildings or building details. These outlines may be visible through stains, paint, weathering, or other residue on a building's facade or side elevation.

Guardrail A building component or a system of building components located at or near the open sides of elevated walking surfaces that minimizes the possibilities of a fall fi'om the walking surface to a lower level.

Handrail A horizontal or sloping rail intended for grasping by the hand for guidance or support.

Hipped roof A roof with uniform slopes on all sides.

Hood molding A projecting molding above an arch, doorway, or window, originally designed to direct water away fi'om the opening; also called a drip mold.

Ionic order One of the five classical orders used to describe decorative scroll capitals.

Jack arch (see Flat arch)

Joist One of the horizontal wood beams that support the floors or ceilings of a house. They are set parallel to one another—usually from 1'0" to 2'0" apart—and span between supporting walls or larger wood beams.

Keystone The wedge-shaped top or center member of an arch.

Knee brace An oversize bracket supporting a cantilevered or projecting element.

Lancet Window A narrow, vertical window that ends in a point.

Lap Siding See clapboards.

Glossary

Lintel The horizontal top member of a window, door, or other opening.

Luxfer glass A glass panel made up of small leaded glass lights either clear or tinted purple. These panels were widely used for storefront transoms during the early 20th century.

Mansard roof A roof with a double slope on all sides, with the lower slope being almost vertical and the upper almost horizontal.

Masonry Work using brick, stone, concrete block, tile, adobe or similar materials.

Massing The three-dimensional form of a building.

Metal standing seam roof A roof composed of overlapping sections of metal such as copper-bearing steel or iron coated with a terne alloy of lead and tin. These roofs were attached or crimped together in various raised seams for which the roof are named.

Modillion A horizontal bracket, often in the form of a plain block, ornamenting, or sometimes supporting, the underside of a cornice.

Mortar A mixture of sand, lime, (and in more modern structures, cement), and water used as a binding agent in masonry construction.

Molding A decorative band or strip of material with a constant profile or section designed to cast interesting shadows. It is generally used in cornices and as trim around window and door openings.

Mullion A heavy vertical divider between windows or doors.

Multi-light window A window sash composed of more than one pane of glass.

Muntin A secondary framing member to divide and hold the panes of glass in multi-light window or glazed door.

Oriel window A bay window which emerges above the ground floor level.

Paired columns Two columns supported by one pier, as on a porch.

Palladian window A window with three openings, the central one arched and wider than the flanking ones.

Paneled door A door composed of solid panels (either raised or recessed) held within a framework of rails and stiles.

Parapet A low horizontal wall at the edge of a roof.

Pediment A triangular crowning element forming the gable of a roof; any similar triangular element used over windows, doors, etc.

Pier A vertical structural element, square or rectangular in cross-section.

Pilaster A rectangular pillar attached, but projecting from a wall, resembling a classical column.

Pitch The degree of the slope of a roof.

Pony wall Low wall, between 24" to 36" high, that are used to enclose porches or balconies. Also known as "wing" walls.

Portico A roofed space, open or partly enclosed, forming the entrance and centerpiece of the facade of a building, often with columns and a pediment.

Portland cement A strong, inflexible hydraulic cement used to bind mortar.

Post A piece of wood, metal, etc., usually long and square or cylindrical, set upright to support a building, sign, gate, etc.; pillar; pole.

Pressed tin Decorative and functional metalwork made of molded tin used to sheath roofs, bays, and cornices.

Pyramidal roof A roof with four identical sides rising to a central peak.

Quoins A series of stone, bricks, or wood panels ornamenting the outside of a wall.

Rafter Any of the beams that slope from the ridge of a roof to the eaves and serve to support the roof.

Ridge The top horizontal member of a roof where the sloping surfaces meet.

Roof The top covering of a building. Following are some types:

- **Gable** roof has a pitched roof with ridge and vertical ends.
- **Hip** roof has sloped ends instead of vertical ends.
- **Shed** roof (lean-to) has one slope only and is built against a higher wall.
- **Clipped gable or hipped gable** is similar to gable but with the end clipped back.
- **Gambrel** roof is a variation of a gable roof, each side of which has a shallower slope above a steeper one.
- **Mansard** roof is a roof with a double slope; the lower slope is steeper than the upper.

Rusticated Roughening of stonework or concrete blocks to give greater articulation to each block.

Sash The moveable framework containing the glass in a window.

Segmental arch An arch whose profile or radius is less than a semicircle.

Semi-circular arch An arch whose profile or radius is a half-circle the diameter of which equals the opening width.

Shape The general outline of a building or its facade.

Sheathing An exterior covering of boards or other surface applied to the frame of the structure. (see Siding)

Shed roof A gently-pitched, almost flat roof with only one slope.

Sidelight A vertical area of fixed glass on either side of a door or window.

Siding The exterior wall covering or sheathing of a structure.

Sill The bottom crosspiece of a window frame.

Soffit The underside of a structural part, as of a beam, arch, etc.

Spindles Slender, elaborately turned wood dowels or rods often used in screens and porch trim.

Stile A vertical piece in a panel or frame, as of a door or window.

Stretcher bond A brickwork pattern where courses are laid flat with the long "stretcher" edge exposed.

Stucco An exterior wall covering that consists of lime, cement and sand, applied directly or over a wood or metal lath. It is usually applied in three coats.

Surround An encircling border or decorative frame, usually at windows or doors.

Swag Carved ornament on the form of a cloth draped over supports, or in the form of a garland of fruits and flowers,

Terra-cotta Decorative building material of baked clay. Terra cotta was often glazed in various colors and textures. Terra cotta was widely used for cornices, inset panels, and other decorative facade elements from ca. 1880 to 1930.

Transom A horizontal opening (or bar) over a door or window.

Trim The decorative framing of openings and other features on a facade.

Turret A small slender tower.

Veranda A covered porch or balcony on a building's exterior.

Glossary

Vergeboard The vertical face board following and set under the roof edge of a gable, sometimes decorated by carving.

Vernacular A regional form or adaptation of an architectural style.

Wall dormer Dormer created by the upward extension of a wall and a breaking of the roofline.

Water table A projecting horizontal ledge, intended to prevent water from running down the face of a wall's lower section.

Weatherboard Wood siding consisting of overlapping boards usually thicker at one edge than the other.

Window Parts The moving units of a window are known as sashes and move within the fixed frame. The sash may consist of one large pane of glass or may be subdivided into smaller panes by thin members called muntins or glazing bars. Sometimes in nineteenth-century houses windows are arranged side by side and divided by heavy vertical wood members called mullions. For a diagram of window parts, see pages 72 and 73.

Historic Preservation Resources - Web Sites

Salt Lake City Corporation – Planning & Historic Preservation

<http://www.slcclassic.com/ced/planning/>

<http://www.slcclassic.com/ced/hlc/default.asp>

National Park Service – Technical Preservation Services

<http://www.nps.gov/tps/>

S of I Standards

<http://www.nps.gov/tps/standards/four-treatments.htm>

<http://www.nps.gov/tps/standards/rehabilitation.htm>

<http://www.nps.gov/tps/standards/applying-rehabilitation.htm>

S of I Guidelines

<http://www.nps.gov/tps/standards/rehabilitation/rehab/stand.htm>

<http://www.nps.gov/tps/standards/rehabilitation/sustainability-guidelines.pdf>

Preservation Briefs

<http://www.nps.gov/tps/how-to-preserve/briefs.htm>

Preservation Technical Notes

<http://www.nps.gov/tps/how-to-preserve/tech-notes.htm>

Cultural Landscapes

<http://www.nps.gov/tps/how-to-preserve/cultural-landscapes.htm>

Incentives

<http://www.nps.gov/history/hps/tps/tax/incentives/index.htm>

State Historic Preservation Office, Utah

http://history.utah.gov/state_historic_preservation_office/index.html

National Register of Historic Places

http://history.utah.gov/historic_buildings/national_register/index.html

Research

http://history.utah.gov/historic_buildings/information_and_research/index.html

Certified Local Government

http://history.utah.gov/historic_buildings/certified_local_government/index.html

Financial Assistance

http://history.utah.gov/historic_buildings/financial_assistance/index.html

Historic Preservation Contractor Directory

<http://history.utah.gov/apps/contractors.html>

Utah's Historic Architecture Guide

<http://history.utah.gov/architecture/index.html>

Preservation Organizations

http://history.utah.gov/historic_buildings/preservation_organizations/index.html

Publications

http://history.utah.gov/historic_buildings/publications/preservation_publications.html#pubs

Utah Heritage Foundation

<http://www.utahheritagefoundation.com/>

Financial Assistance

<http://www.utahheritagefoundation.com/preservation-resources/financial-resources>

Resources

<http://utahheritagefoundation.com/preservation-resources>

Tours and Events

<http://www.utahheritagefoundation.com/tours-and-events>

Awards

<http://utahheritagefoundation.com/saving-places/heritage-awards>

National Trust for Historic Preservation

<http://www.preservationnation.org/>

Resources for Homeowners

<http://www.preservationnation.org/resources/homeowners/>

Sustainability

<http://www.preservationnation.org/issues/sustainability/>

Community Revitalization

<http://www.preservationnation.org/issues/community-revitalization/>

Advisory Council on Historic Preservation

<http://www.achp.gov/>

Economic Impact of Historic Preservation

<http://www.achp.gov/economicstudies.html>

National Alliance of Preservation Commissions

<http://napc.uga.edu/>

Publications

<http://napc.uga.edu/programs/napc/publications.htm>

Preservation Links

<http://napc.uga.edu/programs/napc/links.htm>

The Association for Preservation Technology International

<http://www.apti.org/>

Publications

<http://www.apti.org/publications/index.cfm>

Resources

<http://www.apti.org/publications/tech-publications.cfm>

Preservation Trades Network

<http://www.iptw.org/>

Window Preservation Standards Collaborative

<http://ptnresource.org/WPSC/about/>

National Preservation Institute

<http://www.npi.org/>

DRAFT

MINUTES – HISTORIC LANDMARK COMMISSION PUBLIC HEARING DECEMBER 1, 2011

PLNPCM2011-00471 Revisions to the Residential Design Guidelines for Historic Districts and Landmark Sites - A petition initiated by Mayor Ralph Becker to revise the Design Guidelines for Residential Historic Districts in Salt Lake City regulated by the H Historic Overlay Zone. The design guidelines have been used since 1999 providing advice to owners and applicants, and serving as review and decision-making criteria for the public, the Commission and Staff. They will be revised to reflect historic preservation design guidelines best practice in organization, clarity, and current issues.

Mr. Carl Leith, Senior Planner reviewed the changes to the document as outlined in the Staff Report.

- Revisions have been made to the organization and refinement of the Preservation in Salt Lake City introductory chapter, including the format example diagrams in how to use the design guidelines. Additional material will be required to expand the introductory coverage to include Commercial and Signs.
- Some refinements and corrections have been made to the text throughout, with the completion of some notation for several diagrams and drawings.
- Revisions to the text include many but not all comments made at this point.
- A first draft of the Glossary is available with this draft. This will be further supplemented and revised to serve as a joint resource for the three sets of design guidelines.

Mr. Leith stated Staff recommended the Commission consider the second draft in detail, forward thoughts and comments to Staff to inform the further and final draft of the document and continue the Public Hearing and review to the meeting on December 15. He stated a Subcommittee meeting was scheduled for Monday, December 5, at 9:00 a.m. to review the document further. He thanked the Commission for their time and help with updating the document.

The Commissioners said they would give their changes and comments to Mr. Leith to review in time for the Monday meeting. They discussed the organization of the introduction section and moving the general information to the beginning of the document with the specific information following. They asked Mr. Leith to provide a summary of the major changes to the document for the next meeting.

Chairperson Oliver asked if more information was available to address multifamily housing.

Mr. Leith explained that information was taken out of the presented document and would be a separate document with its own design guidelines, as it was a key building type across the city.

PUBLIC HEARING 8:58:34 PM

Chairperson Oliver opened the Public Hearing. Seeing there was no one present to speak on the issue the Public Hearing was closed.

EXECUTIVE SESSION 8:58:40 PM

MOTION 8:58:43 PM

Commissioner Funk moved in the case of PLNPCM2011-00471 the Historic Landmark Commission continue the Public Hearing until December 15, 2011, with the revisions suggested to the Staff. Commissioner Hart seconded the motion. Commissioners Hart, Richards, Bevins, Funk, Harding, James and Davis voted *Aye*. The motion passed with a 7-0 vote, Chairperson Oliver did not vote.

Attachment C

REPORT – OPEN CITY HALL ONLINE FORUM – RESIDENTIAL DESIGN GUIDELINES

Revisions to the Residential Design Guidelines for Historic Districts and Landmark Sites

What are your opinions about the proposed guidelines?

Public comments as of December 7, 2011, 8:56 PM

All Participants around Salt Lake City

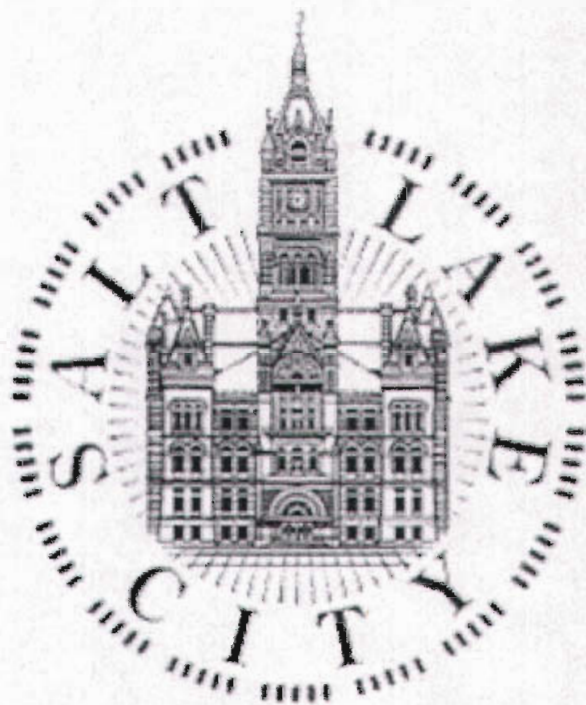

As with any public comment process, participation in Open City Hall is voluntary. The statements in this record are not necessarily representative of the whole population, nor do they reflect the opinions of any government agency or elected officials.

Revisions to the Residential Design Guidelines for Historic Districts and Landmark Sites

What are your opinions about the proposed guidelines?

Introduction

The City is making some revisions to the Design Guidelines for Historic Residential Properties in Salt Lake City. These design guidelines have provided support, information and guidance for owners, designers, contractors, City staff and the Historic Landmark Commission since their adoption in 1999.

Revisions to the Residential Design Guidelines for Historic Districts and Landmark Sites

What are your opinions about the proposed guidelines?

As of December 7, 2011, 8:56 PM, this forum had:

Attendees:	284
Participants around Salt Lake City:	12
Minutes of Public Comment:	36

Revisions to the Residential Design Guidelines for Historic Districts and Landmark Sites

All Participants around Salt Lake City

Richard Middleton in District 3

December 6, 2011, 12:36 PM

I am surprised how little comment this controversial topic has generated. My suspicion is that property owners do not wish to get involved, for fear of bringing the City inspectors around to check on what they are doing. When we moved here from the East coast, we were surprised about how everyone skirted around the topic of whether our house was historic or not; only later did we discover that no one wanted to deal with City Hall, and that historic status was more a liability than an asset. That is deplorable.

We found that we had to deal with requirements from the City that seemed almost designed to encourage owners to avoid getting permits: replacement windows had to be made by Pella, soffits had to be relined with beadboard (at that time not being milled anywhere locally), guttering and downspouts had to be steel, with the downspouts of an unusual (and unobtainable) cross-section, and so on. Luckily these authoritative pronouncements changed depending on who was available on any particular day, and so we were eventually able to restore our house without going bankrupt.

I am very much in favor of historic conservation, but I believe that the City needs to be flexible, using judgement and common sense to decide, in consultation with the homeowner, what is permitted and what is not in each particular case. Window choice provides a good example: Must one revert to the original arrangement of mullions and muntins, removing all picture windows (perhaps installed decades ago, once larger panes became available and affordable)? Is the additional cost of wooden windows rather than vinyl justified, even though wood in Utah's climate is a maintenance problem, and it is important not to discourage people from upgrading to energy-efficient installations? How does one reconcile requiring authentically historic wood windows with allowing a decidedly 21st-century solar array on the roof?

I believe that many older houses in the city are owned by people who do not have unlimited resources for remodeling, and many are rented out. Excessively rigid requirements are likely to lead either to deferred repairs and consequent deterioration, or to people continuing clandestine remodeling, probably with unfortunate results.

Name not shown in District 4

December 2, 2011, 1:23 PM

I would like to see provisions for removing old building that are abandoned or boarded (for more than a certain number of years). Old doesn't equal historic, so any guidelines that would help preserve charm and character in older homes and would provide "reasonable guidelines" for new construction in historic areas would be my opinion. Thank you.

Name not shown in District 6

December 2, 2011, 11:20 AM

This is simple, guys. There are only a few streets here in Yalecrest that truly want (and need) a preservation system in place. They want it, they have the bucks to continue making those streets shine, so let 'em have it. Why mess with everyone else? Simple solution: start with a max of a few streets (no more than 30-40 homes) and let it grow from there. We elected a new District 6 dude to resolve this, so let's resolve it. Your move.

Revisions to the Residential Design Guidelines for Historic Districts and
Landmark Sites

All Participants around Salt Lake City

there's plaza building on state and about 1360 south need electrical drawn up and upper south section!

he put up some aromier cable! i think it needs some tubing for 15 amp(s) circuits.

i left a paper for a rough schetch, plus left samples with mike dad, the owner of the choachman's, the tile, can be got at r.c. willey! but don't know, if one color, is going to be enough! maybe combo and thiers a roll of carpet theier also! left samples I gave my perfernce!

they can stock ski up there for out of towner's. i dont know it prety roomy!

need some one with a computer screen big enough to draw plans! i guess, also check sewer!

craig n hendricks

Name not shown in District 3

November 25, 2011, 9:13 PM

I have wanted to improve my home in a historic district in three main ways. The first is to improve the seismic (earthquake) stability. The second is to insulate the walls which are only brick and plaster. The third is to replace rotten wood single pane windows.

It seems that the only cost-effective methods for achieving these goals are not allowed. For example, if the outside of a brick structure could be insulated and covered with siding or stucco, the seismic improvements could happen on the outside as well. This would preserve the livability of the structure by maintaining the interior square footage.

We need to be able to live in safe and warm homes. If energy prices rise, or if there is an earthquake, what good will any of these "correctly restored" homes be to our community?

Name not shown in District 6

November 23, 2011, 11:24 AM

I support whatever will stop demolition and insensitive remodeling of Salt Lake's historic homes. Folks desiring to alter historic homes need to consider the negative impact on their neighbors' property values (nobody wants to live adjacent to a poorly done replacement home), views, privacy, inconvenience during construction, etc. They should also consider the impact of their project on future parking and traffic patterns in the neighborhood. People who prefer large structures made from inexpensive materials should live in neighborhoods where that exists -- there are plenty south of Salt Lake. Such people should not be allowed to destroy the quality and character of our valuable historic homes and neighborhoods.

Wayne Andersen in District 3

November 23, 2011, 8:41 AM

Rather than comment on all of the guidelines, I'll focus on two of the general statements:

1) Preservation: Preserve any existing original site features or original building materials and features.

Preserve original site features such as grading, rock walls, etc. Avoid removing or altering original

Revisions to the Residential Design Guidelines for Historic Districts and Landmark Sites

What are your opinions about the proposed changes?

All Participants around Salt Lake City

materials and features. Preserve original doors, windows, porches and other architectural features. Repair deteriorated historic features and replace only those elements that cannot be repaired.

2) Restoration: Upgrade existing materials and elements, using recognized preservation methods whenever possible. If disassembly is necessary for repair or restoration, use methods that minimize damage to original materials and replace the original configuration.

Last year we applied to replace 3 double hung single pane wood sash windows. We were told that given the location of the windows they could be replaced with new double hung double pane wood sash windows. We asked about windows facing the street, and were told they'd have to be rebuilt with existing materials. Point is that removing, rebuilding, and repairing energy inefficient windows does not make any sense. I've seen people get away with putting in non wood windows that are energy efficient (your inspectors don't catch these non-conforming owners). At a distance, one cannot tell the difference between a repaired original window, a conforming wood sash window, or a non-conforming vinyl window. In addition, those homes in the historic area that have been chopped into apartments seem to be exempt from any historical conformity. Preservation is highly subjective and the city has the posture of erring on the side of strict preservation which makes it costly and difficult for a home owner to maintain or improve the energy efficiency of their home.

Think about it -- Deteriorated windows -- Preserve the materials and rebuild the windows. Remove the windows -- Hole in the home for how long? Rebuild and repair and re-glaze (hopefully with more efficient glass), repaint, and re-install takes time (I assume a couple of weeks) Most window replacements are done in less than a day.

My recommendation is to soften the content and allow the homeowner to partner with the city in working out what is best for the property on a case by case basis allowing for alternative materials which maintain the historical look to the property. The Historical Society deems various levels of historical significance to a property which also could be considered. If a property is of great historical significance, then that partnering would lean more towards preservation and restoration while a property of little historical significance would be allowed the 'look' without the stringent requirements of preservation and restoration.
