

Attachment I

Yalecrest Preservationists for Property Rights – Submission



Zoning Amendment

OFFICE USE ONLY
 Petition No.: PLNPCM2010-00467
 Date Received: 10/6/10
 Reviewer: RECEIVED

- Amend the text of the Zoning Ordinance by amending Section: 21A.34.120 and 21A.34.020
- Amend the Zoning Map by reclassifying the above property from a zone to a zone. (attach map or legal description)

OCT 6 2010

BY: JA

SALT LAKE CITY PLANNING

Address of Subject Property: Yalecrest Infill Overlay Dist. (SLCC§ 21A.34.120(B))

Name of Applicant: Yalecrest Preservationists Phone: (801) 415-3000
for Property Rights (Attn: Jodi Howick)

Address of Applicant: 111 E. Broadway Suite 900 P.O. Box 4050, SLC, UT 84110

E-mail Address of Applicant: jhowick@djplaw.com Cell/Fax: (801) 415-3500
and bwinches@us.ibm.com

Applicant's Interest in Subject Property: YCPPR is a group of homeowners residing within the Yalecrest Infill Overlay District.

Name of Property Owner: Ben Winchester, Co-Chair of Phone: (801) 201-1198
Yalecrest Preservationists for Property Rights

E-mail Address of Property Owner: bwinches@us.ibm.com Cell/Fax: (801) 201-1198

County Tax ("Sidwell #"): All areas within overlay district. Zoning R-1/5,000, R-1/7,000, and YCI Yalecrest Compatible Infill

Legal Description (if different than tax parcel number): Overlay District
See Above

Existing Property Use:		Proposed Property Use:
<u>N/A</u>		<u>N/A</u>

Please include with the application:

- 1. A statement of the text amendment or map amendment describing the purpose for the amendment and the exact language, boundaries and zoning district.
- 2. A complete description of the proposed use of the property where appropriate.
- 3. Reasons why the present zoning may not be appropriate for the area.
- 4. **The cost of first class postage for each address within 300 feet is due at time of application. Please do not provide postage stamps. (Mailing labels can be generated through the Buzz Center at time of application)**
- 5. Legal description of the property.
- 6. Six (6) copies of site plans drawn to scale and one (1) 11 x 17 inch reduced copy of each plan and elevation drawing.
- 7. If applicable, a signed, notarized statement of consent from property owner authorizing applicant to act as agent
- 8. **Filing fee of \$885.92, plus \$110.74 for each acre over one acre and the cost of first class postage is due at time of application.**

Notice: Additional information may be required by the project planner to ensure adequate information is provided for staff analysis.
All information submitted as part of the application may be copied and made public including professional architectural or engineering drawings which will be made available to decision makers, public and any interested party.

File the complete application at:
Salt Lake City Buzz Center
PO Box 145471
451 South State Street, Room 215,
Salt Lake City, UT 84114
(801) 535-7700

Signature of Owner or Agent [Signature] Date 6 Oct 2010

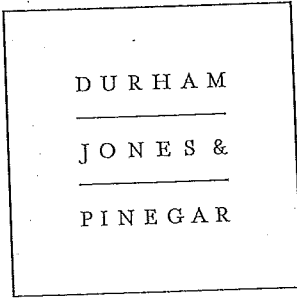

DURHAM JONES & PINEGAR, P.C.
111 East Broadway, Suite 900
P O Box 4050
Salt Lake City, Utah 84110
801.415.3000
801.415.3500 Fax
www.djplaw.com

Jodi L. Howick
Attorney at Law
jhowick@djplaw.com

October 6, 2010

Planning Commission
Salt Lake City Corporation
451 South State, Room 326
Salt Lake City, UT 84110

Dear Commission Members:

The Yalecrest Preservationists for Property Rights (YCPPR) is submitting to Salt Lake City the enclosed application to amend the text of Salt Lake City Code Sections 21A.34.120 and 21A.34.020. YCPPR is a group of neighbors who live within the area of the Yalecrest compatible infill overlay district, and I am forwarding this submission on their behalf.

YCPPR believes the present zoning may not be appropriate for the area included within the overlay district. The City created the overlay district several years ago to promote "a desirable residential neighborhood by maintaining aesthetically pleasing environments, safety, privacy, and neighborhood character" and to use "flexibility of design while providing compatibility with existing development patterns within the Yalecrest community." Salt Lake City Code § 21A.34.120 (A). The ordinance currently pursues these goals primarily by limiting the height of buildings and placing restrictions on accessory structures. However the ordinance does not address promoting the aesthetic qualities that are important to many Yalecrest residents.

YCPPR is submitting this application to amend the Yalecrest overlay district (Section 21A.34.120) to include provisions that will help property owners promote its aesthetic goals. The proposed changes would add requirements in the overlay ordinance for side yards in addition to those for building height, front yards, and garages to better address the size and scale of homes in the district. In recent meetings conducted by the City in the overlay district, residents expressed strong support for preventing oversized homes in the area (these records are in the City's possession, and a summary of the City's survey is attached to this letter). The proposed side yard requirements focus on maintaining compatible dimensions consistent with the purposes of the ordinance.

The proposed changes would also create a voluntary character preservation program, a purely voluntary program that would provide resources to property owners in the form

of design guidelines and a design database tailored to the neighborhood, a voluntary review board that would be available to offer non-binding design information and recommendations, and voluntary programs such as to provide education, community awards and recognition, and participation incentives. This program addresses the ordinance's goal to promote neighborhood aesthetics, which the ordinance currently does not address. The program is designed to allow the community to establish and pursue its own aesthetic values consistent with the flexible goals of the ordinance.

By proposing this voluntary program under the infill ordinance, YCPPR seeks to build on the intent that the community established in the ordinance and benefit Yalecrest property owners in a variety of ways. Among them:

Voluntary design guidelines can be tailored by the neighborhood. The proposed changes will allow the community to create its own aesthetic guidelines based on features within the existing neighborhood, consistent with the infill ordinance's goal to provide for flexibility of compatible design. By contrast, other tools to preserve character or historic accuracy impose restrictions based on broad, external standards that are not tailored to the neighborhood.

Design reviews, guidelines, and databases will provide personalized resources. Property owners will be able to obtain feedback specific to their homes about how they can enhance the neighborhood's character on a voluntary basis. This is also consistent with the ordinance's goal of flexibility. This voluntary feedback cannot be used in other City processes under the proposed program, and so owners need not fear that participating in the process could be used against them.

The voluntary processes are clear and streamlined. They offer a fast, simple method for obtaining feedback about how properties can contribute to the neighborhood's character. This will encourage owners to use these processes, since their plans will not be slowed by bureaucratic requirements.

Property owners will remain in control of their homes. The ordinance that the neighborhood approved encourages both compatibility and flexibility, and those goals cannot be met if the City dictates aesthetic decisions through rigid regulations. The proposed voluntary measures instead encourage property owners to contribute to the beauty of the neighborhood by facilitating their ability to do so.

Residents and builders will become more familiar with designs that enhance the neighborhood. Under any set of regulations, renovations and tear-downs will still be possible. These voluntary measures will allow residents and builders to incorporate the neighborhood's design features at an early stage, when planning is cost effective, without concerns for costly second-guessing by regulators later

on. These resources make participation more likely, consistent with the goals of the ordinance.

Voluntary measures are cost effective. Property owners can design their homes to address character overall rather than being forced to implement numerous individual restrictions. This will allow owners to work within their budgets, consistent with the ordinance's goal of flexibility. Voluntary measures will also mitigate the need for additional insurance costs that many insurance companies require in order to cover rebuilding homes to historically accurate requirements.

Voluntary measures allow the neighborhood to grow and maintain vibrancy. Housing needs change as lifestyle needs change, and voluntary measures allow families to preserve the neighborhood's character while accommodating changing needs and planning for the future. These measures will also maintain economic vibrancy. Currently realtors working in this neighborhood have reported that potential buyers have reacted adversely to the prospect of an historic district. Voluntary measures will create an environment of cooperation that will protect a homeowner's investment in the neighborhood.

Voluntary measures avoid disputes that are divisive to the community and to the City. Imposed standards inevitably lead to disagreements within the community, and documentation on file with the City regarding recent efforts to impose an historic district in the Yalecrest neighborhood reflects strong divisions. Disagreements can also lead to disputes when the City tries to apply imposed standards, such as through appeal processes or petitions to the state ombudsman. Voluntary guidelines provide resources that are flexible and cooperative consistent with the goals of the infill ordinance, and they support the Yalecrest neighborhood's long tradition of community involvement and positive relationships.

The community supports voluntary measures. During recent City-conducted meetings, a strong majority of residents supported protecting the neighborhood without imposing restrictive regulatory mandates (a summary of comments is attached). The participatory nature of the proposed changes will unite the community around its common values, and as a voluntary program, these measures do not raise the legal questions that might arise under imposed standards and can be implemented through the City's ordinary processes.

Incentives that may be created under the proposed changes will further enhance the effectiveness of the voluntary program and further the goals of the infill ordinance. Residents will be able to benefit by contributing to the neighborhood's character, and neighborhood awards and recognition will be available to honor outstanding efforts.

YCPPR believes that the proposed changes submitted with this application are the right tool to promote the character of the neighborhood and the goals of the infill ordinance. The City is currently contemplating whether to pursue other tools (specifically, by imposing an historic district), and that discussion to date has proven to be highly controversial in the neighborhood. We are also aware that the state legislature is considering placing limits on tools such as historic districts because of their severe impacts to the rights of property owners, and that the legislature has supported property rights in other recent legislation.

YCPPR has proposed changes to Salt Lake City Code § 21A.34.020 to better establish how historic districts may be pursued, protect against aggressive efforts within neighborhoods, and avoid measures that interfere with the Yalecrest overlay district. These proposed changes better define what areas may be included in an historic district proposal. They also establish procedural requirements for such a proposal; property owners must receive advance notice of an historic district proposal, the period during which owners may be solicited to support such a proposal is limited, and the proposal must receive a significant level of verifiable support before it can be submitted to the City for consideration. If a proposal does not succeed, the neighborhood will be allowed a rest period before the issue of an historic district can be raised again in order to preserve the neighborhood environment. Such a rest period is also consistent with state requirements regarding the use of temporary zoning measures when communities do not support the measures. (See Utah Code Ann. § 10-9a-504.)

Recent efforts to impose historic district measures in the Yalecrest neighborhood were not successful during the period when the City Council imposed temporary zoning regulations and sought to create such a district. This raises concerns under the requirements of Utah Code Ann. § 10-9a-504 and Salt Lake City Code § 21A.50.060. Additionally, imposing such a district on the Yalecrest neighborhood is not supportable under YCPPR's application to change Sections 21A.34.120 and 21A.34.020. Such a mandate would render meaningless YCPPR's proposal and the substance of the infill ordinance.

The City cannot pursue the current discussion to designate an historic district due to the requirements of Utah Code Ann. § 10-9a-509(1)(a)(ii). That ordinance provides that a land use application cannot be approved if, before the application is submitted, the City has formally initiated proceedings to amend its ordinances in a manner that would prohibit approval of the application. The pending discussion before the Historic Landmark Commission is not a submitted application, and by accepting the enclosed application the City has now formally initiated a proceeding to amend the Yalecrest infill ordinance. These measures are a proceeding that prohibits approval of an historic district in this area. We therefore request that the City discontinue any consideration of proposals to create an historic district in the Yalecrest neighborhood and proceed with consideration of this application. We further request that the City's process include community meetings to discuss these measures with the Yalecrest neighborhood.

Planning Commission
October 6, 2010
Page 5

We would be happy to provide additional information regarding YCPPR's proposal, how it addresses concerns in the Yalecrest neighborhood, and how it supports the goals of the infill ordinance. Please feel free to contact me with any questions you may have. YCPPR looks forward to the community discussions that can now take place to consider appropriate tools to address the values of the Yalecrest neighborhood.

Very truly yours

DURHAM JONES & PINEGAR, P.C.

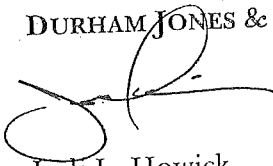

Jodi L. Howick

JH/cm

cc: Ben Winchester, Co-chair, Yalecrest Preservationists for Property Rights
Susan Hansen Porter, Co-chair, Yalecrest Preservationists for Property Rights

Do you feel that the City Council's approval of the Temporary zoning ordinance:

1. Caused residents to question the City's motives?
2. Was necessary in order to avoid tear-downs until a Historic District could be considered?
3. Was done secretly?
4. Was a chance to call a 6 month time out to determine the neighborhood's future?

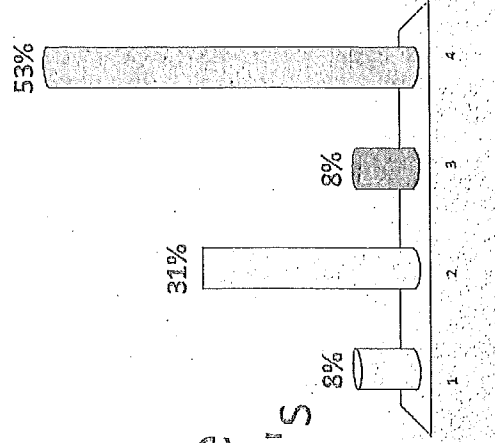

The following pages contain unofficial data results received during the four community meetings regarding the proposed Local Yalecrest Historic District. Questions given were not scientific, professionally formulated, or intended to constitute a vote. The results in the document are not indicative of a vote or a final decision and only represent a small portion of the entire area; the results are to gain general insight from the participating residents.

What characteristics of the neighborhood made you choose to live in Yalecrest?

1. architecture
2. location
3. schools
4. neighbors
5. historic character
6. potential home value

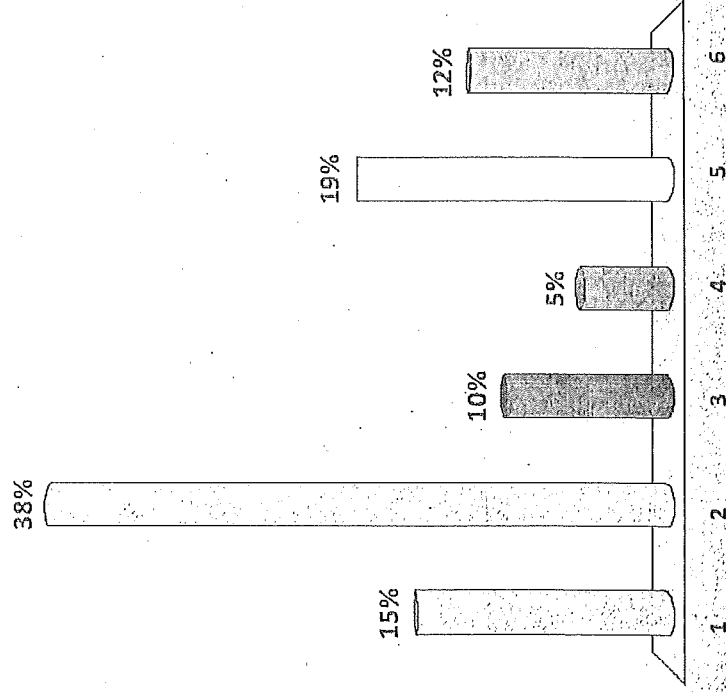

The following pages contain unofficial data results received during the four community meetings regarding the proposed Local Yalecrest Historic District. Questions given were not scientific, professionally formulated, or intended to constitute a vote. The results in the document are not indicative of a vote or a final decision and only represent a small portion of the entire area; the results are to gain general insight from the participating residents.

What is the appropriate balance for the neighborhood?

1. Individuals can do what they want with their property
2. Preserving the neighborhood character
3. Preventing any demolitions

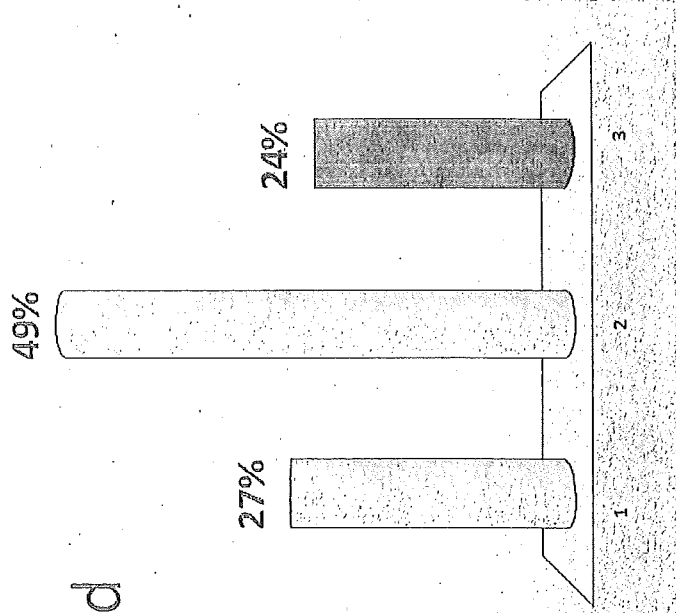

The following pages contain unofficial data results received during the four community meetings regarding the proposed Local Yalecrest Historic District. Questions given were not scientific, professionally formulated, or intended to constitute a vote. The results in the document are not indicative of a vote or a final decision and only represent a small portion of the entire area; the results are to gain general insight from the participating residents.

Which issue are you most concerned about?

1. Preservation of existing structures
2. Compatibility of structures in the neighborhood
3. Size of structures

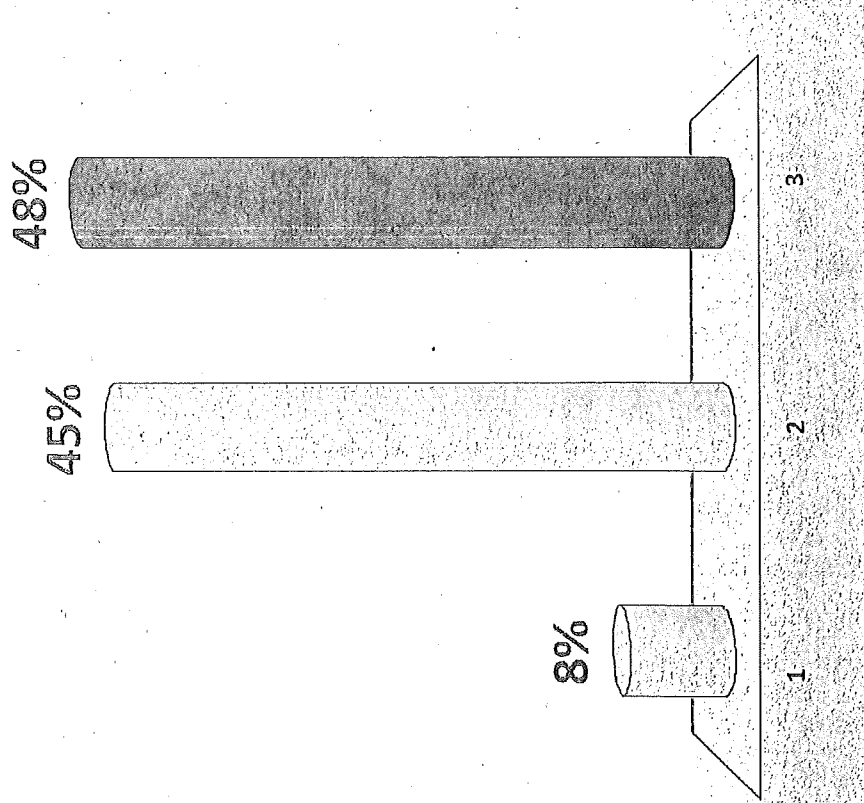

The following pages contain unofficial data results received during the four community meetings regarding the proposed Local Yalecrest Historic District. Questions given were not scientific, professionally formulated, or intended to constitute a vote. The results in the document are not indicative of a vote or a final decision and only represent a small portion of the entire area; the results are to gain general insight from the participating residents.

Which colors can you paint your home under Local Historic District regulations?

1. Red
2. Green
3. Brown
4. Gray
5. There is no restriction

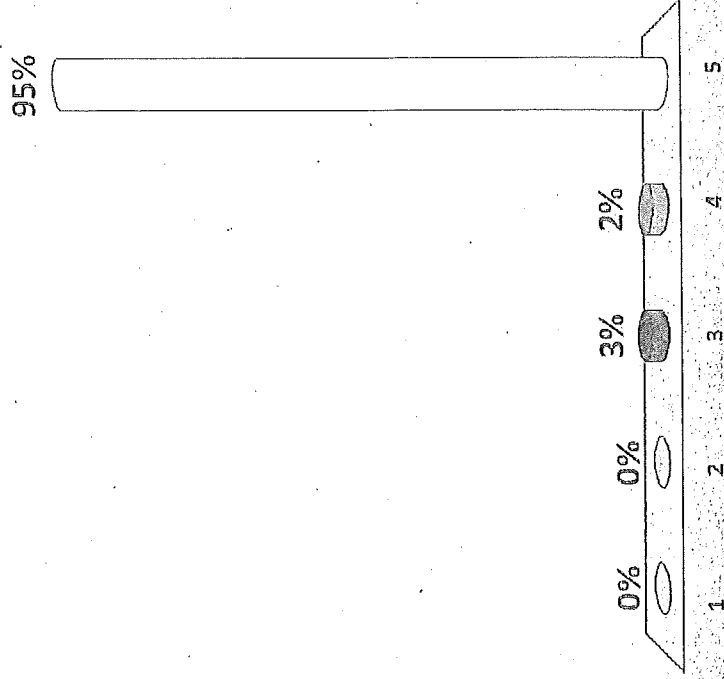

The following pages contain unofficial data results received during the four community meetings regarding the proposed Local Yalecrest Historic District. Questions given were not scientific, professionally formulated, or intended to constitute a vote. The results in the document are not indicative of a vote or a final decision and only represent a small portion of the entire area; the results are to gain general insight from the participating residents.

Additions are not allowed under Local Historic District regulations.

1. True
2. False

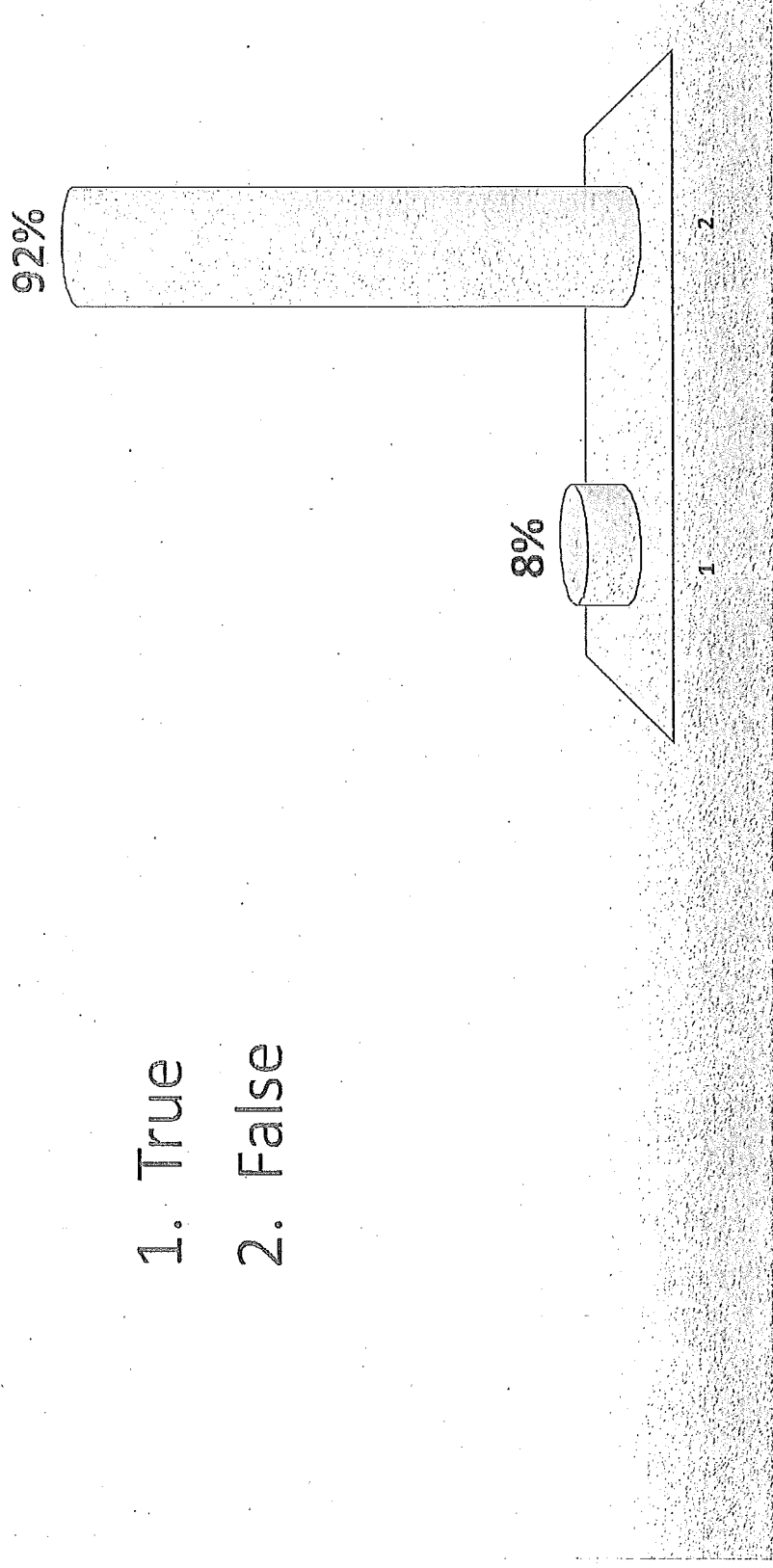

The following pages contain unofficial data results received during the four community meetings regarding the proposed Local Yalecrest Historic District. Questions given were not scientific, professionally formulated, or intended to constitute a vote. The results in the document are not indicative of a vote or a final decision and only represent a small portion of the entire area; the results are to gain general insight from the participating residents.

Do you feel like you have enough information to have a firm opinion on whether you would like to have a historic district or not?

1. Yes
2. No

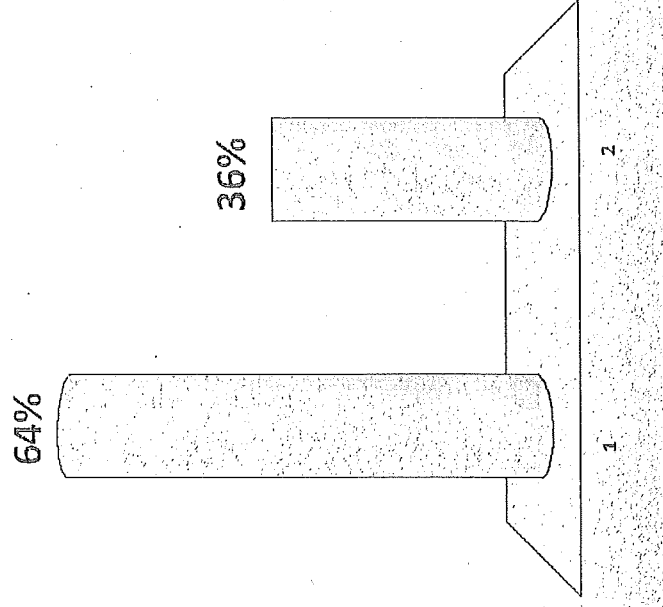

The following pages contain unofficial data results received during the four community meetings regarding the proposed Local Yalecrest Historic District. Questions given were not scientific, professionally formulated, or intended to constitute a vote. The results in the document are not indicative of a vote or a final decision and only represent a small portion of the entire area; the results are to gain general insight from the participating residents.

Have you expressed a 'yes' or 'no' opinion through one of the web sites or by contacting the City Council?

1. Yes
2. No

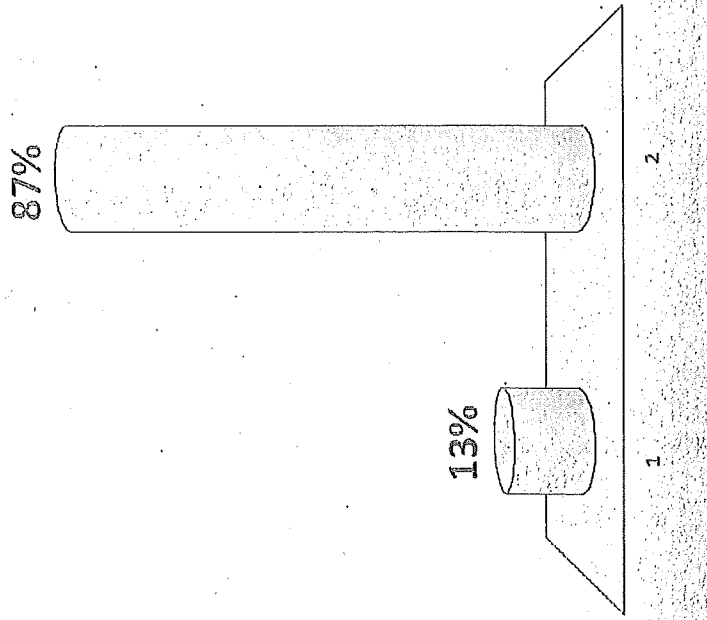

The following pages contain unofficial data results received during the four community meetings regarding the proposed Local Yalecrest Historic District. Questions given were not scientific, professionally formulated, or intended to constitute a vote. The results in the document are not indicative of a vote or a final decision and only represent a small portion of the entire area; the results are to gain general insight from the participating residents.

If you have expressed a 'yes' or 'no' opinion do you now feel like you fully understood the issue when you expressed that position?

- 1. Yes
- 2. No

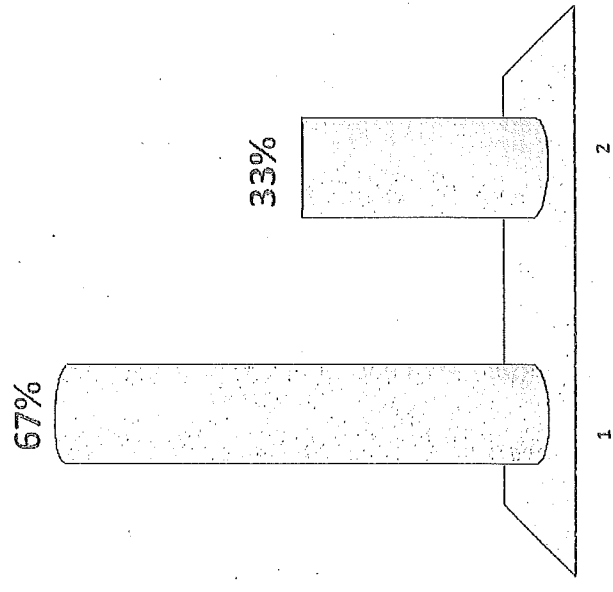

The following pages contain unofficial data results received during the four community meetings regarding the proposed Local Yalecrest Historic District. Questions given were not scientific, professionally formulated, or intended to constitute a vote. The results in the document are not indicative of a vote or a final decision and only represent a small portion of the entire area; the results are to gain general insight from the participating residents.

If you have submitted your opinion to the Council Office, has your opinion changed since then?

1. Yes
2. No

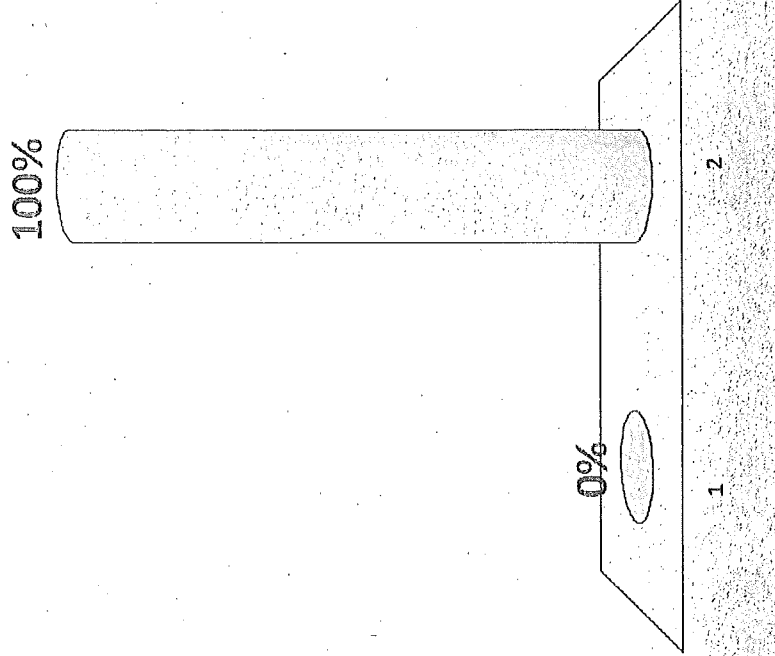

The following pages contain unofficial data results received during the four community meetings regarding the proposed Local Yalecrest Historic District. Questions given were not scientific, professionally formulated, or intended to constitute a vote. The results in the document are not indicative of a vote or a final decision and only represent a small portion of the entire area; the results are to gain general insight from the participating residents.

Most of the concerns in the neighborhood are demolitions & remodels that push the limits of current law & disregard the style & scale of the neighborhood.

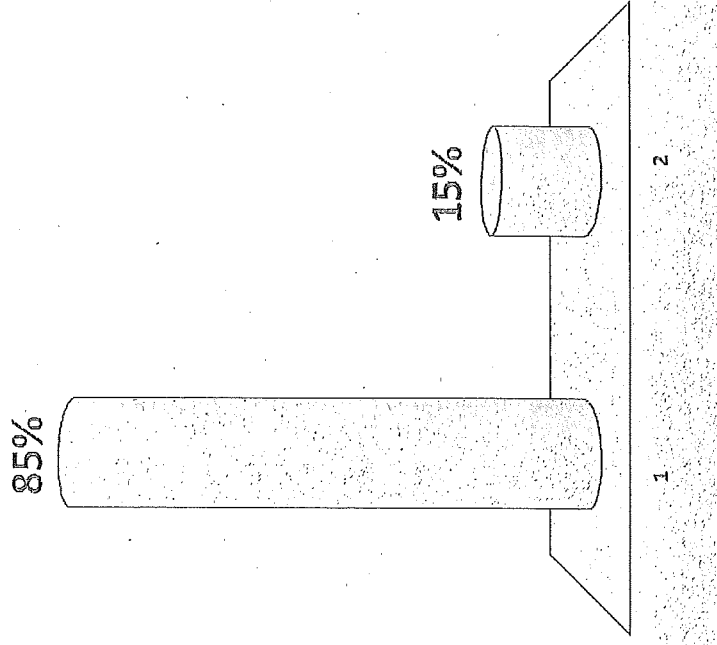

- 1. Agree
- 2. Disagree

The following pages contain unofficial data results received during the four community meetings regarding the proposed Local Yalecrest Historic District. Questions given were not scientific, professionally formulated, or intended to constitute a vote. The results in the document are not indicative of a vote or a final decision and only represent a small portion of the entire area; the results are to gain general insight from the participating residents.

If historic designation is made, the review process needs to be sped up.

- 1. Agree
- 2. Disagree

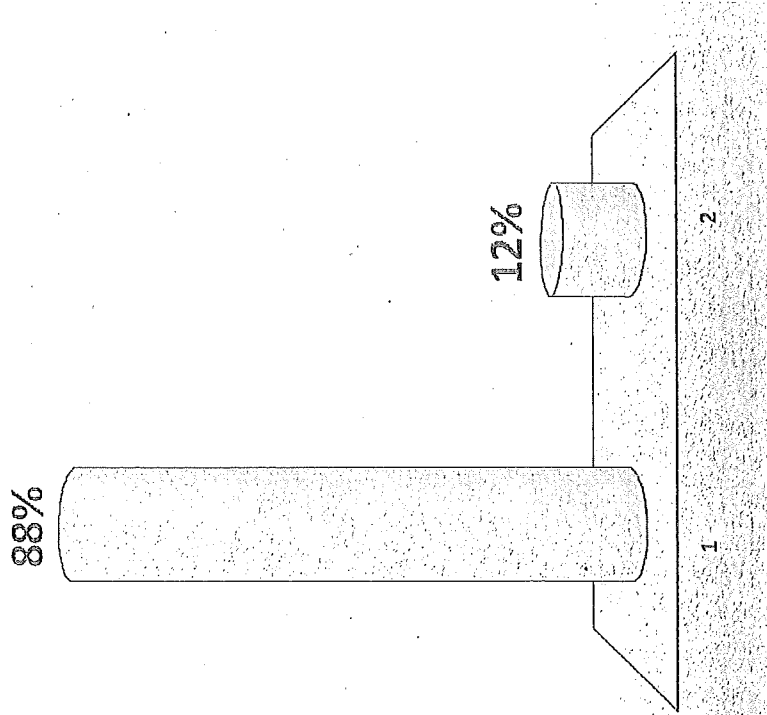

The following pages contain unofficial data results received during the four community meetings regarding the proposed Local Yalecrest Historic District. Questions given were not scientific, professionally formulated, or intended to constitute a vote. The results in the document are not indicative of a vote or a final decision and only represent a small portion of the entire area; the results are to gain general insight from the participating residents.

APPLICATION TO AMEND
SALT LAKE CITY CODE §§ 21A.34.120 AND 21A.34.020

The text of the proposed amendments to these ordinances is shown double underlined below.

21A.34.120: YCI YALECREST COMPATIBLE INFILL OVERLAY DISTRICT:

A. Purpose Statement: The purpose of the Yalecrest compatible infill (YCI) overlay district is to establish standards for new construction, additions and alterations of principal and accessory residential structures within the Yalecrest community. The goal is to encourage compatibility between new construction, additions or alterations and the existing character and scale of the surrounding neighborhood. The YCI overlay district promotes a desirable residential neighborhood by maintaining aesthetically pleasing environments, safety, privacy, and neighborhood character. The standards allow for flexibility of design while providing compatibility with existing development patterns within the Yalecrest community.

B. Overlay District Boundary: The YCI overlay district applies to any residential property zoned residential R-1/5000 or R-1/7000 within the area defined by the intersecting centerlines of 1300 East, 800 South, Sunnyside Avenue (840 South), 1900 East and 1300 South Streets.

C. Building Height and Scale:

1. Maximum Building Height: All heights to be measured from finish grade.
 - a. Pitched roofs: Twenty seven and one-half feet (27.5') measured to the midpoint of the roof (as indicated in section 21A.62.050, illustration B, of this title).
 - b. Mansard or flat roofs: Twenty feet (20').
 - c. Lots with cross slopes where the topography slopes from one side property line to the other side or corner side property line may increase the maximum building height, as measured from the downhill side face of the building at a rate of one-half foot (0.5') for each one foot (1') difference between average grades of the uphill and downhill faces of the building, up to a maximum height of thirty feet (30').
2. Maximum Exterior Wall Height Adjacent To Interior Side Yards: Eighteen and one-half feet (18.5') for exterior walls placed at the building setback established by the

minimum required yard. Exterior wall height may increase one foot (1') (or fraction thereof) in height for each foot (or fraction thereof) of increased setback beyond the minimum required interior side yard. If an exterior wall is approved with a reduced setback through a special exception, variance or other process, the maximum allowable exterior wall height decreases by one foot (1') (or fraction thereof) for each foot (or fraction thereof) that the wall is located closer to the property line than the required side yard setback.

a. Lots With Cross Slopes: Lots with cross slopes where the topography slopes from one side property line to the other side or corner side property line, the downhill exterior wall height may be increased by one-half foot (0.5') for each one foot (1') difference between the elevation of the average grades on the uphill and downhill faces of the building.

b. Exceptions:

(1) Gable Walls: Walls at the end of a pitched roof may extend to a height necessary to support the roof structure except that the height of the top of the widest portion of the gable wall must conform to the maximum wall height limitation described in this section.

(2) Dormer Walls: Dormer walls are exempt from the maximum exterior wall height if:

(A) The width of a dormer is ten feet (10') or less; and

(B) The total combined width of dormers is less than equal to fifty percent (50%) of the length of the building facade facing the interior side yard; and

(C) Dormers spaced at least eighteen inches (18") apart.

3. Maximum Building Scale: The scale of the building shall be limited by at least one of the following requirements:

a. Side Yard Percentage: The total minimum side yard shall be equal to the average of the smallest fifty percent (50%) of side yards measured. For example, if ten (10) developed properties are located along the same side of the street within three hundred feet (300') of the subject property, the total required minimum side yard is equal to the average of the five (5) ($10 \times 50\% = 5$) smallest side yards; or

b. Existing Wall: The original length of one wall of the building shall be maintained.

D. Front Yard Requirements: The minimum front yard shall be derived by measuring the front yards (the open, unoccupied, landscaped space between the front building lines of all developed properties) fronting the same side of the street within three hundred feet (300') of the subject property but in no case shall the measurements extend across intervening streets. The minimum required front yard shall be equal to the average of the

smallest fifty percent (50%) of front yards measured. For example, if ten (10) developed properties are located along the same side of the street within three hundred feet (300') of the subject property, the required minimum front yard is equal to the average of the five (5) (10 x 50% = 5) smallest front yards.

E. Accessory Structures:

1. Maximum Height For Accessory Structures With A Pitched Roof: Fifteen feet (15').
2. Noncomplying Detached Garages: An existing noncomplying detached garage located in the rear yard may be rebuilt or expanded at its existing location to a maximum size of four hundred forty (440) square feet subject to the approval of the development review team (DRT).
3. Garages Located In Front Of The House: No detached garage shall be constructed forward of the "front line of the building" (as defined in section 21A.62.040 of this title), unless a new garage is constructed to replace an existing garage. In this case, the new garage shall be constructed in the same location with the same dimensions as the garage being replaced.
4. Maximum Garage Door Height: Eight and one-half feet (8.5').

F. Standards For Attached Garages:

1. Located Behind Or In Line With The Front Line Of The Building: No attached garage shall be constructed forward of the "front line of the building" (as defined in section 21A.62.040 of this title), unless a new garage is constructed to replace an existing garage. In this case, the new garage shall be constructed in the same location with the same dimensions as the garage being replaced.
2. Width Of An Attached Garage: The width of an attached garage facing the street may not exceed fifty percent (50%) of the width of the front facade of the house. The width of the garage is equal to the width of the garage door, or in the case of multiple garage doors, the sum of the widths of each garage door plus the width of any intervening wall elements between garage doors up to a maximum of three feet (3').
3. Maximum Garage Door Height: Eight and one-half feet (8.5').

G. Special Exception For Garages: A garage built into a hillside and located forward of the front line of the building may be allowed as a special exception granted by the board of adjustment, subject to the following standards:

1. The rear and side yards cannot be reasonably accessed for the purpose of parking.
2. Because of the topography of the lot it is impossible to construct a garage and satisfy the standards of the YCI.
3. The ceiling elevation of the garage is below the elevation of the first or main floor of the house.
4. The garage meets all applicable yard requirements.

H. Yalecrest Voluntary Character Preservation Program. The purpose of the Yalecrest voluntary character preservation program is to provide a voluntary, nonbinding resource to property owners within the overlay district to promote the purposes of the overlay district on a cooperative basis. Property owners within the Yalecrest compatible infill overlay district may participate in the following voluntary measures:

1. Yalecrest Character Review Board. The Yalecrest character review board is created to promote aesthetic character and preservation within the overlay district using voluntary measures.

a. Board Authority. The Yalecrest character review board is authorized to create and maintain Yalecrest design guidelines and a design database in the manner provided in this subparagraph H; provide voluntary design reviews and recommendations to property owners; and promote education, conduct award and recognition programs, and provide for other voluntary resources and programs to promote aesthetic character and preservation within the overlay district.

b. Creation of Board. The Yalecrest character review board shall consist of seven (7) members appointed by the mayor, with the advice and consent of the city council, which shall include four (4) property owners residing within the overlay district and three (3) architects, planners, or other design professionals with technical expertise in building aesthetics who do not reside within the overlay district. The director of the planning division (or the planning director's designated representative) shall serve as an ex officio member without the power to vote or make recommendations. Appointed members of the board may serve a maximum of two (2) consecutive full terms of two (2) years each. The terms shall be staggered such that no more than three (3) members are appointed each year. The mayor shall appoint a new board member to fill any vacancy that might arise, and such appointment shall not be included in the determination of any person's eligibility to serve two (2) consecutive full terms.

c. Officers: The Yalecrest character review board shall annually elect a chair and a vice chair who shall serve for a term of one year each. The chair or vice chair may be elected to serve consecutive terms in the same office. A secretary shall be designated by the planning director.

d. Removal Of A Member: Any member of the Yalecrest character review board may be removed by the mayor for violation of this title or any policies and procedures adopted by the board following receipt by the mayor of a written complaint filed against the member. If requested by the member, the mayor shall provide the member with a public hearing conducted by a hearing officer appointed by the mayor.

e. Policies And Procedures: The Yalecrest character review board may adopt reasonable policies and procedures not inconsistent with this title for the conduct of its meetings, the voluntary review of proposed designs, and for any other purposes considered necessary for its proper functioning.

f. Meetings: The Yalecrest character review board shall meet periodically as needed to conduct the business of the board. Meetings shall be open to the public, and the board shall keep a record of board votes and may keep a record of recommendations to property owners.

g. Quorum And Vote: No business shall be conducted at a meeting of the Yalecrest character review board without a quorum. A majority of the voting members of the board constitutes a quorum. All actions of the board shall be represented by a vote of the membership. A simple majority of the voting members present at a meeting at which a quorum is present shall be required for any action taken, except that at least one member of such majority shall be a non-resident member of the board. The board shall conduct voting to implement programs and take other actions over which the board has administrative authority. A quorum must be present when the board makes recommendations to property owners, but the board shall not vote on such recommendations and any board member may offer recommendations, whether verbal or written. All such recommendations shall be informational and non-binding, and they shall not be used in connection with any city process.

h. Conflicts Of Interest: No member of the Yalecrest character review board shall participate in any matter in which that member has a conflict of interest prohibited by title 2, chapter 2.44 of this code.

2. Design Guidelines and Database. The Yalecrest character review board shall create design guidelines and a design database to provide examples to residents of desirable architectural features that promote the character, aesthetic qualities, and historic nature of the overlay district. Any property owner within the overlay district may at any time submit information to the board to be considered for inclusion in the guidelines or the database. Information may only become a part of the guidelines or the database by a vote of the board. The design database shall include both photographs and text demonstrating architectural features, and it shall be made available to the public electronically.

3. Voluntary Design Review and Recommendations. Any property owner within the overlay district may obtain a voluntary design review of proposed development plans from the Yalecrest character review board. When conducting this review, the board may make recommendations and provide information to the property owner regarding how the proposed design can incorporate architectural and other design features that promote the character, aesthetic qualities, and historic nature of the overlay district based on the board's design guidelines and design database, and in light of cost factors, physical constraints, the location of the property, and other objective factors. Property owners within the overlay district may request this design review by making a written request to the zoning administrator, and the board shall provide its review and recommendations within no more than forty-five (45) days of the written request. Recommendations may be verbal or in writing. The board's recommendations and information are provided strictly as a voluntary, non-binding resource to the property owner. Such recommendations and information shall not be submitted to the city in any manner, and the city shall not consider any such recommendations or information in any manner, whether in connection with the planning commission, city council, or otherwise.

4. Education, Awards, and Promotional Activities. The Yalecrest character review board may create and implement voluntary programs to promote the goals of the overlay district, including, but not limited to, award and recognition programs for property owners and designers, neighborhood tours, and educational courses and seminars on design methods. The board may conduct fundraising activities, and such funds shall be maintained by the city in accordance with city procedures. If the board adopts an incentive program, the city may provide incentives to applicants who voluntarily incorporate the board's recommendations in the form of reduced permit fees, but the total of all such permit fee reductions shall not exceed fifty percent (50%). Any incentive program must be acceptable to the City Attorney's Office.

I. Authority To Modify Regulations Through Variance Or Special Exception: The board of adjustment may consider applications from property owners seeking to change, alter, modify or waive any provisions of this section or other regulations applicable to the district in which the subject property is located through the variance (chapter 21A.18 of this title) or special exception (chapter 21A.52 of this title) processes. No such change, alteration, modification or waiver shall be approved unless the board of adjustment finds that the proposal:

1. Will achieve the purposes of the Yalecrest compatible infill overlay district described in subsection A of this section; and
2. Will not violate the general purposes, goals and objectives of this title and of any plans adopted by the city. (Ord. 44-05 § 1, 2005)

21A.34.020: H HISTORIC PRESERVATION OVERLAY DISTRICT:

A. Purpose Statement: In order to contribute to the welfare, prosperity and education of the people of Salt Lake City, the purpose of the H historic preservation overlay district is to:

1. Provide the means to protect and preserve areas of the city and individual structures and sites having historic, architectural or cultural significance;
2. Encourage new development, redevelopment and the subdivision of lots in historic districts that is compatible with the character of existing development of historic districts or individual landmarks;
3. Abate the destruction and demolition of historic structures;
4. Implement adopted plans of the city related to historic preservation;
5. Foster civic pride in the history of Salt Lake City;
6. Protect and enhance the attraction of the city's historic landmarks and districts for tourists and visitors; and
7. Foster economic development consistent with historic preservation.

B. Definitions:

1. H Historic Preservation Overlay District: A geographically or thematically definable area which contains buildings, structures, sites, objects, landscape features, archeological sites and works of art, or a combination thereof, that contribute to the historic preservation goals of Salt Lake City.
2. Contributing Structure: A contributing structure is a structure or site within an H historic preservation overlay district that meets the criteria outlined in subsection C2 of this section and is of moderate importance to the city, state, region or nation because it imparts artistic, historic or cultural values. A contributing structure has its major character defining features intact and although minor alterations may have occurred they are generally reversible. Historic materials may have been covered but evidence indicates they are intact.
3. Noncontributing Structure: A noncontributing structure is a structure within an H historic preservation overlay district that does not meet the criteria listed in subsection C2 of this section. The major character defining features have been so altered as to make the original and/or historic form, materials and details indistinguishable and alterations are

irreversible. Noncontributing structures also include those which are less than fifty (50) years old.

4. Landmark Site: A landmark site is any site included on the Salt Lake City register of cultural resources that meets the criteria outlined in subsection C2 of this section. Such sites are of exceptional importance to the city, state, region or nation and impart high artistic, historic or cultural values. A landmark site clearly conveys a sense of time and place and enables the public to interpret the historic character of the site.

5. New Construction: The building of a new principal structure on a lot or property within an H historic preservation overlay district or on a landmark site.

6. Demolition: Any act or process which destroys a structure, object or property within an H historic preservation overlay district or a landmark site. (See subsection B7 of this section.)

7. Demolition, Partial: Partial demolition includes any act which destroys a portion of a structure consisting of not more than twenty five percent (25%) of the floor area of the structure, and where the portion of the structure to be demolished is not readily visible from the street. Partial demolition also includes the demolition or removal of additions or materials not of the historic period on any exterior elevation exceeding twenty five percent (25%) when the demolition is part of an act of restoring original historic elements of a structure and/or restoring a structure to its historical mass and size.

C. Establishment Of Overlay District:

1. Procedure For Establishment Of An H Historic Preservation Overlay District Or Landmark Site: An H historic preservation overlay district or landmark site shall be established pursuant to the procedures for amending the zoning map of this title in chapter 21A.50 of this title. An application for a map amendment to establish an H historic preservation overlay district or landmark site shall be prepared by the historic landmark commission and submitted to the planning commission. Any individual or organization can request that the historic landmark commission consider preparing an application of a landmark site or H historic preservation overlay district in the following manner:

a. The application shall contain information and recommendations concerning the areas, buildings and premises for areas included in the amendment application.:

(1) Information and recommendations concerning areas, buildings and premises for the areas included in the amendment application;

(2) Information evidencing that the areas included in the amendment application include all areas within any affected subdivision plat; and

(3) Information evidencing that at least fifty percent (50%) of the buildings located within the areas included in the amendment application have not been altered from their original construction.

b. The applicant shall be a property owner within the proposed areas included in the amendment application.

c. Prior to submitting the application, the applicant shall provide a notice of intent to submit and a copy of the proposed application to all property owners within the proposed areas included in the amendment application.

d. Within thirty (30) days of providing notice, the applicant shall obtain signatures in support of the petition from no less than seventy percent (70%) of all property owners within the proposed areas included in the amendment application.

e. Upon meeting these requirements, the applicant shall submit to the historic landmark commission the application, verifiable evidence of the required supporting signatures, and the fee required for a zoning map amendment under section 21A.64.010 (without regard to excess acreage fees).

f. If an applicant fails to obtain the required supporting signatures within thirty (30) days, or if the historic landmark commission rejects the application or fails to act on the application within ninety (90) days, then:

(1) The application shall be void and shall not be used; and

(2) No petition to create an H historic overlay district or landmark site may be initiated within the proposed areas included in the amendment application for a minimum of three (3) years following such rejection or the expiration of such thirty (30) day period or ninety (90) day period.

2. Criteria For Selection Of An H Historic Preservation Overlay District Or Landmark Site: The historic landmark commission shall evaluate each parcel of property within a proposed H historic preservation overlay district or the parcel of property associated with a landmark site. Individual parcels within a proposed district, the district as a whole, and landmark sites shall be evaluated according to the following:

a. Significance in local, regional, state or national history, architecture, engineering or culture, associated with at least one of the following:

(1) Events that have made significant contribution to the broad patterns of history, or

(2) Lives of persons significant in the history of the city, region, state, or nation, or

(3) The distinctive characteristics of a type, period or method of construction; or the work of a notable architect or master craftsman, or

(4) Information important in the understanding of the prehistory or history of Salt Lake City; and

b. Physical integrity in terms of location, design, setting, materials, workmanship, feeling and association as defined by the national park service for the National Register of Historic Places; and

c. The age of the site. Sites must be at least fifty (50) years old, or have achieved significance within the past fifty (50) years if the properties are of exceptional importance.

3. Boundaries Of A Proposed Historic Preservation Overlay District: When applying the evaluation criteria in subsection C2 of this section, the historic landmark commission shall recommend boundaries of a proposed H historic preservation overlay district to ensure that the boundaries:

a. Contain documented historic or architectural resources;

b. Coincide with documented historic boundaries such as early roadways, canals, subdivision plats or property lines;

c. Coincide with logical physical or manmade features and reflect recognized neighborhood boundaries; and

d. Contain nonhistoric resources or vacant land only where necessary to create appropriate boundaries to meet the criteria of subsection C2 of this section.

4. Boundaries Of A Proposed Landmark Site: When applying the evaluation criteria in subsection C2 of this section, the historic landmark commission shall draw the boundaries of a landmark site to ensure that historical associations, and/or those which best enhance the integrity of the site comprise the boundaries.

D. The Adjustment Of Boundaries Of An H Historic Preservation Overlay District And The Revocation Of The Designation Of Landmark Site:

1. Procedure: The procedure for the adjustment of boundaries of an H historic preservation overlay district and the revocation of the designation of a landmark site shall be the same as that outlined in subsection C1 of this section.

2. Criteria For Adjusting The Boundaries Of An H Historic Preservation Overlay District: Criteria for adjusting the boundaries of an H historic preservation overlay district are as follows:

- a. The properties have ceased to meet the criteria for inclusion within an H historic preservation overlay district because the qualities which caused them to be originally included have been lost or destroyed, or such qualities were lost subsequent to the historic landmark commission recommendation and adoption of the district;
- b. Additional information indicates that the properties do not comply with the criteria for selection of the H historic preservation overlay district as outlined in subsection C2 of this section; or
- c. Additional information indicates that the inclusion of additional properties would better convey the historical and architectural integrity of the H historic preservation overlay district, provided they meet the standards outlined in subsection C2 of this section.

3. Criteria For The Revocation Of The Designation Of A Landmark Site: Criteria for the revocation of the designation of a landmark site are as follows:

- a. The property has ceased to meet the criteria for designation as a landmark site because the qualities that caused it to be originally designated have been lost or destroyed or the structure has been demolished.
- b. Additional information indicates that the landmark site does not comply with the criteria for selection of a landmark site as outlined in subsection C2 of this section.
- c. Additional information indicates that the landmark site is not of exceptional importance to the city, state, region or nation.

E. Certificate Of Appropriateness Required: After the establishment of an H historic preservation overlay district, or the designation of a landmark site, no alteration in the exterior appearance of a structure, site, object or work of art affecting the landmark site or a property within the H historic preservation overlay district shall be made or permitted to be made unless or until the application for a certificate of appropriateness has been submitted to, and approved by, the historic landmark commission, or administratively by the planning director, as applicable, pursuant to subsection F of this section. Certificates of appropriateness shall be required for:

- 1. Any construction needing a building permit;
- 2. Removal and replacement or alteration of architectural detailing, such as porch columns, railing, window moldings, cornices and siding;
- 3. Relocation of a structure or object on the same site or to another site;
- 4. Construction of additions or decks;

5. Alteration or construction of accessory structures, such as garages, etc.;
6. Alterations to windows and doors, including replacement or changes in fenestration patterns;
7. Construction or alteration of porches;
8. Masonry work including, but not limited to, tuckpointing, sandblasting and chemical cleaning;
9. The construction or alterations of site features including, but not limited to, fencing, walls, paving and grading;
10. Installation or alteration of any exterior sign;
11. Any demolition;
12. New construction; and
13. Installation of an awning over a window or door.

F. Procedure For Issuance Of Certificate Of Appropriateness:

1. Administrative Decision: Certain types of construction or demolition may be approved administratively subject to the following procedures:

a. Types Of Construction Allowed Which May Be Approved By Administrative Decision:

- (1) Minor alteration of or addition to a landmark site or contributing site;
- (2) Substantial alteration of or addition to a noncontributing site;
- (3) Partial demolition of either a landmark site or a contributing structure;
- (4) Demolition of an accessory structure; and
- (5) Demolition of a noncontributing structure.

b. Submission Of Application: An application for a certificate of appropriateness shall be made on a form prepared by the planning director and shall be submitted to the planning division. The planning director shall make a determination of completeness pursuant to section 21A.10.010 of this title, and shall forward the application for review and decision.

c. Materials Submitted With Application: The application shall include photographs, construction drawings, and other documentation such as an architectural or massing model, window frame sections and samples deemed necessary to consider the application properly and completely.

d. Notice For Application For Demolition Of A Noncontributing Structure: An application for demolition of a noncontributing structure shall require notice for determination of noncontributing sites pursuant to subsection 21A.10.020F of this title.

e. Standards For Approval: The application shall be reviewed according to the standards set forth in subsections G and H of this section, whichever is applicable.

f. Review And Decision By The Planning Director: On the basis of written findings of fact, the planning director or the planning director's designee shall either approve, deny or conditionally approve the certificate of appropriateness based on the standards in subsections G and H of this section, whichever is applicable, within thirty (30) days following receipt of a completed application. The decision of the planning director shall become effective at the time the decision is made.

g. Referral Of Application By Planning Director To Historic Landmark Commission: The planning director may refer any application to the historic landmark commission due to the complexity of the application, the significance of change to the landmark site or contributing structure in the H historic preservation overlay district, or the need for consultation for expertise regarding architectural, construction or preservation issues.

h. Appeal Of Administrative Decision To Historic Landmark Commission: The applicant, if aggrieved by the administrative decision, may appeal the decision to the historic landmark commission within ten (10) calendar days following the date on which a record of decision is issued. Once an appeal of an administrative decision has been filed, the procedure shall be as outlined in subsection F2 of this section.

2. Historic Landmark Commission: Certain types of construction, demolition and relocation shall only be allowed to be approved by the historic landmark commission subject to the following procedures:

a. Types Of Construction To Be Reviewed By The Historic Landmark Commission:

- (1) Substantial alteration or addition to a landmark site or contributing site;
- (2) New construction of principal building in H historic preservation overlay district;
- (3) Relocation of landmark site or contributing site;
- (4) Demolition of landmark site or contributing site;
- (5) Applications for administrative approval referred by the planning director; and

(6) Appeal of administrative decisions by the applicant.

b. Submission Of Application: The procedure for an application for a certificate of appropriateness shall be the same as specified in subsection F1b of this section.

c. Materials Submitted With Application: The requirements for the materials to be submitted upon application for a certificate of appropriateness shall be the same as specified in subsection F1c of this section. Applications for a certificate of appropriateness for demolition shall also submit a reuse plan for the property.

d. Notice: Applications for a certificate of appropriateness shall require notice pursuant to subsection 21A.10.020E of this title.

e. Public Hearing: Applications for a certificate of appropriateness shall require a public hearing pursuant to section 21A.10.030 of this title.

f. Standards For Approval: The application shall be reviewed according to the standards set forth in subsections G through L of this section, whichever are applicable.

g. Review And Decision By The Historic Landmark Commission: The historic landmark commission shall make a decision at a regularly scheduled meeting, within sixty (60) days following receipt of a completed application, except that a review and decision on an application for a certificate of appropriateness for demolition of a landmark site or contributing structure declaring an economic hardship shall be made within one hundred twenty (120) days following receipt of a completed application.

(1) After reviewing all materials submitted for the case, the recommendation of the planning division and conducting a field inspection, if necessary, the historic landmark commission shall make written findings of fact based on the standards of approval as outlined in this subsections F through L of this section, whichever are applicable.

(2) On the basis of its written findings of fact the historic landmark commission shall either approve, deny or conditionally approve the certificate of appropriateness. A decision on an application for a certificate of appropriateness for demolition of a contributing structure may be deferred for up to one year pursuant to subsections L and M of this section.

(3) The decision of the historic landmark commission shall become effective at the time the decision is made. Demolition permits for landmark sites or contributing structures shall not be issued until the appeal period has expired.

(4) Written notice of the decision of the historic landmark commission on the application, including a copy of the findings of fact, shall be sent by first class mail to the applicant within ten (10) working days following the historic landmark commission's decision.

h. Appeal Of Historic Landmark Commission Decision To Land Use Appeals Board: The applicant, any owner of abutting property or of property located within the same H historic preservation overlay district, any recognized or registered organization pursuant to title 2, chapter 2.62 of this code, the Utah State Historical Society or the Utah Heritage Foundation, aggrieved by the historic landmark commission's decision, may object to the decision by filing a written appeal with the land use appeals board within ten (10) calendar days following the date on which a record of decision is issued. The filing of the appeal shall stay the decision of the historic landmark commission pending the outcome of the appeal, except that the filing of the appeal shall not stay the decision of the historic landmark commission if such decision defers a demolition request for up to one year pursuant to the provisions of subsections L and M of this section.

i. Review By City Attorney: Following the filing of an appeal to the land use appeals board of a decision of the historic landmark commission to deny or defer a certificate of appropriateness for demolition, the planning director shall secure an opinion of the city attorney evaluating whether the denial or deferral of a decision of the demolition would result in an unconstitutional taking of property without just compensation under the Utah and United States constitutions or otherwise violate any applicable constitutional provision, law, ordinance or regulation.

j. Appeal Of Land Use Appeals Board Decision To District Court: Any party aggrieved by the decision of the land use appeals board may appeal that decision to the district court within thirty (30) days following the decision of the land use appeals board. The filing of an appeal of the land use appeals board decision shall stay the decision of the land use appeals board pending the outcome of the appeal, except that the filing of the appeal shall not stay the decision of the land use appeals board if such decision defers a demolition request for up to one year pursuant to the provisions of subsections L and M of this section.

G. Standards For Certificate Of Appropriateness For Alteration Of A Landmark Site Or Contributing Structure: In considering an application for a certificate of appropriateness for alteration of a landmark site or contributing structure, the historic landmark commission, or the planning director, for administrative decisions, shall find that the project substantially complies with all of the following general standards that pertain to the application and that the decision is in the best interest of the city:

1. A property shall be used for its historic purpose or be used for a purpose that requires minimal change to the defining characteristics of the building and its site and environment;
2. The historic character of a property shall be retained and preserved. The removal of historic materials or alteration of features and spaces that characterize a property shall be avoided;

3. All sites, structures and objects shall be recognized as products of their own time. Alterations that have no historical basis and which seek to create a false sense of history or architecture are not allowed;
4. Alterations or additions that have acquired historic significance in their own right shall be retained and preserved;
5. Distinctive features, finishes and construction techniques or examples of craftsmanship that characterize a historic property shall be preserved;
6. Deteriorated architectural features shall be repaired rather than replaced wherever feasible. In the event replacement is necessary, the new material should match the material being replaced in composition, design, texture and other visual qualities. Repair or replacement of missing architectural features should be based on accurate duplications of features, substantiated by historic, physical or pictorial evidence rather than on conjectural designs or the availability of different architectural elements from other structures or objects;
7. Chemical or physical treatments, such as sandblasting, that cause damage to historic materials shall not be used. The surface cleaning of structures, if appropriate, shall be undertaken using the gentlest means possible;
8. Contemporary design for alterations and additions to existing properties shall not be discouraged when such alterations and additions do not destroy significant cultural, historical, architectural or archaeological material, and such design is compatible with the size, scale, color, material and character of the property, neighborhood or environment;
9. Additions or alterations to structures and objects shall be done in such a manner that if such additions or alterations were to be removed in the future, the essential form and integrity of the structure would be unimpaired. The new work shall be differentiated from the old and shall be compatible in massing, size, scale and architectural features to protect the historic integrity of the property and its environment;
10. Certain building materials are prohibited including the following:
 - a. Vinyl or aluminum cladding when applied directly to an original or historic material, and
 - b. Any other imitation siding material designed to look like wood siding but fabricated from an imitation material or materials;
11. Any new sign and any change in the appearance of any existing sign located on a landmark site or within the H historic preservation overlay district, which is visible from any public way or open space shall be consistent with the historic character of the landmark site or H historic preservation overlay district and shall comply with the standards outlined in chapter 21A.46 of this title;

12. Additional design standards adopted by the historic landmark commission and city council.

H. Standards For Certificate Of Appropriateness Involving New Construction Or Alteration Of A Noncontributing Structure: In considering an application for a certificate of appropriateness involving new construction, or alterations of noncontributing structures, the historic landmark commission, or planning director when the application involves the alteration of a noncontributing structure, shall determine whether the project substantially complies with all of the following standards that pertain to the application, is visually compatible with surrounding structures and streetscape as illustrated in any design standards adopted by the historic landmark commission and city council and is in the best interest of the city:

1. Scale And Form:

a. Height And Width: The proposed height and width shall be visually compatible with surrounding structures and streetscape;

b. Proportion Of Principal Facades: The relationship of the width to the height of the principal elevations shall be in scale with surrounding structures and streetscape;

c. Roof Shape: The roof shape of a structure shall be visually compatible with the surrounding structures and streetscape; and

d. Scale Of A Structure: The size and mass of the structures shall be visually compatible with the size and mass of surrounding structure and streetscape.

2. Composition Of Principal Facades:

a. Proportion Of Openings: The relationship of the width to the height of windows and doors of the structure shall be visually compatible with surrounding structures and streetscape;

b. Rhythm Of Solids To Voids In Facades: The relationship of solids to voids in the facade of the structure shall be visually compatible with surrounding structures and streetscape;

c. Rhythm Of Entrance Porch And Other Projections: The relationship of entrances and other projections to sidewalks shall be visually compatible with surrounding structures and streetscape; and

d. Relationship Of Materials: The relationship of the color and texture of materials (other than paint color) of the facade shall be visually compatible with the predominant materials used in surrounding structures and streetscape.

3. Relationship To Street:

a. Walls Of Continuity: Facades and site structures, such as walls, fences and landscape masses, shall, when it is characteristic of the area, form continuity along a street to ensure visual compatibility with the structures, public ways and places to which such elements are visually related;

b. Rhythm Of Spacing And Structures On Streets: The relationship of a structure or object to the open space between it and adjoining structures or objects shall be visually compatible with the structures, objects, public ways and places to which it is visually related;

c. Directional Expression Of Principal Elevation: A structure shall be visually compatible with the structures, public ways and places to which it is visually related in its orientation toward the street; and

d. Streetscape; Pedestrian Improvements: Streetscape and pedestrian improvements and any change in its appearance shall be compatible to the historic character of the landmark site or H historic preservation overlay district.

4. Subdivision Of Lots: The planning director shall review subdivision plats proposed for property within an H historic preservation overlay district or of a landmark site and may require changes to ensure the proposed subdivision will be compatible with the historic character of the district and/or site(s).

I. Standards For Certificate Of Appropriateness For Relocation Of Landmark Site Or Contributing Structure: In considering an application for a certificate of appropriateness for relocation of a landmark site or a contributing structure, the historic landmark commission shall find that the project substantially complies with the following standards:

1. The proposed relocation will abate demolition of the structure;

2. The proposed relocation will not diminish the overall physical integrity of the district or diminish the historical associations used to define the boundaries of the district;

3. The proposed relocation will not diminish the historical or architectural significance of the structure;

4. The proposed relocation will not have a detrimental effect on the structural soundness of the building or structure;

5. A professional building mover will move the building and protect it while being stored; and

6. A financial guarantee to ensure the rehabilitation of the structure once the relocation has occurred is provided to the city. The financial guarantee shall be in a form approved by the city attorney, in an amount determined by the planning director sufficient to cover the estimated cost to rehabilitate the structure as approved by the historic landmark commission and restore the grade and landscape the property from which the structure was removed in the event the land is to be left vacant once the relocation of the structure occurs.

J. Standards For Certificate Of Appropriateness For Demolition Of Landmark Site: In considering an application for a certificate of appropriateness for demolition of a landmark site, the historic landmark commission shall only approve the application upon finding that the project fully complies with one of the following standards:

1. The demolition is required to alleviate a threat to public health and safety pursuant to subsection Q of this section; or
2. The demolition is required to rectify a condition of economic hardship, as defined and determined pursuant to the provisions of subsection K. of this section.

K. Definition And Determination Of Economic Hardship: The determination of economic hardship shall require the applicant to provide evidence sufficient to demonstrate that the application of the standards and regulations of this section deprives the applicant of all reasonable economic use or return on the subject property.

1. Application For Determination Of Economic Hardship: An application for a determination of economic hardship shall be made on a form prepared by the planning director and shall be submitted to the planning division. The application must include photographs, information pertaining to the historic significance of the landmark site and all information necessary to make findings on the standards for determination of economic hardship.

2. Standards For Determination Of Economic Hardship: The historic landmark commission shall apply the following standards and make findings concerning economic hardship:

- a. The applicant's knowledge of the landmark designation at the time of acquisition, or whether the property was designated subsequent to acquisition;
- b. The current level of economic return on the property as considered in relation to the following:

(1) The amount paid for the property, the date of purchase, and party from whom purchased, including a description of the relationship, if any, between the owner of record or applicant, and the person from whom the property was purchased,

(2) The annual gross and net income, if any, from the property for the previous three (3) years; itemized operating and maintenance expenses for the previous three (3) years; and depreciation deduction and annual cash flow before and after debt service, if any, for the previous three (3) years,

(3) Remaining balance on any mortgage or other financing secured by the property and annual debt service, if any, during the previous three (3) years,

(4) Real estate taxes for the previous four (4) years and assessed value of the property according to the two (2) most recent assessed valuations by the Salt Lake County assessor,

(5) All appraisals obtained within the previous two (2) years by the owner or applicant in connection with the purchase, financing or ownership of the property,

(6) The fair market value of the property immediately prior to its designation as a landmark site and the fair market value of the property as a landmark site at the time the application is filed,

(7) Form of ownership or operation of the property, i.e., sole proprietorship, for profit corporation or not for profit corporation, limited partnership, joint venture, etc., and

(8) Any state or federal income tax returns on or relating to the property for the previous two (2) years;

c. The marketability of the property for sale or lease, considered in relation to any listing of the property for sale or lease, and price asked and offers received, if any, within the previous two (2) years. This determination can include testimony and relevant documents regarding:

(1) Any real estate broker or firm engaged to sell or lease the property,

(2) Reasonableness of the price or rent sought by the applicant, and

(3) Any advertisements placed for the sale or rent of the property;

d. The infeasibility of alternative uses that can earn a reasonable economic return for the property as considered in relation to the following:

(1) A report from a licensed engineer or architect with experience in rehabilitation as to the structural soundness of any structures on the property and their suitability for rehabilitation,

(2) Estimate of the cost of the proposed construction, alteration, demolition or removal, and an estimate of any additional cost that would be incurred to comply with the decision of the historic landmark commission concerning the appropriateness of proposed alterations,

(3) Estimated market value of the property in the current condition after completion of the demolition and proposed new construction; and after renovation of the existing property for continued use, and

(4) The testimony of an architect, developer, real estate consultant, appraiser, or other professional experienced in rehabilitation as to the economic feasibility of rehabilitation or reuse of the existing structure on the property;

e. Economic incentives and/or funding available to the applicant through federal, state, city, or private programs.

3. Procedure For Determination Of Economic Hardship: The historic landmark commission shall establish a three (3) person economic review panel. This panel shall be comprised of three (3) real estate and redevelopment experts knowledgeable in real estate economics in general, and more specifically, in the economics of renovation, redevelopment and other aspects of rehabilitation. The panel shall consist of one person selected by the historic landmark commission, one person selected by the applicant, and one person selected by the first two (2) appointees. If the first two (2) appointees cannot agree on a third person within thirty (30) days of the date of the initial public hearing, the third appointee shall be selected by the mayor within five (5) days after the expiration of the thirty (30) day period.

a. Review Of Evidence: All of the evidence and documentation presented to the historic landmark commission shall be made available to and reviewed by the economic review panel. The economic review panel shall convene a meeting complying with the open meetings act to review the evidence of economic hardship in relation to the standards set forth in subsection K2 of this section. The economic review panel may, at its discretion, convene a public hearing to receive testimony by any interested party; provided, that notice for such public hearing shall be in accordance with chapter 21A.10, "General Application And Public Hearing Procedures", subsection 21A.10.020E and section 21A.10.030 of this title.

b. Report Of Economic Review Panel: Within forty five (45) days after the economic review panel is established, the panel shall complete an evaluation of economic hardship, applying the standards set forth in subsection K2 of this section and shall forward a written report with its findings of fact and conclusions to the historic landmark commission.

c. Historic Landmark Commission Determination Of Economic Hardship: At the next regular historic landmark commission meeting following receipt of the report of the

economic review panel, the historic landmark commission shall reconvene its public hearing to take final action on the application.

(1) Finding Of Economic Hardship: If after reviewing all of the evidence, the historic landmark commission finds that the application of the standards set forth in subsection K2 of this section results in economic hardship, then the historic landmark commission shall issue a certificate of appropriateness for demolition.

(2) Denial Of Economic Hardship: If the historic landmark commission finds that the application of the standards set forth in subsection K2 of this section does not result in economic hardship then the certificate of appropriateness for demolition shall be denied.

(3) Consistency With The Economic Review Panel Report: The historic landmark commission decision shall be consistent with the conclusions reached by the economic review panel unless, based on all of the evidence and documentation presented to the historic landmark commission, the historic landmark commission finds by a vote of three-fourths ($\frac{3}{4}$) majority of a quorum present that the economic review panel acted in an arbitrary manner, or that its report was based on an erroneous finding of a material fact.

L. Standards For Certificate Of Appropriateness For Demolition Of A Contributing Structure In An H Historic Preservation Overlay District: In considering an application for a certificate of appropriateness for demolition of a contributing structure, the historic landmark commission shall determine whether the project substantially complies with the following standards:

1. Standards For Approval Of A Certificate Of Appropriateness For Demolition:

a. The physical integrity of the site as defined in subsection C2b of this section is no longer evident;

b. The streetscape within the context of the H historic preservation overlay district would not be negatively affected;

c. The demolition would not adversely affect the H historic preservation overlay district due to the surrounding noncontributing structures;

d. The base zoning of the site is incompatible with reuse of the structure;

e. The reuse plan is consistent with the standards outlined in subsection H of this section;

f. The site has not suffered from wilful neglect, as evidenced by the following:

(1) Wilful or negligent acts by the owner that deteriorates the structure,

- (2) Failure to perform normal maintenance and repairs,
- (3) Failure to diligently solicit and retain tenants, and
- (4) Failure to secure and board the structure if vacant; and

g. The denial of a certificate of appropriateness for demolition would cause an economic hardship as defined and determined pursuant to the provisions of subsection K of this section.

2. Historic Landmark Commission Determination Of Compliance With Standards Of Approval: The historic landmark commission shall make a decision based upon compliance with the requisite number of standards in subsection L1 of this section as set forth below.

a. Approval Of Certificate Of Appropriateness For Demolition: Upon making findings that at least six (6) of the standards are met, the historic landmark commission shall approve the certificate of appropriateness for demolition.

b. Denial Of Certificate Of Appropriateness For Demolition: Upon making findings that two (2) or less of the standards are met, the historic landmark commission shall deny the certificate of appropriateness for demolition.

c. Deferral Of Decision For Up To One Year: Upon making findings that three (3) to five (5) of the standards are met, the historic landmark commission shall defer a decision for up to one year during which the applicant must conduct a bona fide effort to preserve the site pursuant to subsection M of this section.

M. Bona Fide Preservation Effort: Upon the decision of the historic landmark commission to defer the decision of a certificate of appropriateness for demolition for up to one year, the applicant must undertake bona fide efforts to preserve the structure. The one year period shall begin only when the bona fide effort has commenced. A bona fide effort shall consist of all of the following actions:

- 1. Marketing the property for sale or lease;
- 2. Filing an application for alternative funding sources for preservation, such as federal or state preservation tax credits, Utah heritage revolving fund loans, redevelopment agency loans, etc.;
- 3. Filing an application for alternative uses if available or feasible, such as conditional uses, special exceptions, etc.; and

4. Obtaining written statements from licensed building contractors or architects detailing the actual costs to rehabilitate the property.

N. Final Decision For Certificate Of Appropriateness For Demolition Following One Year Deferral: Upon the completion of the one year period and if the applicant provides evidence of a bona fide preservation effort, the historic landmark commission shall make a final decision for the certificate of appropriateness for demolition pursuant to subsection F2 of this section. The historic landmark commission shall approve the certificate of appropriateness for demolition and approve, approve with modifications or deny the certificate of appropriateness for the reuse plan for new construction pursuant to subsection F2, H or P of this section.

O. Recordation Requirement For Approved Certificate Of Appropriateness For Demolition: Upon approval of a certificate of appropriateness for demolition of a landmark site or a contributing structure, the historic landmark commission shall require the applicant to provide archival quality photographs, plans or elevation drawings, as available, necessary to record the structure(s) being demolished.

P. Review Of Postdemolition Plan For New Construction Or Landscape Plan And Bond Requirements For Approved Certificate Of Appropriateness For Demolition: Prior to approval of any certificate of appropriateness for demolition the historic landmark commission shall review the postdemolition plans to assure that the plans comply with the standards of subsection H of this section. If the postdemolition plan is to landscape the site, a bond shall be required to ensure the completion of the landscape plan approved by the historic landmark commission. The design standards and guidelines for the landscape plan are provided in section 21A.48.050 of this title.

1. The bond shall be issued in a form approved by the city attorney. The bond shall be in an amount determined by the zoning administrator and shall be sufficient to cover the estimated cost, to: a) restore the grade as required by title 18 of this code; b) install an automatic sprinkling system; and c) revegetate and landscape as per the approved plan.

2. The bond shall require installation of landscaping and sprinklers within six (6) months, unless the owner has obtained a building permit and commenced construction of a building or structure on the site.

Q. Exceptions Of Certificate Of Appropriateness For Demolition Of Hazardous Structures: A hazardous structure shall be exempt from the provisions governing

demolition if the building official determines, in writing, that the building currently is an imminent hazard to public safety. Hazardous structures demolished under this section shall comply with subsection P of this section. Prior to the issuance of a demolition permit, the building official shall notify the planning director of the decision. (Ord. 69-09 §§ 6, 7, 2009; Ord. 77-03 §§ 6, 7, 2003; Ord. 35-99 §§ 42 _ 44, 1999; Ord. 83-96 §§ 4, 5, 1996; Ord. 70-96 § 1, 1996; Ord. 88-95 § 1 (Exh. A), 1995; Ord. 26-95 § 2(17-1), 1995)

Document comparison by Workshare Professional on Wednesday, October 06, 2010 1:44:24 PM

Input:	
Document 1 ID	interwovenSite://slcdm1/WorksiteSLC/698751/1
Description	#698751v1<WorksiteSLC> - Original Text for Overlay and Historic District Ordinances
Document 2 ID	interwovenSite://SLCDM1/WorksiteSLC/697433/1
Description	#697433v1<WorksiteSLC> - Amendment to Yalecrest Compatible Infill Overlay District
Rendering set	standard

Legend:	
<u>Insertion</u>	
Deletion	
Moved from	
<u>Moved to</u>	
Style change	
Format change	
Added/Deleted	
Inserted cell	
Deleted cell	
Moved cell	
Split/Merged cell	
Padding cell	

Statistics:	
	Count
Insertions	36
Deletions	4
Moved from	2
Moved to	2
Style change	0
Format changed	0
Total changes	44

Stricter zoning rules could address neighborhood concerns.

1. Agree
2. Disagree

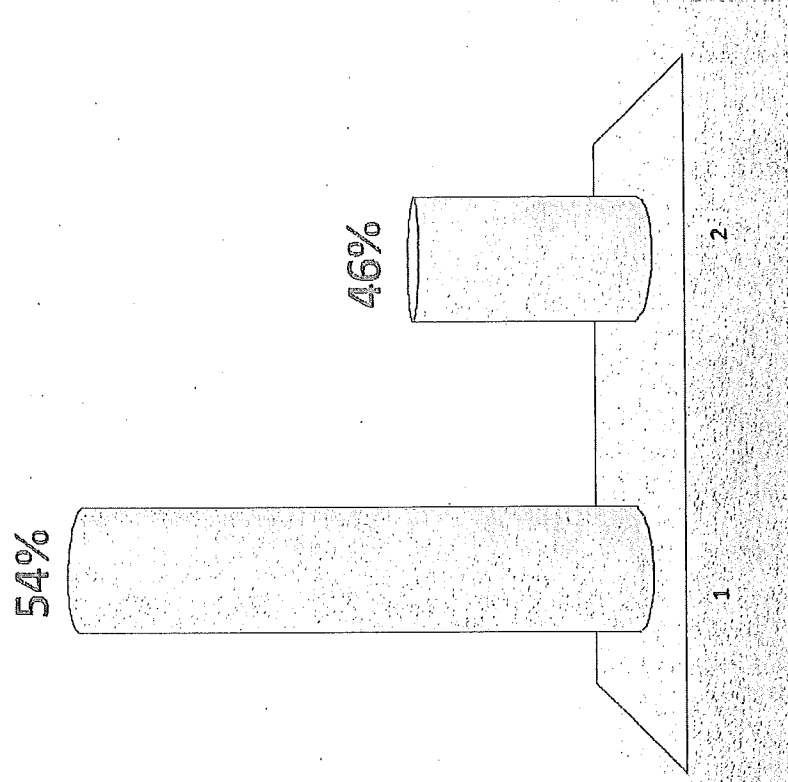

The following pages contain unofficial data results received during the four community meetings regarding the proposed Local Yalecrest Historic District. Questions given were not scientific, professionally formulated, or intended to constitute a vote. The results in the document are not indicative of a vote or a final decision and only represent a small portion of the entire area; the results are to gain general insight from the participating residents.

I would like to retain the character of the neighborhood but I do not know if a local historic district is the right way to do this.

1. Agree
2. Disagree

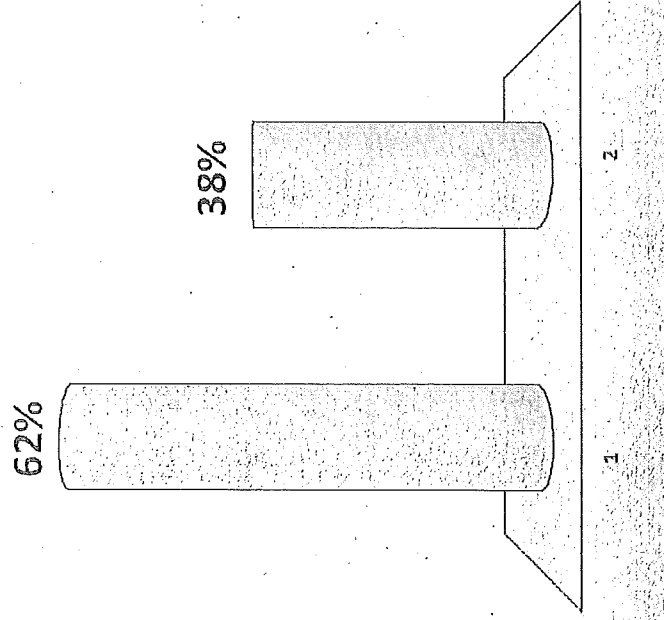

The following pages contain unofficial data results received during the four community meetings regarding the proposed Local Yalecrest Historic District. Questions given were not scientific, professionally formulated, or intended to constitute a vote. The results in the document are not indicative of a vote or a final decision and only represent a small portion of the entire area; the results are to gain general insight from the participating residents.

I believe we need the local historic district before the loss of more houses.

1. Agree
2. Disagree

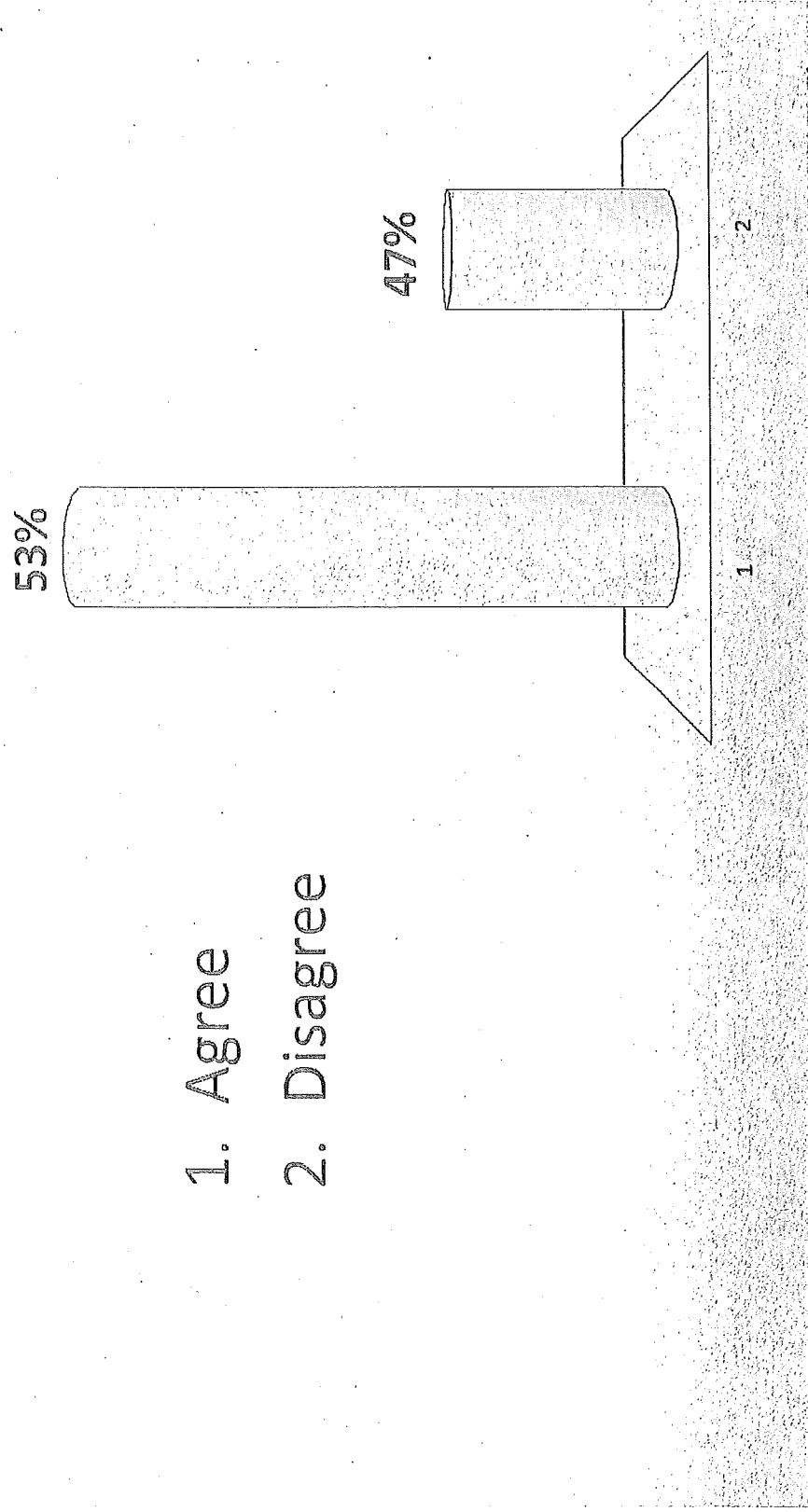

The following pages contain unofficial data results received during the four community meetings regarding the proposed Local Yalecrest Historic District. Questions given were not scientific, professionally formulated, or intended to constitute a vote. The results in the document are not indicative of a vote or a final decision and only represent a small portion of the entire area; the results are to gain general insight from the participating residents.

The historic district would be too restrictive – I believe we need other options to help.

1. Agree
2. Disagree

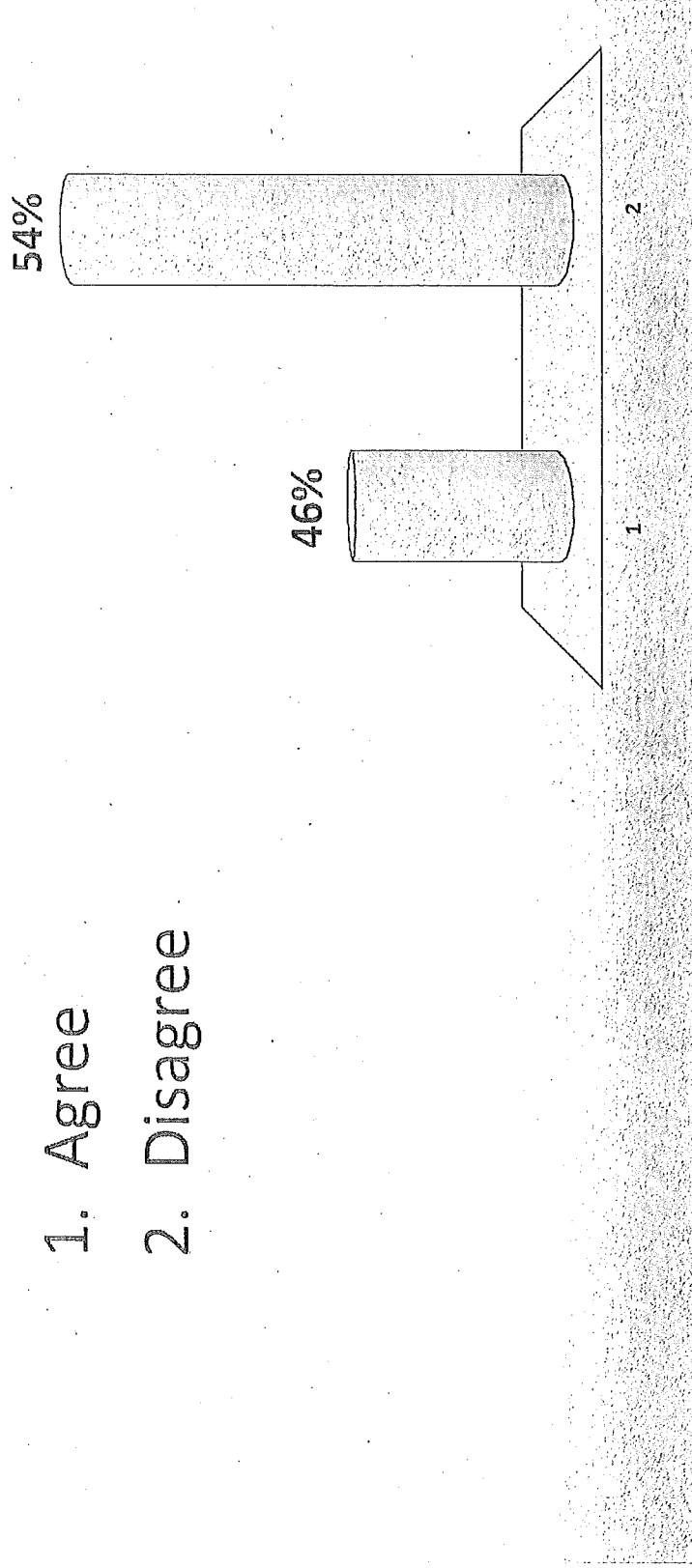

The following pages contain unofficial data results received during the four community meetings regarding the proposed Local Yalecrest Historic District. Questions given were not scientific, professionally formulated, or intended to constitute a vote. The results in the document are not indicative of a vote or a final decision and only represent a small portion of the entire area; the results are to gain general insight from the participating residents.

The Spring weather we're having is...?

1. Just perfect, wouldn't have it any other way!
2. Enough rain already!
3. That groundhog is full of crap!
4. I don't like the sun it give me freckles, more rain please!

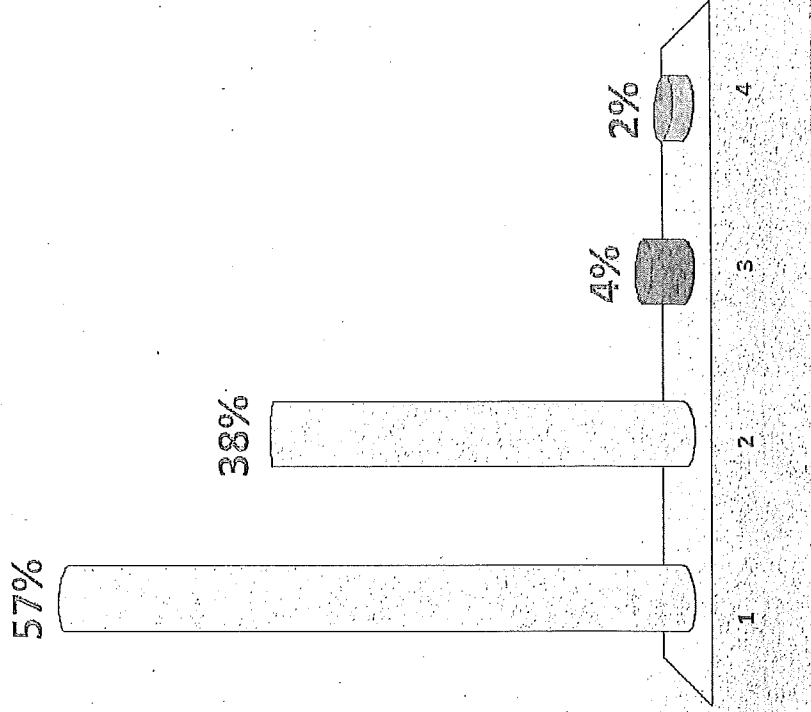

The following pages contain unofficial data results received during the four community meetings regarding the proposed Local Yalecrest Historic District. Questions given were not scientific, professionally formulated, or intended to constitute a vote. The results in the document are not indicative of a vote or a final decision and only represent a small portion of the entire area; the results are to gain general insight from the participating residents.

It is quicker by train than to Boston.

1. True
2. False

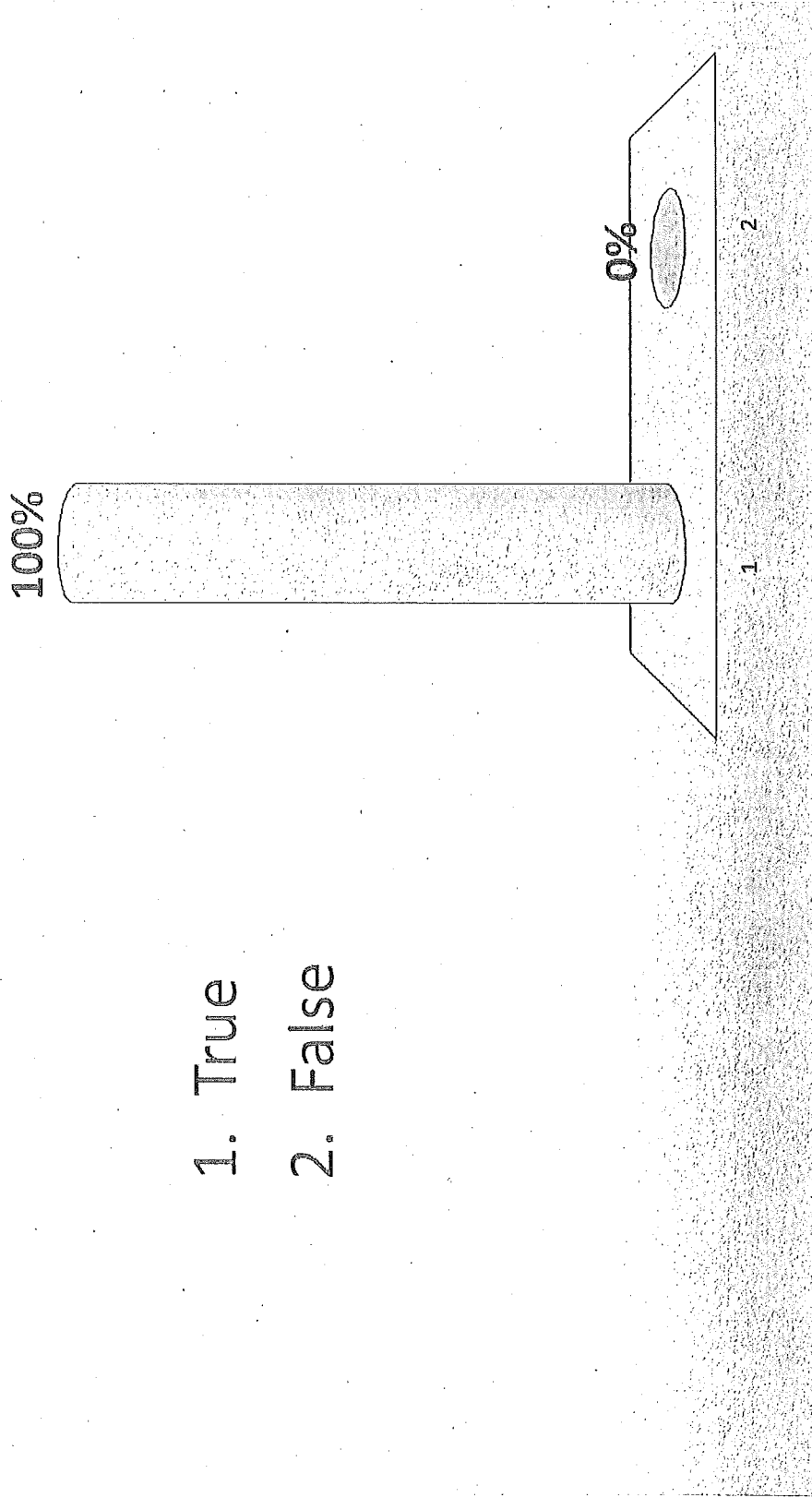

The following pages contain unofficial data results received during the four community meetings regarding the proposed Local Yalecrest Historic District. Questions given were not scientific, professionally formulated, or intended to constitute a vote. The results in the document are not indicative of a vote or a final decision and only represent a small portion of the entire area; the results are to gain general insight from the participating residents.

I would rather have one of the following, than another historic preservation discussion...

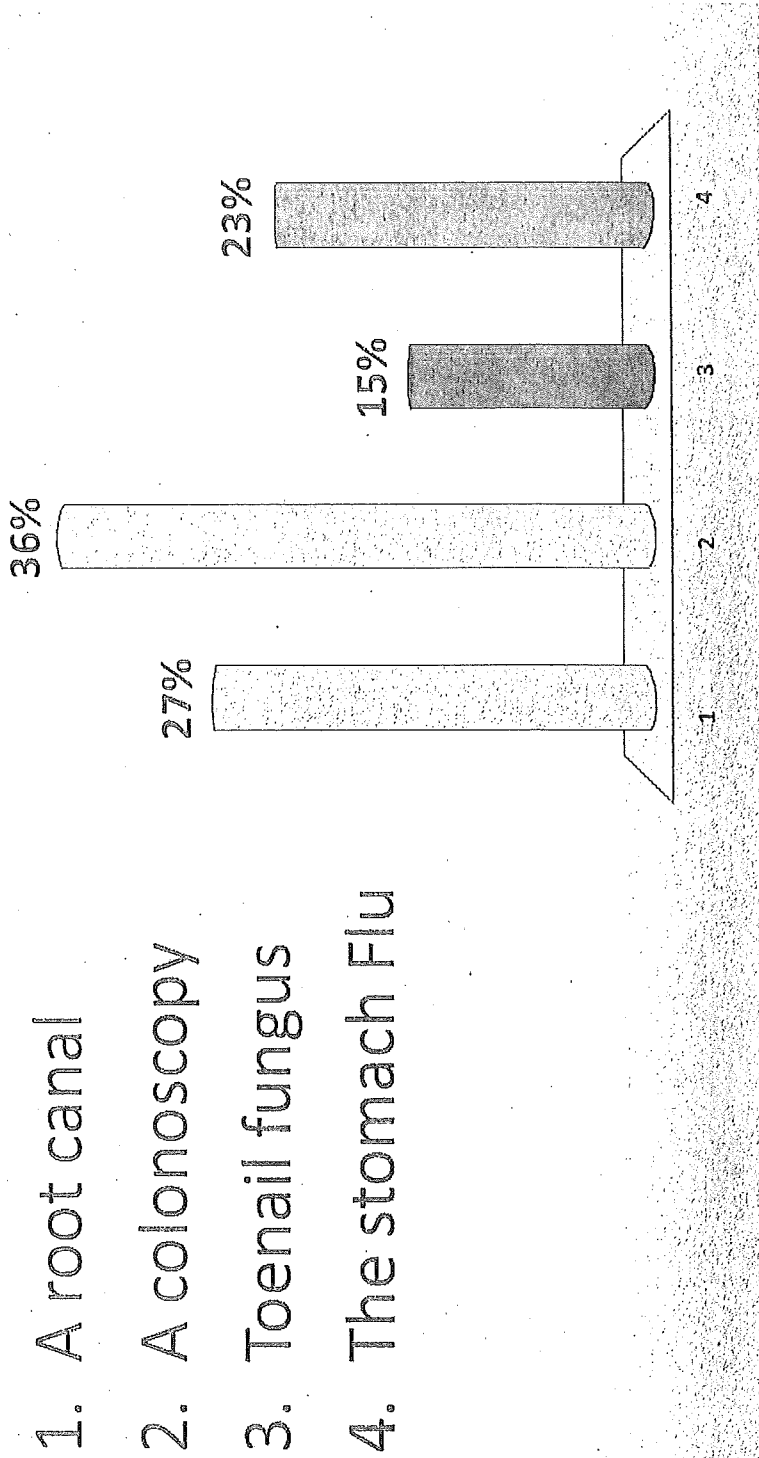

The following pages contain unofficial data results received during the four community meetings regarding the proposed Local Yalecrest Historic District. Questions given were not scientific, professionally formulated, or intended to constitute a vote. The results in the document are not indicative of a vote or a final decision and only represent a small portion of the entire area; the results are to gain general insight from the participating residents.

Who is the Mayor of Salt Lake City?

1. Chris Buttars
2. John English
3. Ralph Becker
4. Kevin Garn

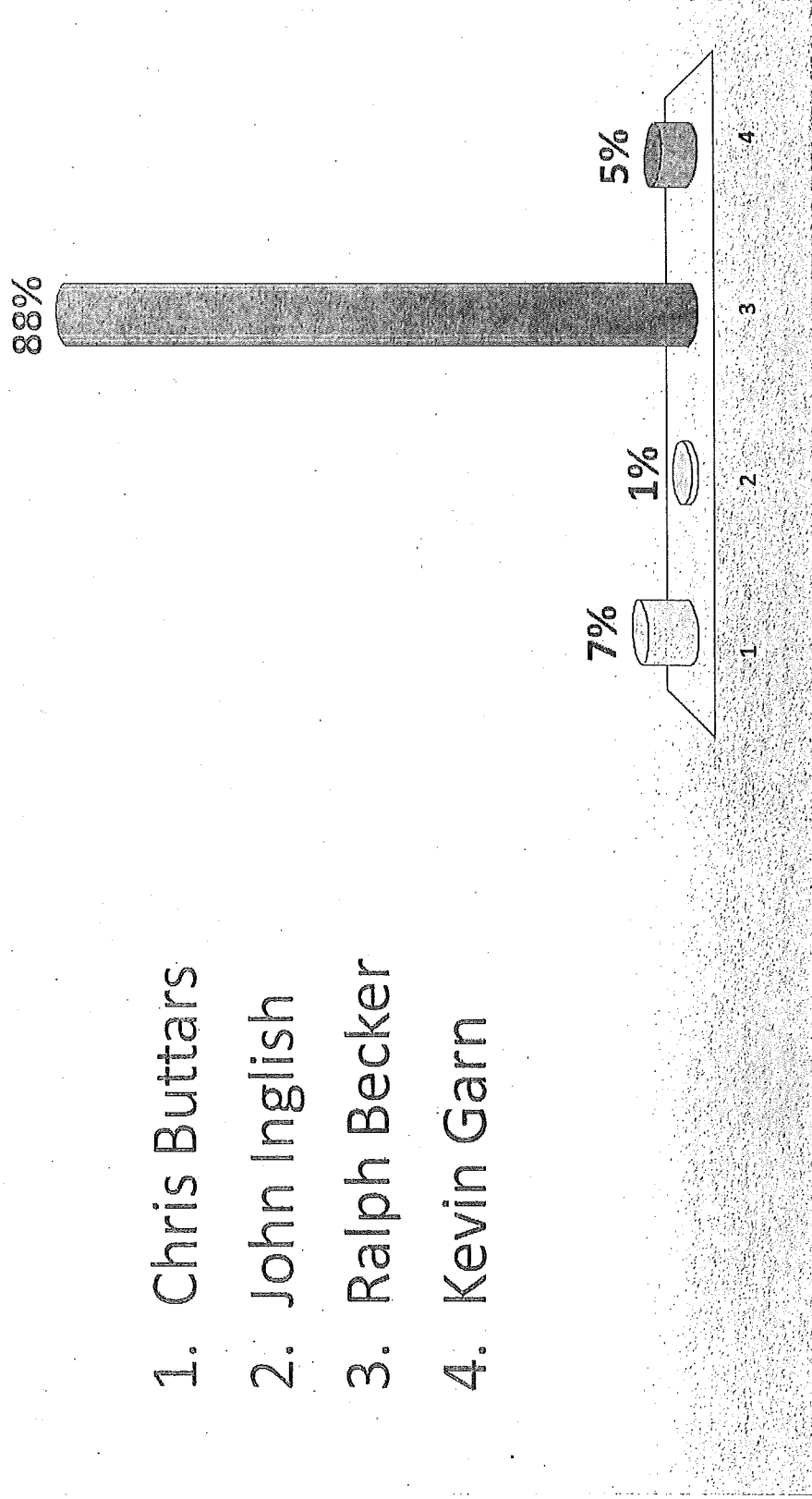

The following pages contain unofficial data results received during the four community meetings regarding the proposed Local Yalecrest Historic District. Questions given were not scientific, professionally formulated, or intended to constitute a vote. The results in the document are not indicative of a vote or a final decision and only represent a small portion of the entire area; the results are to gain general insight from the participating residents.

Living in a historic district limits the choice of colors you can paint your house.

- 1. True
- 2. False

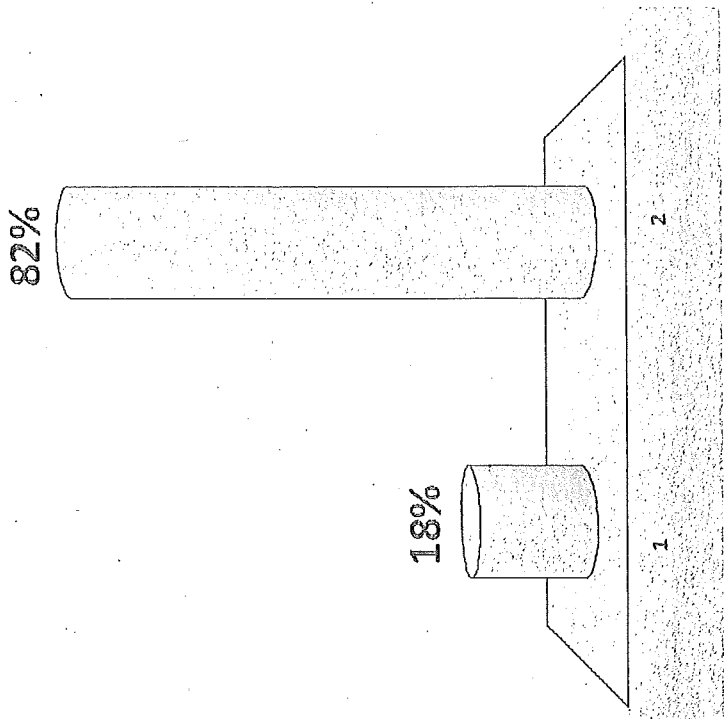

The following pages contain unofficial data results received during the four community meetings regarding the proposed Local Yalecrest Historic District. Questions given were not scientific, professionally formulated, or intended to constitute a vote. The results in the document are not indicative of a vote or a final decision and only represent a small portion of the entire area; the results are to gain general insight from the participating residents.

Additions are not allowed under local historic district regulations.

1. True
2. False

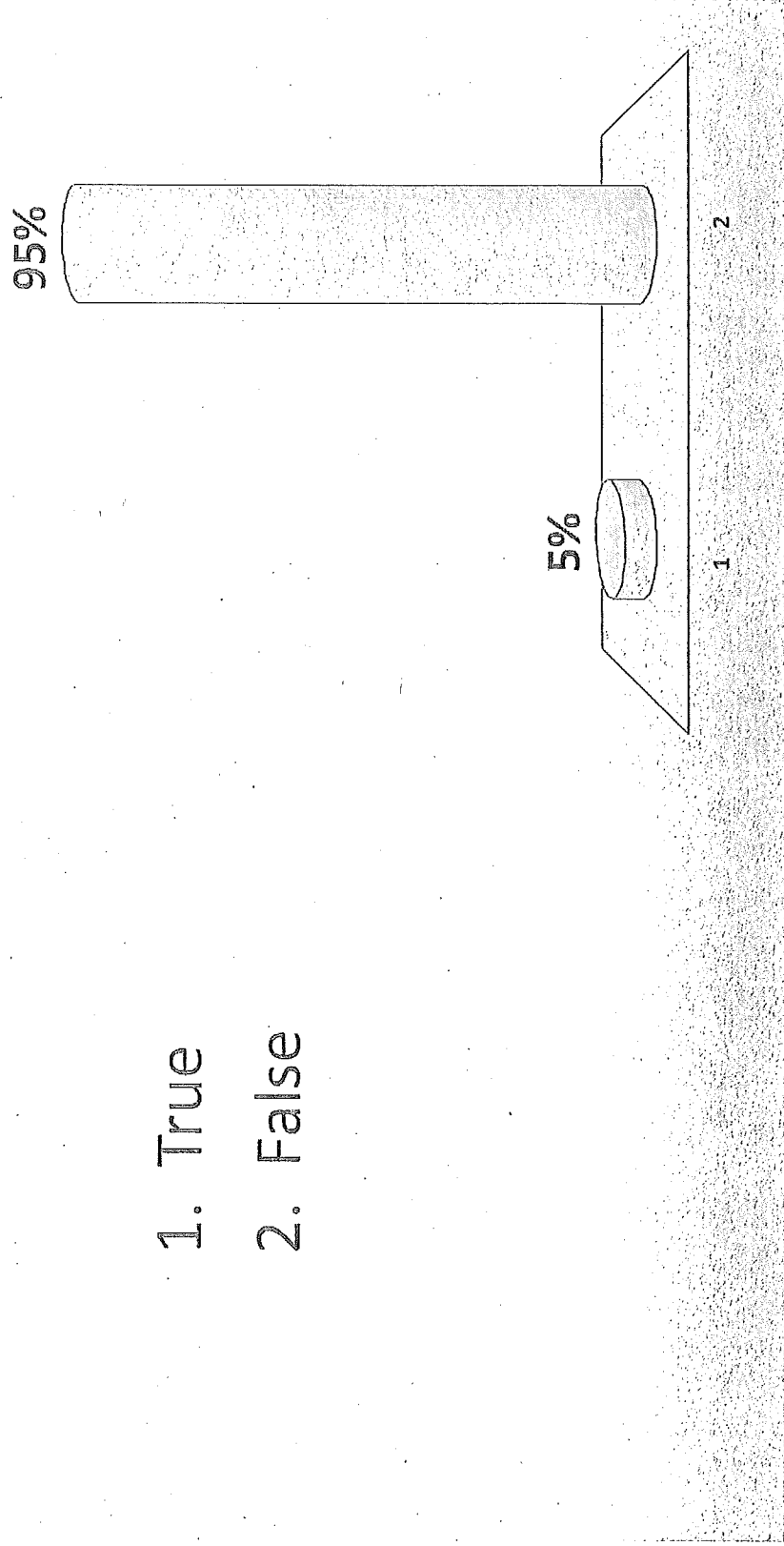

The following pages contain unofficial data results received during the four community meetings regarding the proposed Local Yalecrest Historic District. Questions given were not scientific, professionally formulated, or intended to constitute a vote. The results in the document are not indicative of a vote or a final decision and only represent a small portion of the entire area; the results are to gain general insight from the participating residents.

Demolitions are not allowed in a historic district.

- 1. True
- 2. False

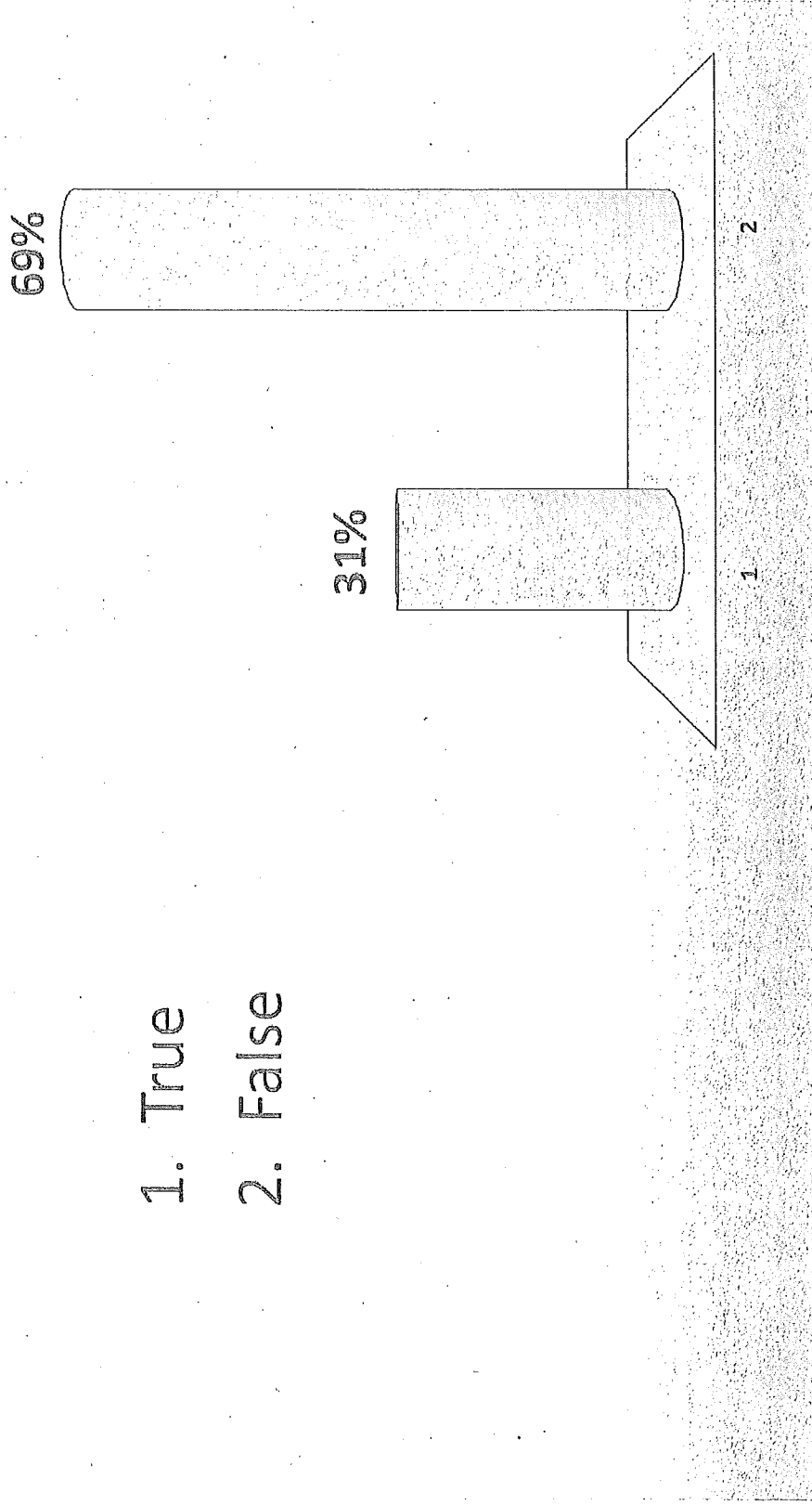

The following pages contain unofficial data results received during the four community meetings regarding the proposed Local Yalecrest Historic District. Questions given were not scientific, professionally formulated, or intended to constitute a vote. The results in the document are not indicative of a vote or a final decision and only represent a small portion of the entire area; the results are to gain general insight from the participating residents.

In most cases in a historic district, you would not be allowed to change in any significant way the front facade of your home to include dormers, windows and roof lines.

1. True
2. False

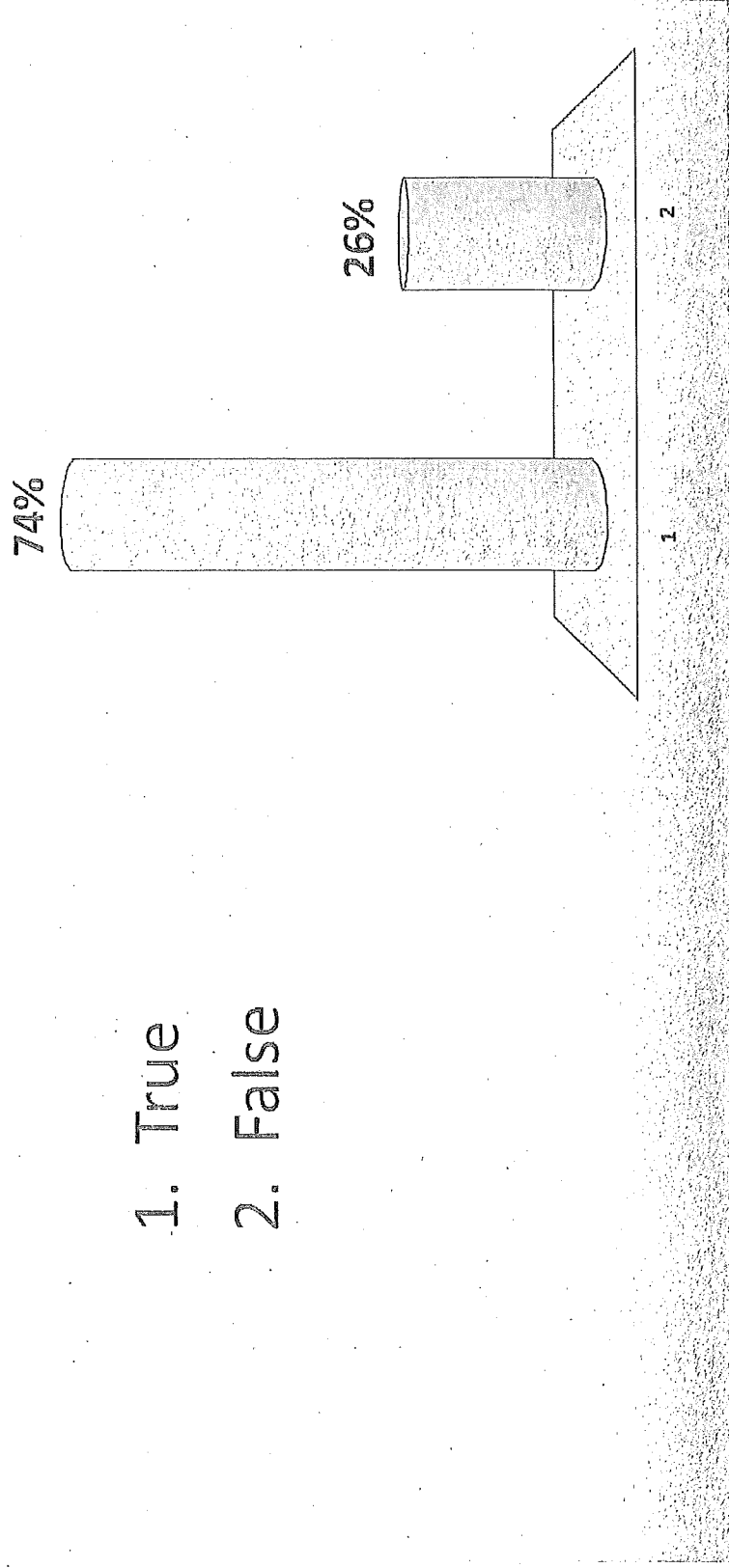

The following pages contain unofficial data results received during the four community meetings regarding the proposed Local Yalecrest Historic District. Questions given were not scientific, professionally formulated, or intended to constitute a vote. The results in the document are not indicative of a vote or a final decision and only represent a small portion of the entire area; the results are to gain general insight from the participating residents.

In a historic district you may be allowed to build an addition off the back of your house.

1. Generally true depending on the circumstance
2. True
3. False

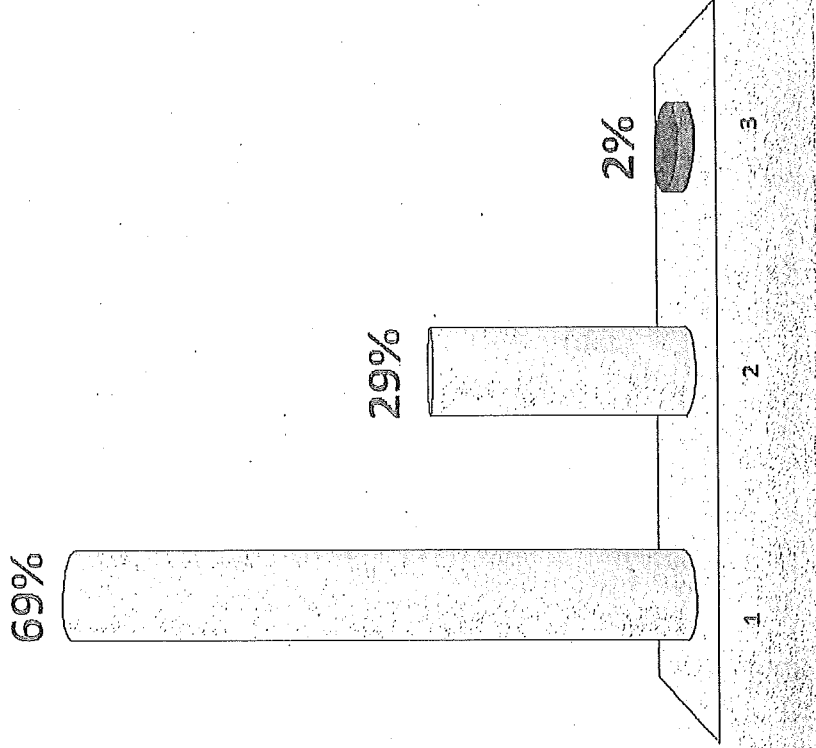

The following pages contain unofficial data results received during the four community meetings regarding the proposed Local Yalecrest Historic District. Questions given were not scientific, professionally formulated, or intended to constitute a vote. The results in the document are not indicative of a vote or a final decision and only represent a small portion of the entire area; the results are to gain general insight from the participating residents.

In most cases in a historic district you would not be allowed to build an addition to the side of your house.

1. True
2. False

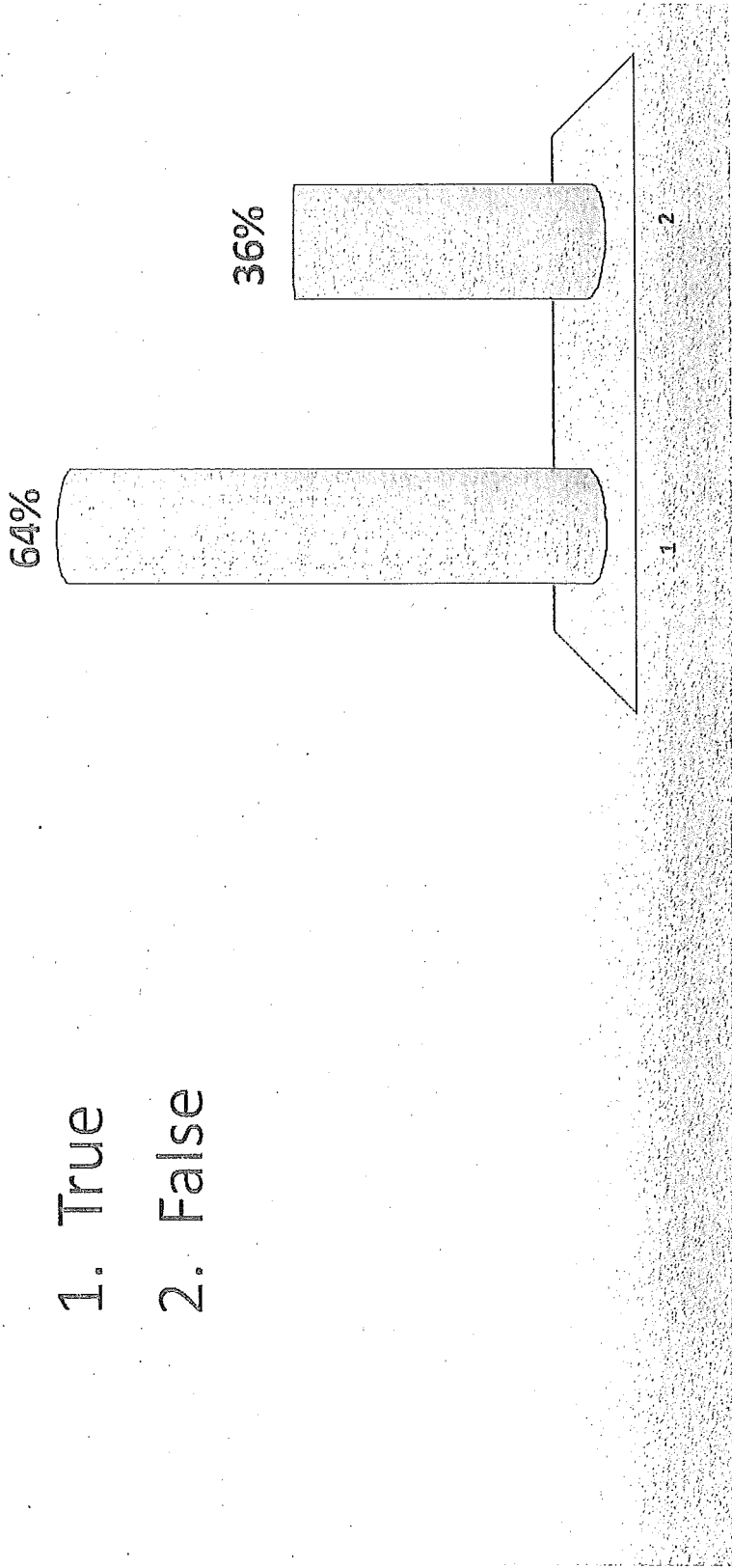

The following pages contain unofficial data results received during the four community meetings regarding the proposed Local Yalecrest Historic District. Questions given were not scientific, professionally formulated, or intended to constitute a vote. The results in the document are not indicative of a vote or a final decision and only represent a small portion of the entire area; the results are to gain general insight from the participating residents.

If your home is in a historic district, but is considered non-contributing, you will be required to make changes to your home so that it gains contributing status?

1. True
2. False

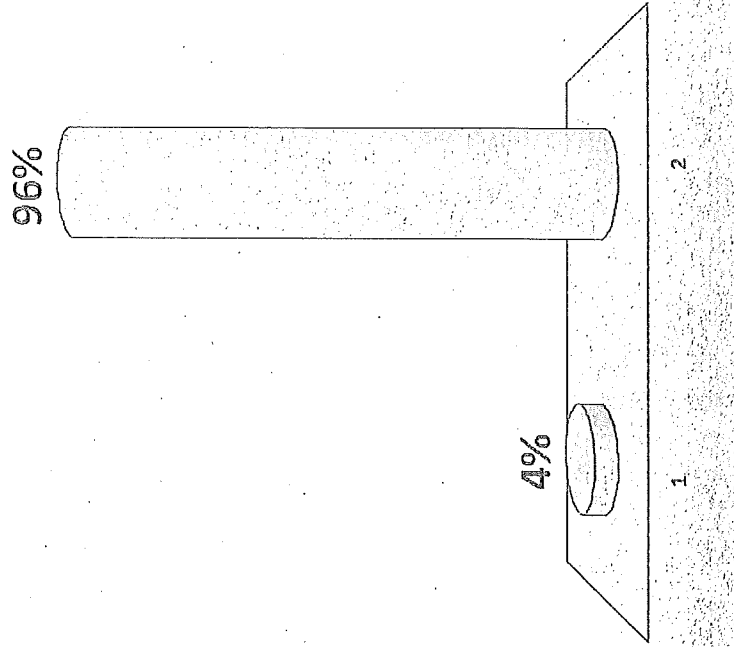

The following pages contain unofficial data results received during the four community meetings regarding the proposed Local Yalecrest Historic District. Questions given were not scientific, professionally formulated, or intended to constitute a vote. The results in the document are not indicative of a vote or a final decision and only represent a small portion of the entire area; the results are to gain general insight from the participating residents.

Living in a historic district will require you to obtain a certificate of appropriateness for any alterations you make on the interior of your home.

1. True
2. False

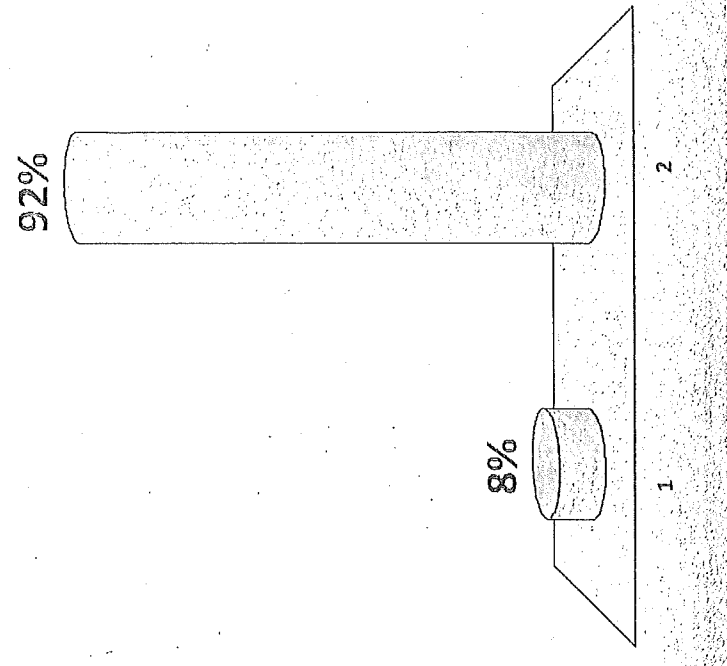

The following pages contain unofficial data results received during the four community meetings regarding the proposed Local Yalecrest Historic District. Questions given were not scientific, professionally formulated, or intended to constitute a vote. The results in the document are not indicative of a vote or a final decision and only represent a small portion of the entire area; the results are to gain general insight from the participating residents.

Shingles can only be replaced with historic materials.

1. True
2. False

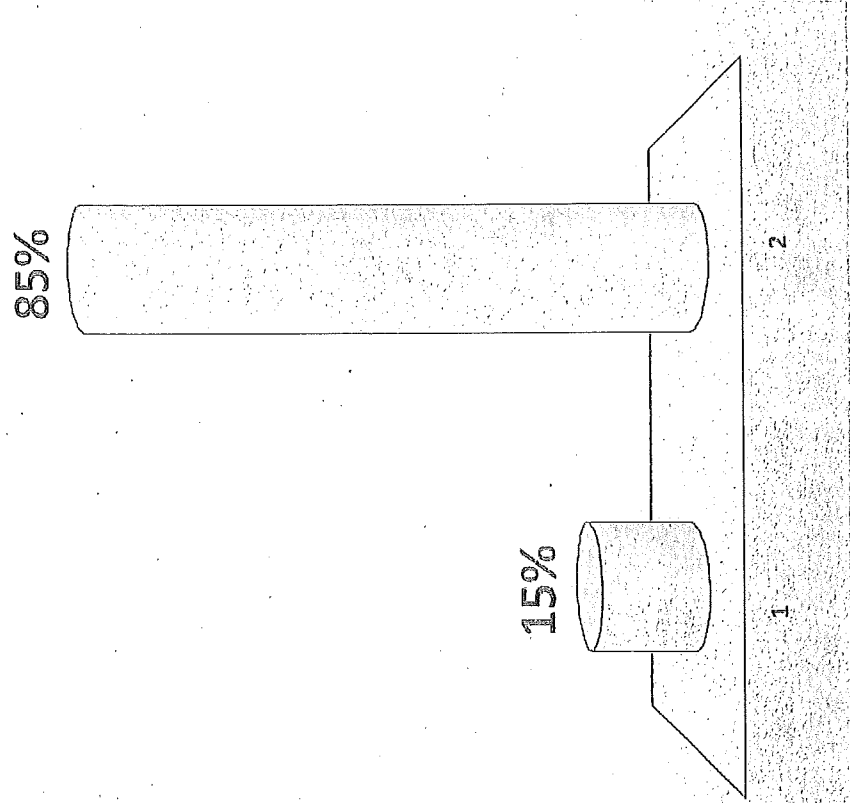

The following pages contain unofficial data results received during the four community meetings regarding the proposed Local Yalecrest Historic District. Questions given were not scientific, professionally formulated, or intended to constitute a vote. The results in the document are not indicative of a vote or a final decision and only represent a small portion of the entire area; the results are to gain general insight from the participating residents.

Vinyl windows are not allowed in a historic district.

1. True
2. False

62%

38%

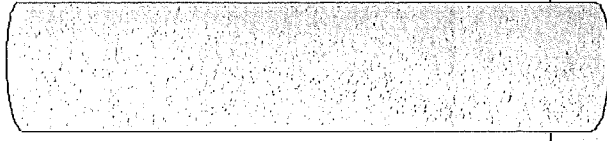

2

1

The following pages contain unofficial data results received during the four community meetings regarding the proposed Local Yalecrest Historic District. Questions given were not scientific, professionally formulated, or intended to constitute a vote. The results in the document are not indicative of a vote or a final decision and only represent a small portion of the entire area; the results are to gain general insight from the participating residents.

The Spring weather we're having is...?

1. Just perfect, wouldn't have it any other way!
2. Enough rain already!
3. That groundhog is full of crap!
4. I don't like the sun it give me freckles, more rain please!

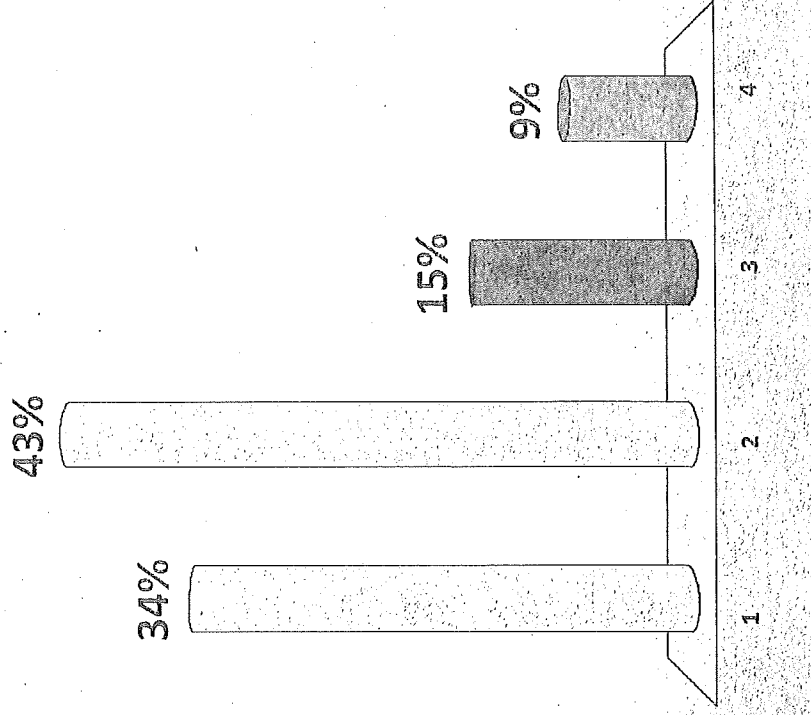

The following pages contain unofficial data results received during the four community meetings regarding the proposed Local Yalecrest Historic District. Questions given were not scientific, professionally formulated, or intended to constitute a vote. The results in the document are not indicative of a vote or a final decision and only represent a small portion of the entire area; the results are to gain general insight from the participating residents.

I would rather have one of the following, than another historic preservation discussion...

1. A root canal
2. A colonoscopy
3. Toenail fungus
4. The stomach Flu

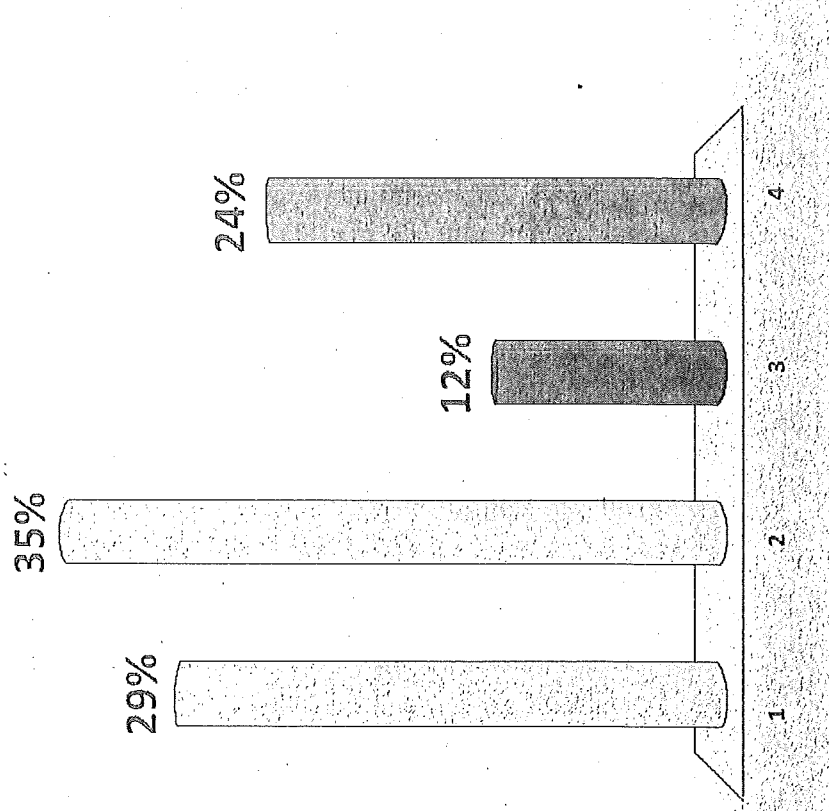

The following pages contain unofficial data results received during the four community meetings regarding the proposed Local Yalecrest Historic District. Questions given were not scientific, professionally formulated, or intended to constitute a vote. The results in the document are not indicative of a vote or a final decision and only represent a small portion of the entire area; the results are to gain general insight from the participating residents.

Who is the Mayor of Salt Lake City?

1. Chris Buttars
2. John English
3. Ralph Becker
4. Kevin Garn

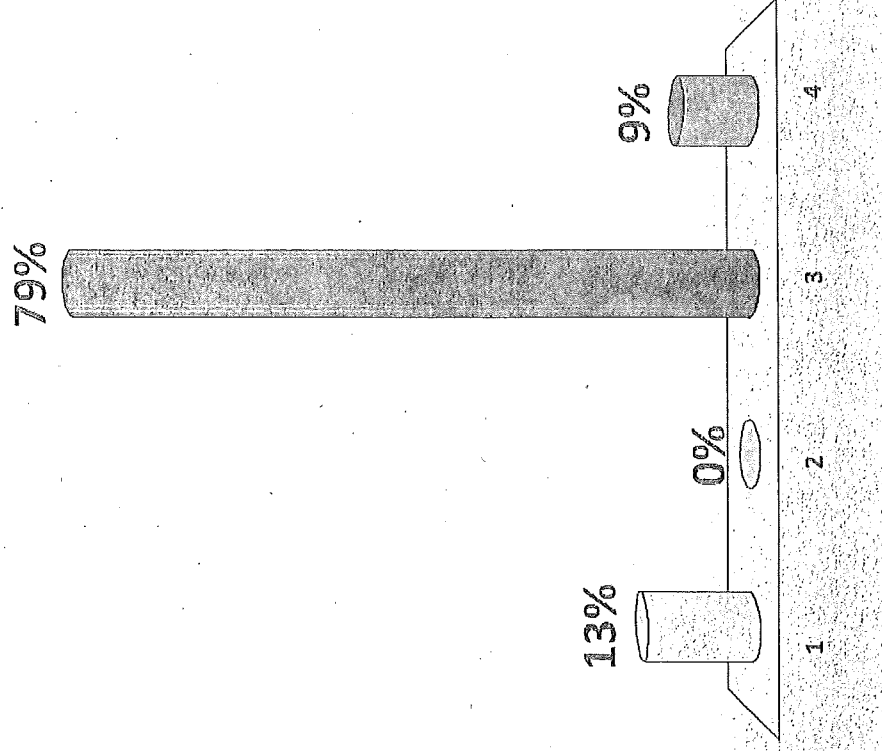

The following pages contain unofficial data results received during the four community meetings regarding the proposed Local Yalecrest Historic District. Questions given were not scientific, professionally formulated, or intended to constitute a vote. The results in the document are not indicative of a vote or a final decision and only represent a small portion of the entire area; the results are to gain general insight from the participating residents.

Do you feel that the City Council's approval of the Temporary zoning ordinance:

1. Caused residents to question the City's motives?
2. Was necessary in order to avoid tear-downs until a Historic District could be considered?
3. Was done secretly?
4. Was a chance to call a 6 month time out to determine the neighborhood's future?

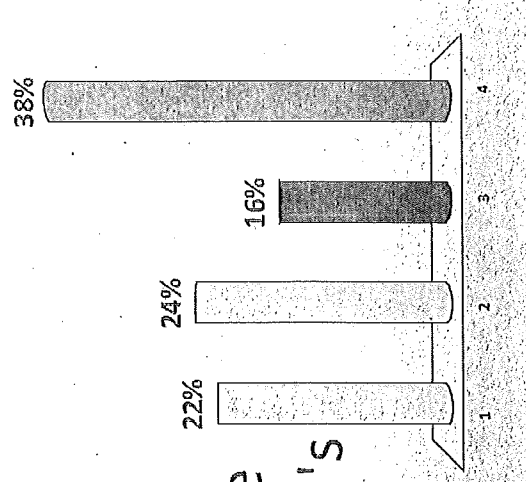

The following pages contain unofficial data results received during the four community meetings regarding the proposed Local Yalecrest Historic District. Questions given were not scientific, professionally formulated, or intended to constitute a vote. The results in the document are not indicative of a vote or a final decision and only represent a small portion of the entire area; the results are to gain general insight from the participating residents.

What characteristics of the neighborhood made you choose to live in Yalecrest?

1. architecture
2. location
3. schools
4. neighbors
5. historic character
6. potential home value

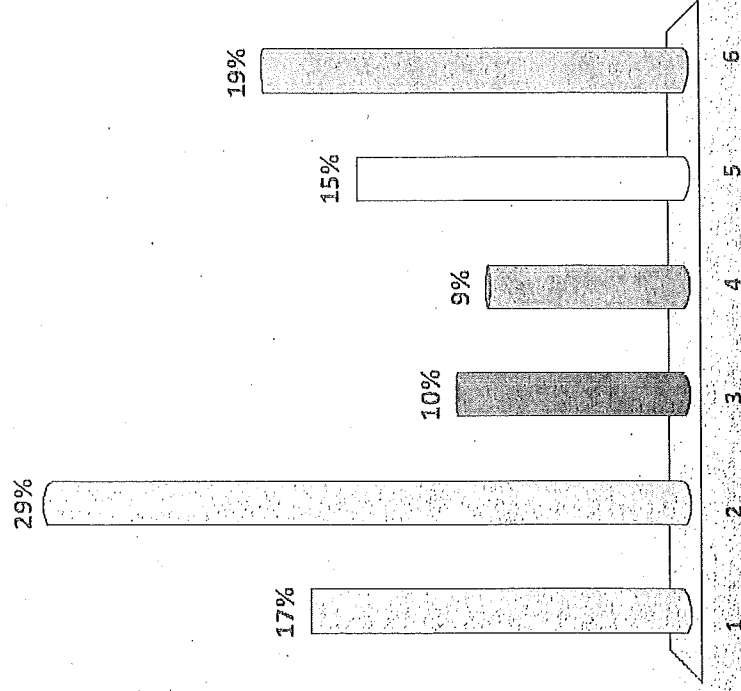

The following pages contain unofficial data results received during the four community meetings regarding the proposed Local Yalecrest Historic District. Questions given were not scientific, professionally formulated, or intended to constitute a vote. The results in the document are not indicative of a vote or a final decision and only represent a small portion of the entire area; the results are to gain general insight from the participating residents.

Which colors can you paint your home under Local Historic District regulations?

1. Red
2. Green
3. Brown
4. Gray
5. There is no restriction

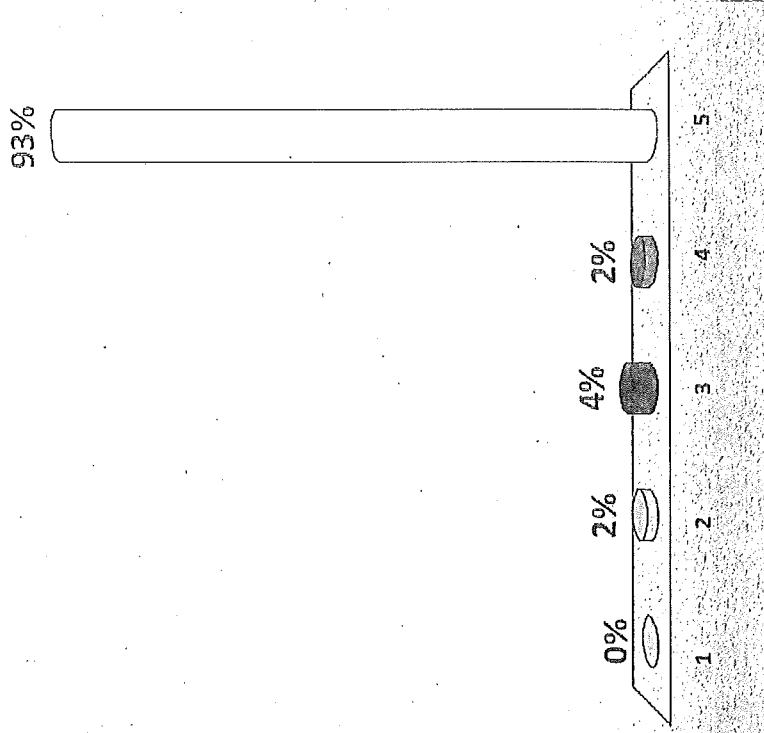

The following pages contain unofficial data results received during the four community meetings regarding the proposed Local Yalecrest Historic District. Questions given were not scientific, professionally formulated, or intended to constitute a vote. The results in the document are not indicative of a vote or a final decision and only represent a small portion of the entire area; the results are to gain general insight from the participating residents.

Additions are not allowed under Local Historic District regulations.

1. True
2. False

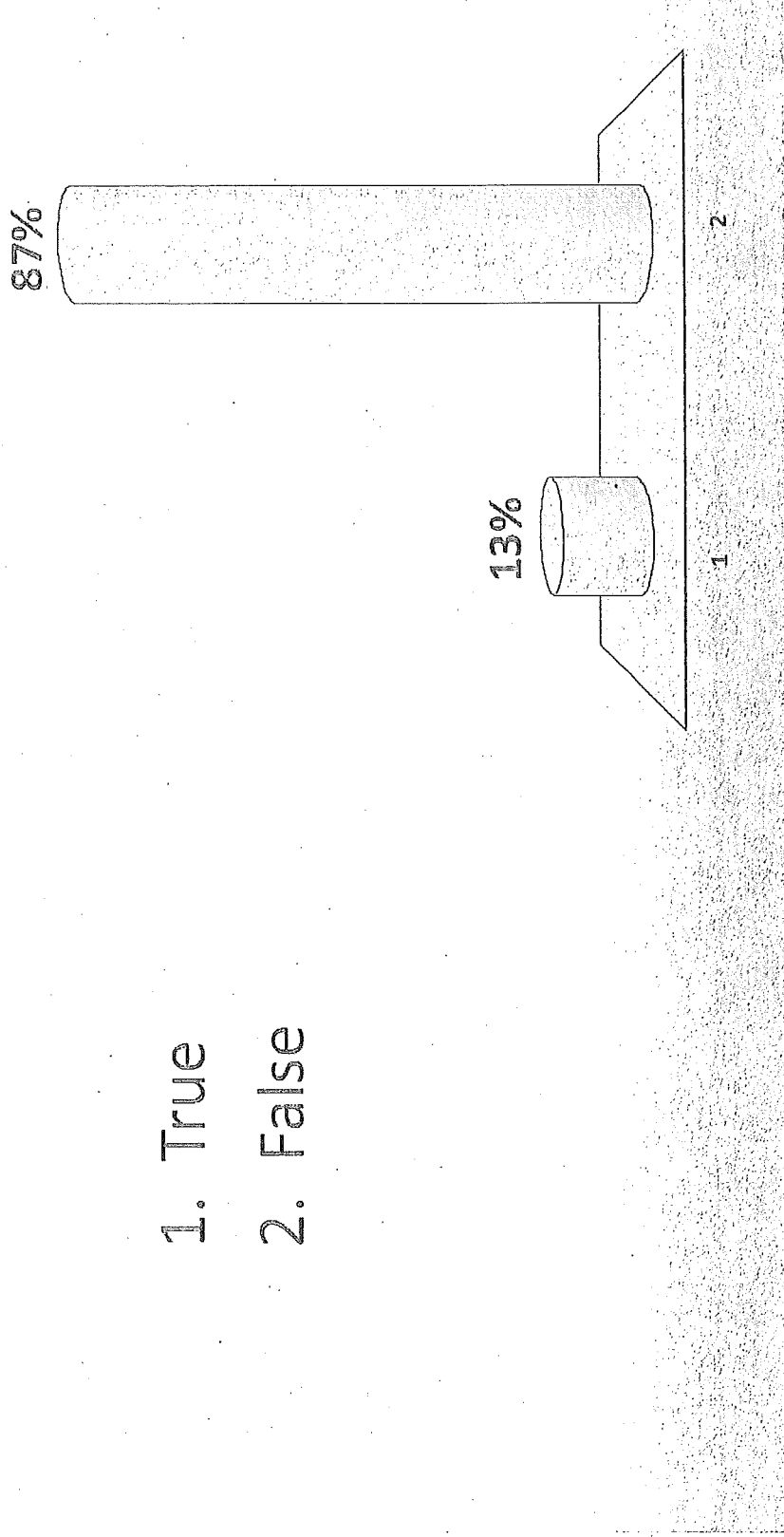

The following pages contain unofficial data results received during the four community meetings regarding the proposed Local Yalecrest Historic District. Questions given were not scientific, professionally formulated, or intended to constitute a vote. The results in the document are not indicative of a vote or a final decision and only represent a small portion of the entire area; the results are to gain general insight from the participating residents.

Do you feel like you have enough information to have a firm opinion on whether you would like to have a historic district or not?

1. Yes
2. No

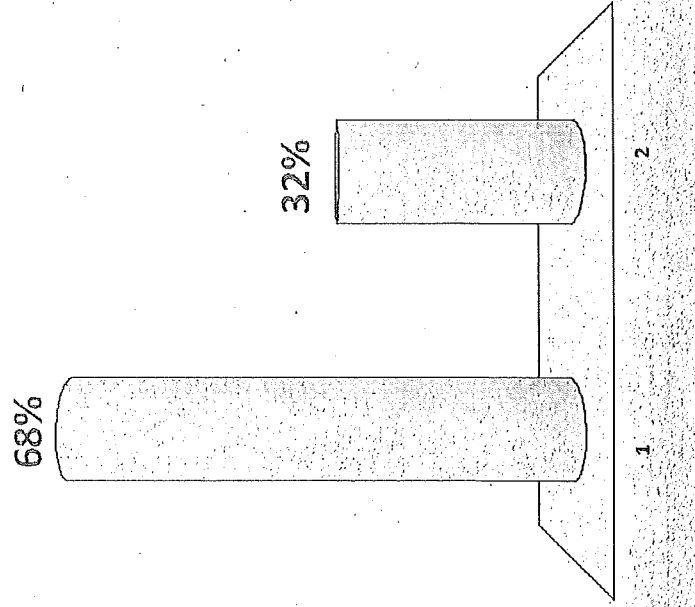

The following pages contain unofficial data results received during the four community meetings regarding the proposed Local Yatecrest Historic District. Questions given were not scientific, professionally formulated, or intended to constitute a vote. The results in the document are not indicative of a vote or a final decision and only represent a small portion of the entire area; the results are to gain general insight from the participating residents.

If you have expressed a 'yes' or 'no' opinion do you now feel like you fully understood the issue when you expressed that position?

1. Yes
2. No

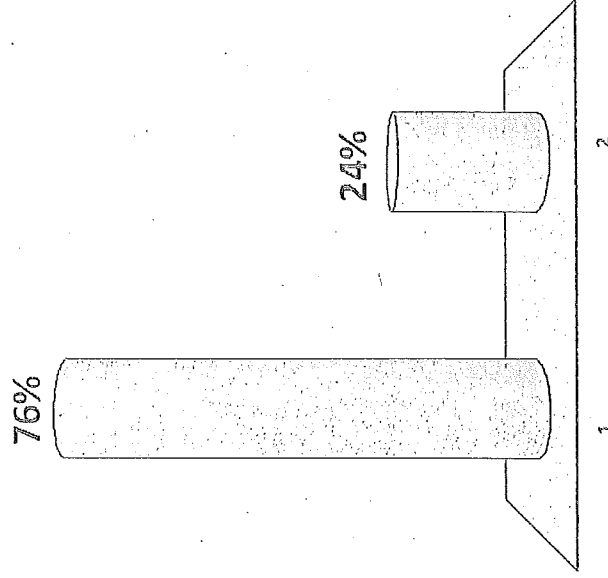

The following pages contain unofficial data results received during the four community meetings regarding the proposed Local Yalecrest Historic District. Questions given were not scientific, professionally formulated, or intended to constitute a vote. The results in the document are not indicative of a vote or a final decision and only represent a small portion of the entire area; the results are to gain general insight from the participating residents.

Stricter zoning rules could address neighborhood concerns.

1. Agree
2. Disagree

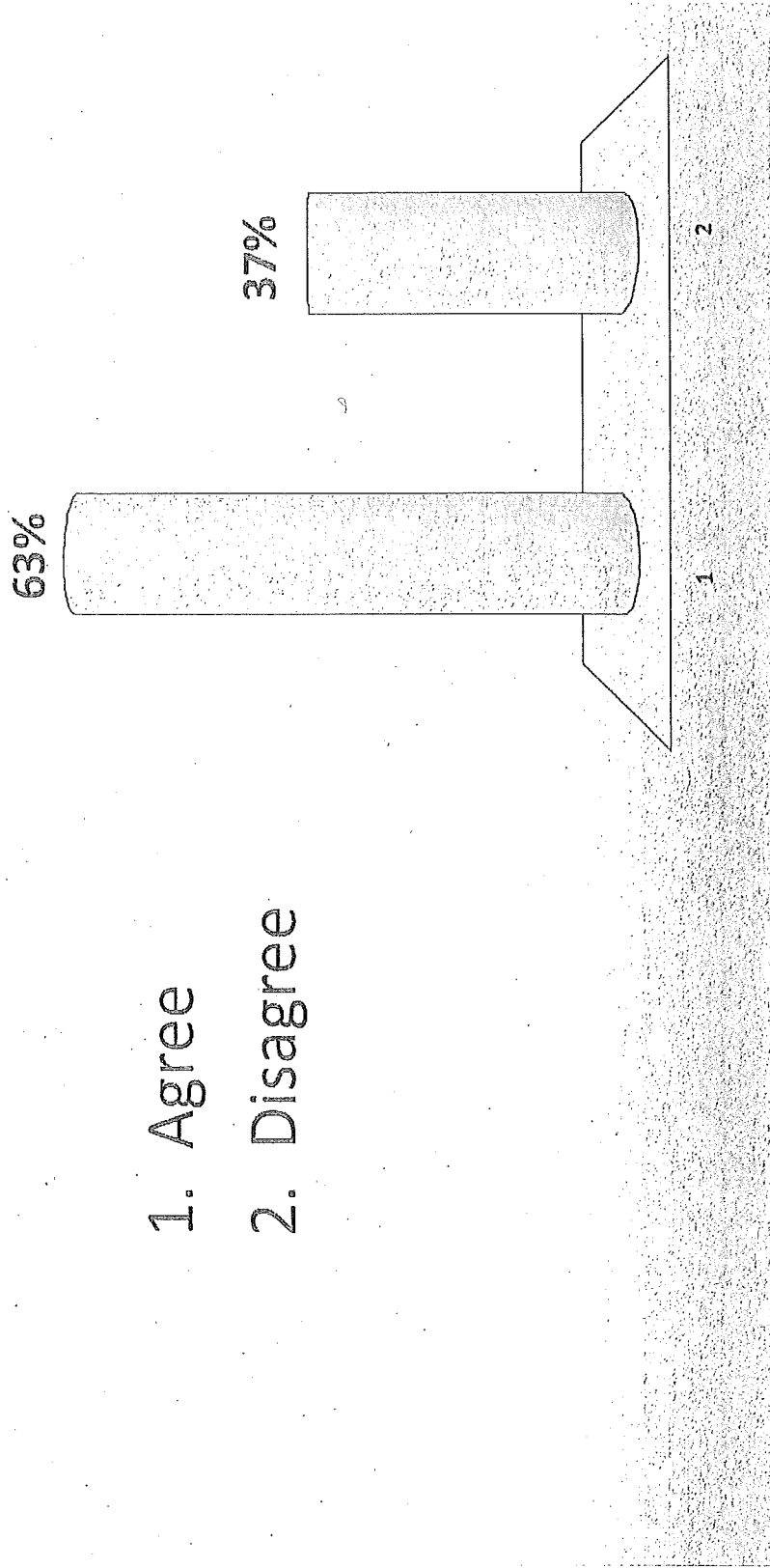

The following pages contain unofficial data results received during the four community meetings regarding the proposed Local Yalecrest Historic District. Questions given were not scientific, professionally formulated, or intended to constitute a vote. The results in the document are not indicative of a vote or a final decision and only represent a small portion of the entire area; the results are to gain general insight from the participating residents.

I believe we need the local historic district before the loss of more houses.

1. Agree
2. Disagree

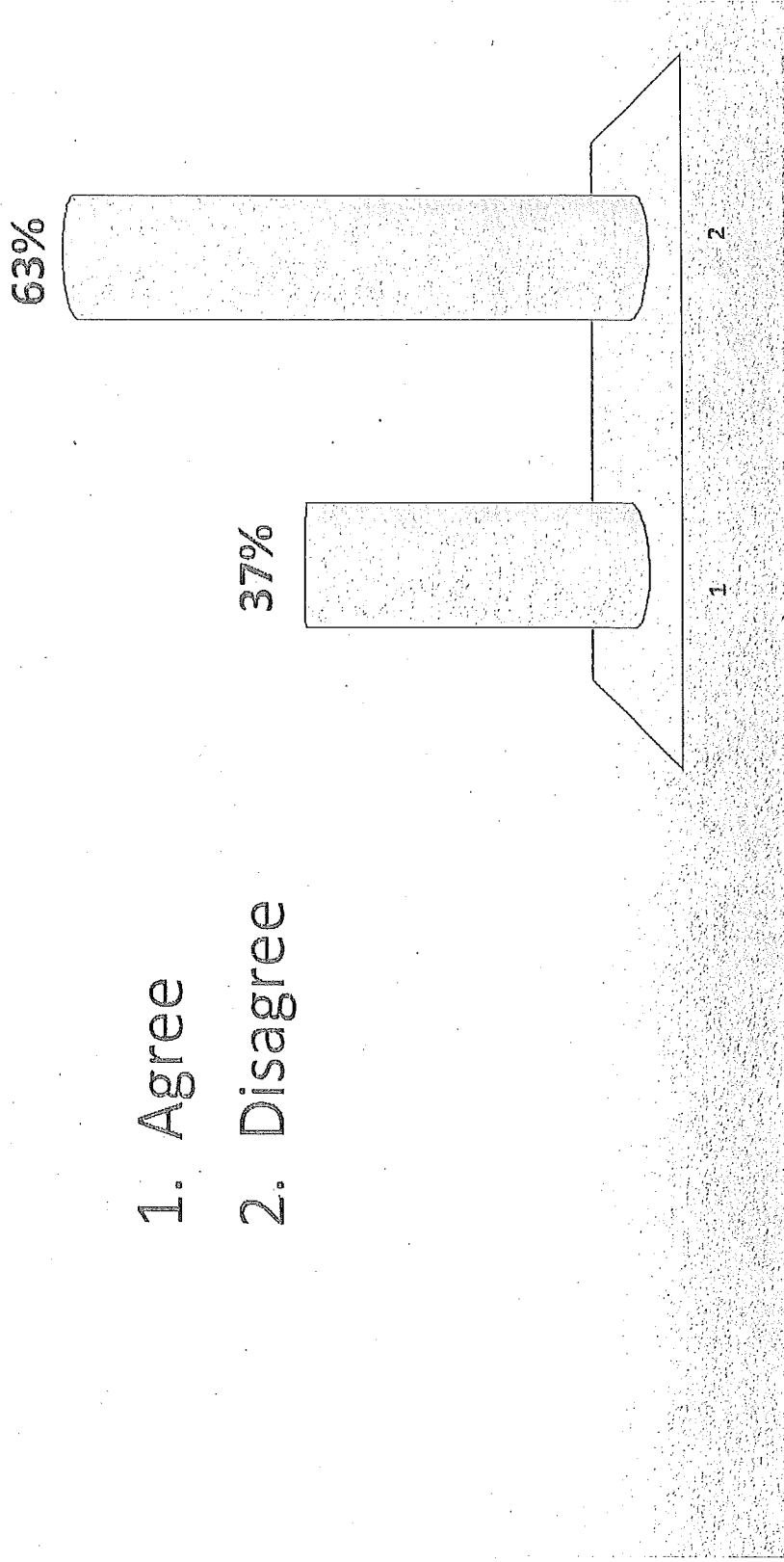

The following pages contain unofficial data results received during the four community meetings regarding the proposed Local Yalecrest Historic District. Questions given were not scientific, professionally formulated, or intended to constitute a vote. The results in the document are not indicative of a vote or a final decision and only represent a small portion of the entire area; the results are to gain general insight from the participating residents.

I believe the historic district would be too restrictive – we need other options to help.

1. Agree
2. Disagree

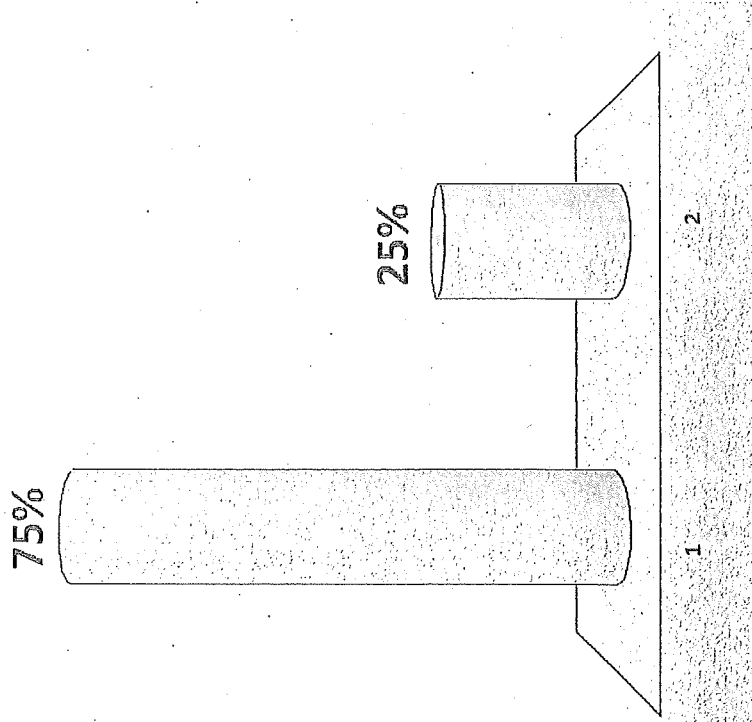

The following pages contain unofficial data results received during the four community meetings regarding the proposed Local Yalecrest Historic District. Questions given were not scientific, professionally formulated, or intended to constitute a vote. The results in the document are not indicative of a vote or a final decision and only represent a small portion of the entire area; the results are to gain general insight from the participating residents.

Pick three of the following characteristics which helped you choose to live in Yalecrest?

1. architecture
2. location
3. schools
4. neighbors
5. historic character
6. potential home value

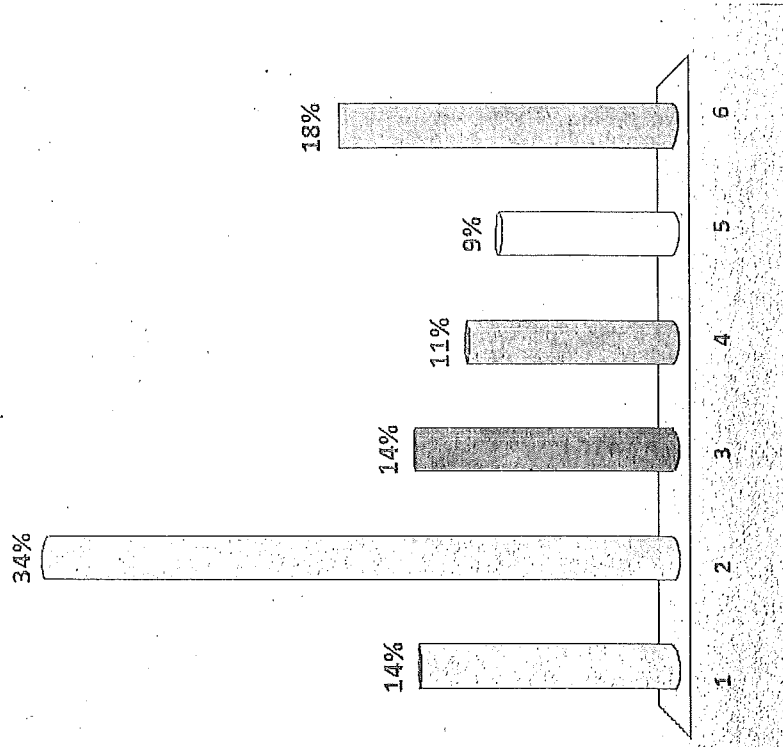

The following pages contain unofficial data results received during the four community meetings regarding the proposed Local Yalecrest Historic District. Questions given were not scientific, professionally formulated, or intended to constitute a vote. The results in the document are not indicative of a vote or a final decision and only represent a small portion of the entire area; the results are to gain general insight from the participating residents.

What is the appropriate balance for the neighborhood?

1. Maximum options and rights for property owners

2. Maximum options and rights as long as they don't disrupt the historic architecture design and character

3. Regulations that prevent demolitions

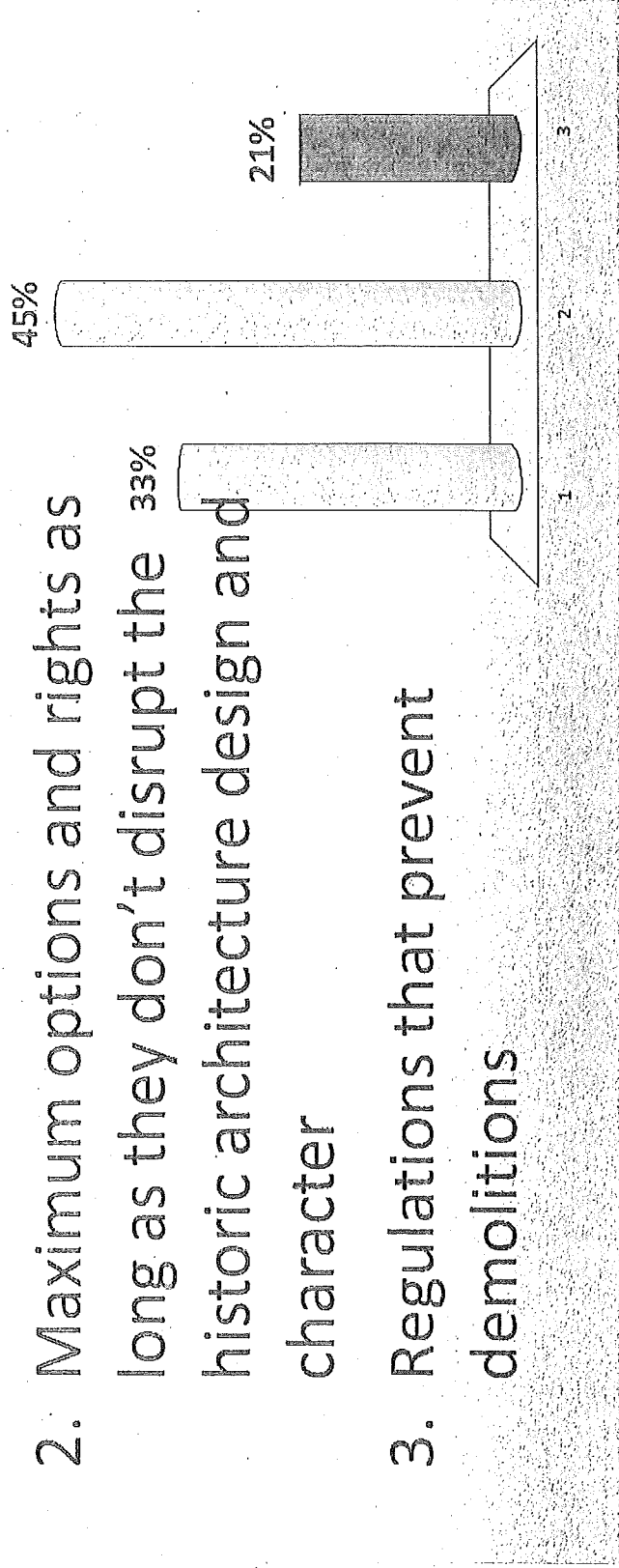

The following pages contain unofficial data results received during the four community meetings regarding the proposed Local Yalecrest Historic District. Questions given were not scientific, professionally formulated, or intended to constitute a vote. The results in the document are not indicative of a vote or a final decision and only represent a small portion of the entire area; the results are to gain general insight from the participating residents.

Please select all from the following list that apply.

1. Additions that block sunlight from abutting properties should not be allowed
2. All additions should be allowed
3. Additions and alterations should be allowed as long as they conform to the historic character of the home

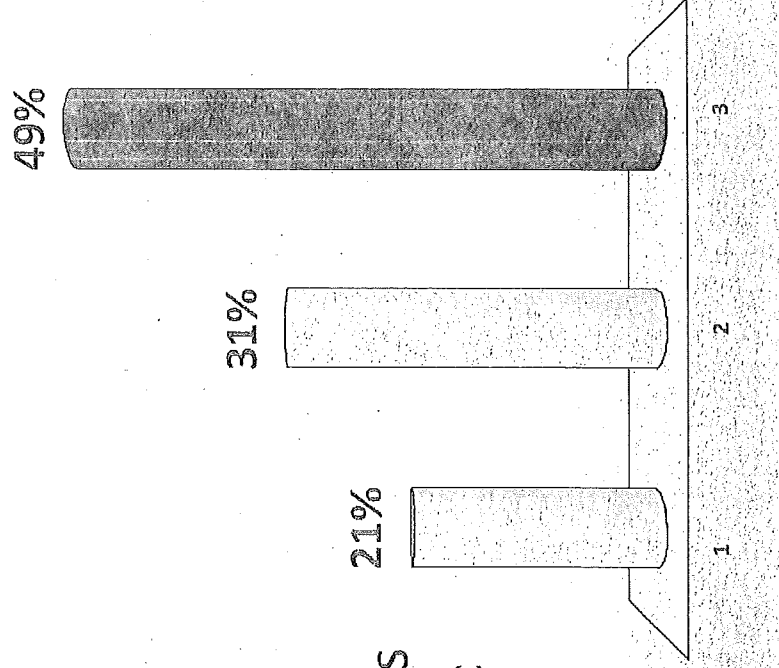

The following pages contain unofficial data results received during the four community meetings regarding the proposed Local Yalecrest Historic District. Questions given were not scientific, professionally formulated, or intended to constitute a vote. The results in the document are not indicative of a vote or a final decision and only represent a small portion of the entire area; the results are to gain general insight from the participating residents.

Each house in Yalecrest is a unique piece of art and the historic district is needed to preserve this "art".

1. Agree
2. Disagree

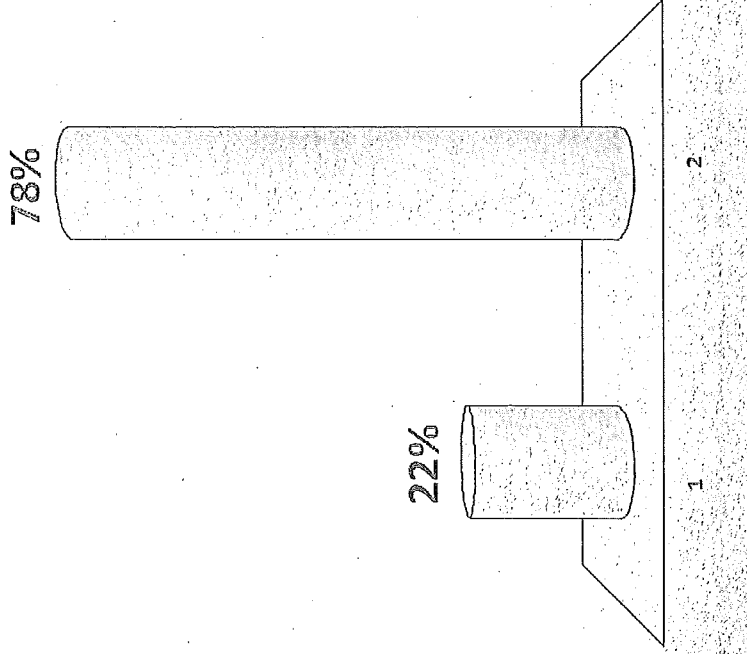

The following pages contain unofficial data results received during the four community meetings regarding the proposed Local Yalecrest Historic District. Questions given were not scientific, professionally formulated, or intended to constitute a vote. The results in the document are not indicative of a vote or a final decision and only represent a small portion of the entire area; the results are to gain general insight from the participating residents.

Which issue are you most concerned about?

1. Preservation of existing structures
2. Compatibility of structures in the neighborhood
3. Size of structures
4. Demolition of existing homes

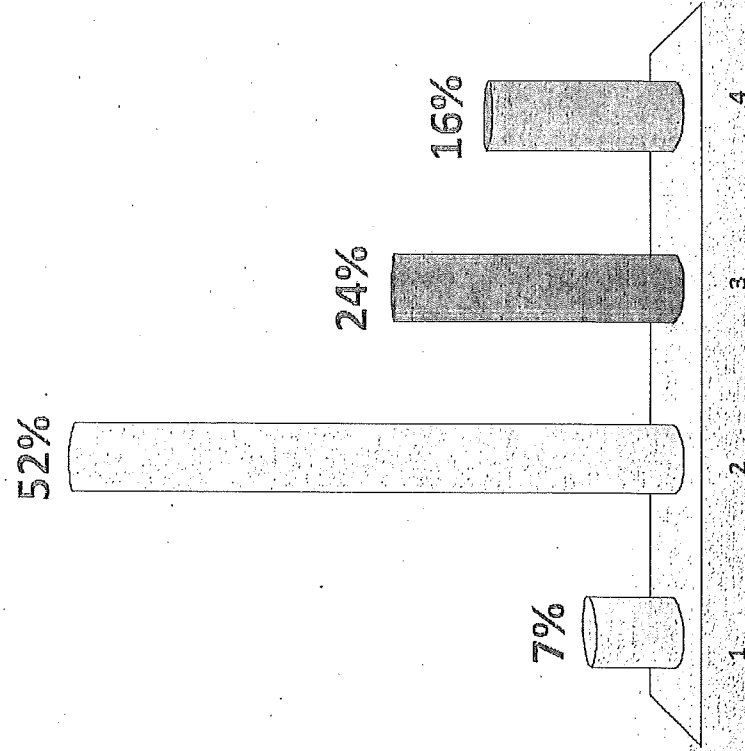

The following pages contain unofficial data results received during the four community meetings regarding the proposed Local Yalecrest Historic District. Questions given were not scientific, professionally formulated, or intended to constitute a vote. The results in the document are not indicative of a vote or a final decision and only represent a small portion of the entire area; the results are to gain general insight from the participating residents.

From which source have you received most of your information on this issue?

1. Neighbors
2. Community meetings
3. Social media
4. Emails from the City
5. News media
6. Other

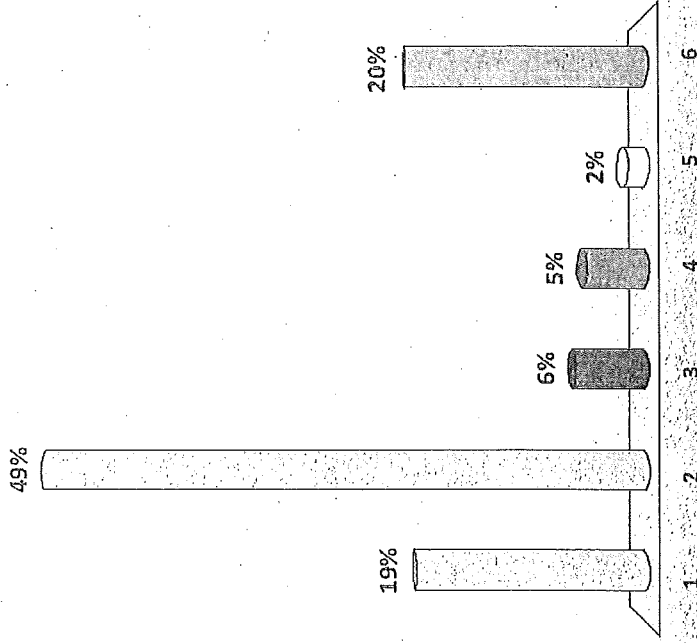

The following pages contain unofficial data results received during the four community meetings regarding the proposed Local Yalecrest Historic District. Questions given were not scientific, professionally formulated, or intended to constitute a vote. The results in the document are not indicative of a vote or a final decision and only represent a small portion of the entire area; the results are to gain general insight from the participating residents.

When you bought your home, did you intend to stay...

1. Short term
2. Long term
3. While looking for a home that fit our family's needs better

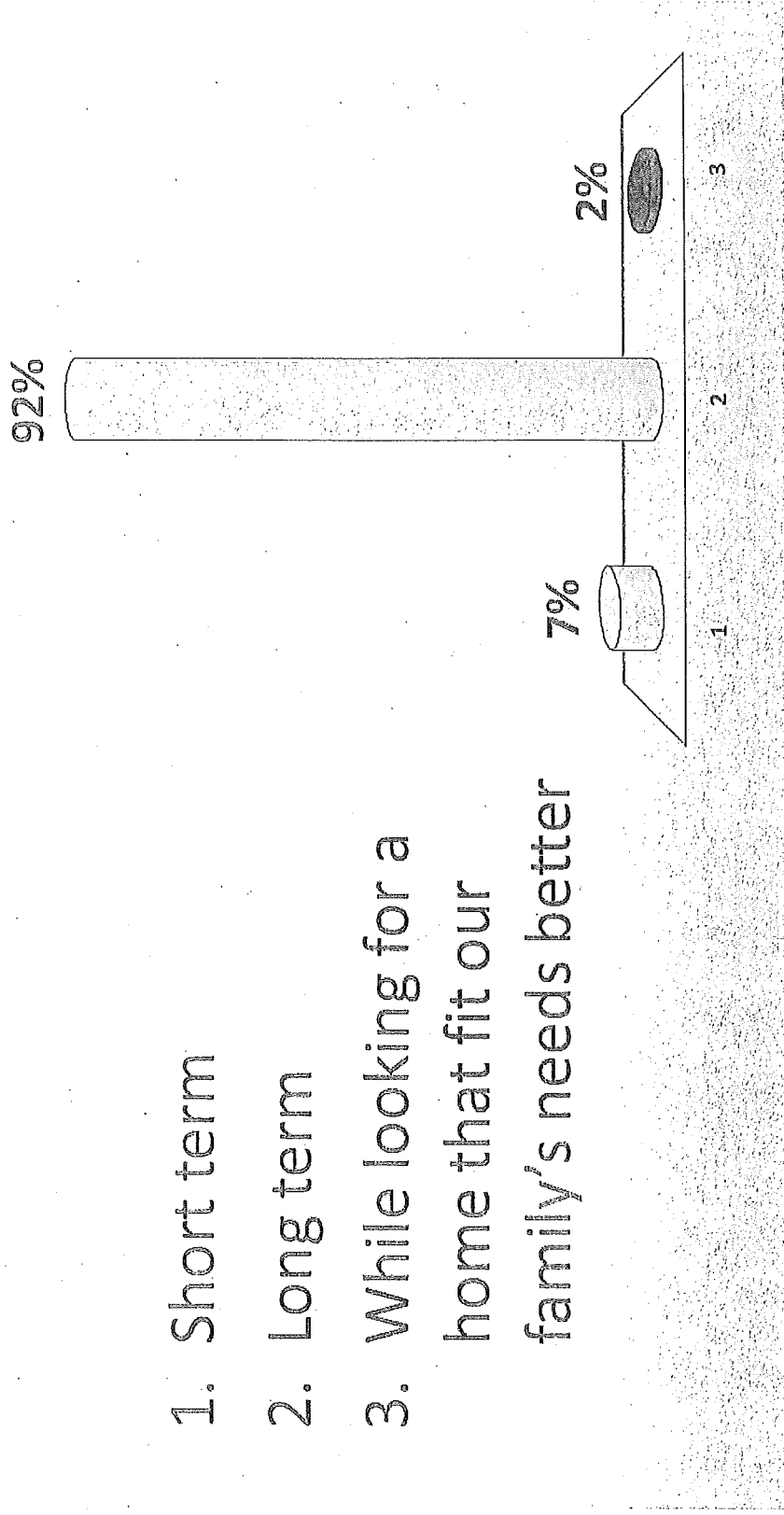

The following pages contain unofficial data results received during the four community meetings regarding the proposed Local Yalecrest Historic District. Questions given were not scientific, professionally formulated, or intended to constitute a vote. The results in the document are not indicative of a vote or a final decision and only represent a small portion of the entire area; the results are to gain general insight from the participating residents.

Do you feel uncomfortable expressing your opinion on this topic for any of the following reasons?

1. Difficult to understand
2. Divisive in community
3. Strong public opinion
4. Fear of being judged
5. Fear of reprisal
6. No I don't feel uncomfortable

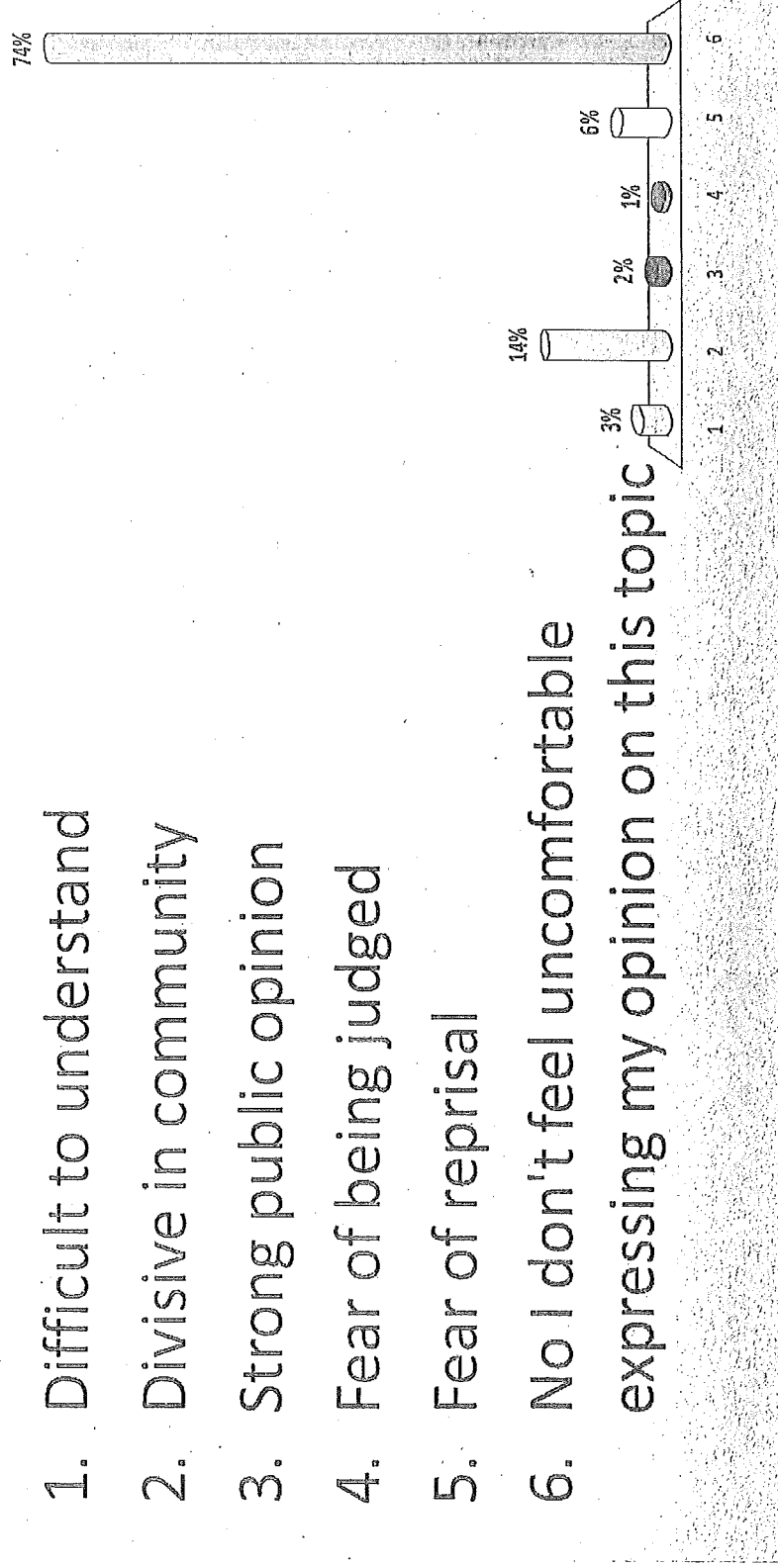

The following pages contain unofficial data results received during the four community meetings regarding the proposed Local Yalecrest Historic District. Questions given were not scientific, professionally formulated, or intended to constitute a vote. The results in the document are not indicative of a vote or a final decision and only represent a small portion of the entire area; the results are to gain general insight from the participating residents.

Do you feel like you have enough information to have a firm opinion on whether you would like to have a historic district or not?

1. Yes
2. No

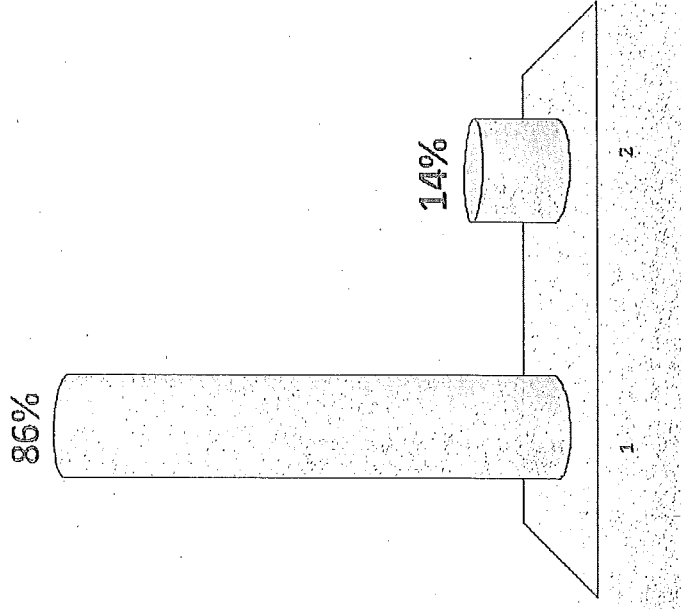

The following pages contain unofficial data results received during the four community meetings regarding the proposed Local Yalecrest Historic District. Questions given were not scientific, professionally formulated, or intended to constitute a vote. The results in the document are not indicative of a vote or a final decision and only represent a small portion of the entire area; the results are to gain general insight from the participating residents.

Have you expressed a 'yes' or 'no' opinion through one of the web sites or by contacting the City Council?

1. Yes
2. No

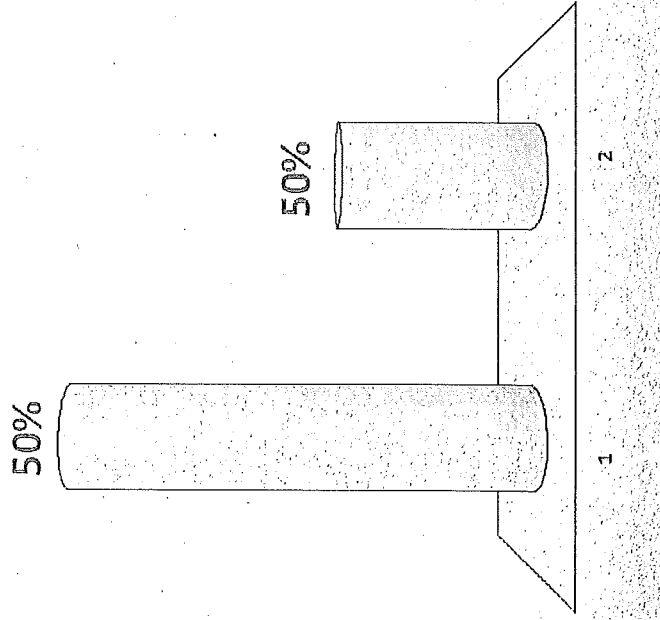

The following pages contain unofficial data results received during the four community meetings regarding the proposed Local Yalecrest Historic District. Questions given were not scientific, professionally formulated, or intended to constitute a vote. The results in the document are not indicative of a vote or a final decision and only represent a small portion of the entire area; the results are to gain general insight from the participating residents.

If you have expressed a 'yes' or 'no' opinion do you now feel like you fully understood the issue when you expressed that position?

1. Yes
2. No

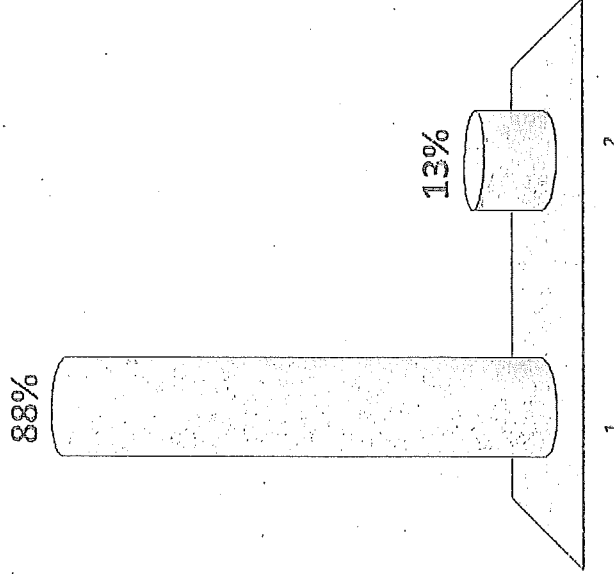

The following pages contain unofficial data results received during the four community meetings regarding the proposed Local Yalecrest Historic District. Questions given were not scientific, professionally formulated, or intended to constitute a vote. The results in the document are not indicative of a vote or a final decision and only represent a small portion of the entire area; the results are to gain general insight from the participating residents.

If you have submitted your opinion to the Council Office, has your opinion changed since then?

1. Yes
2. No

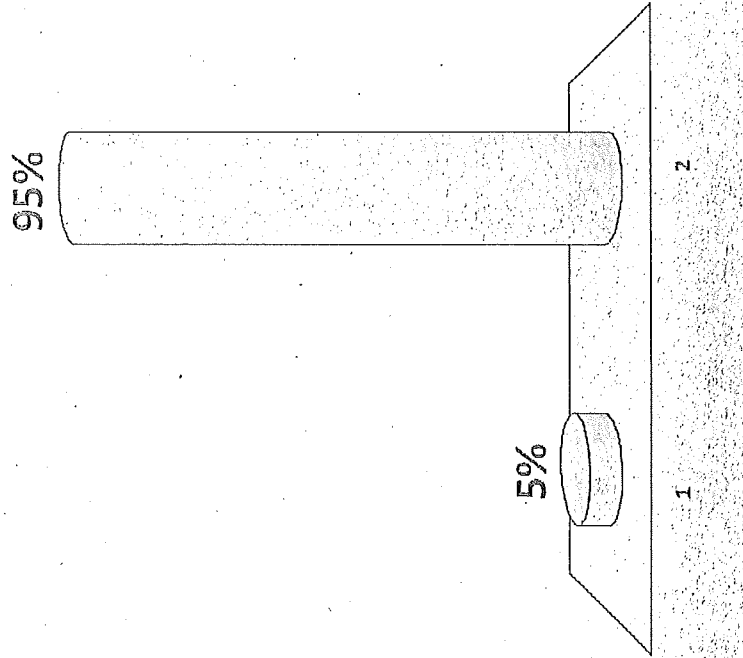

The following pages contain unofficial data results received during the four community meetings regarding the proposed Local Yalecrest Historic District. Questions given were not scientific, professionally formulated, or intended to constitute a vote. The results in the document are not indicative of a vote or a final decision and only represent a small portion of the entire area; the results are to gain general insight from the participating residents.

Most of the concerns in the neighborhood are demolitions & remodels that push the limits of current law & disregard the style & scale of the neighborhood.

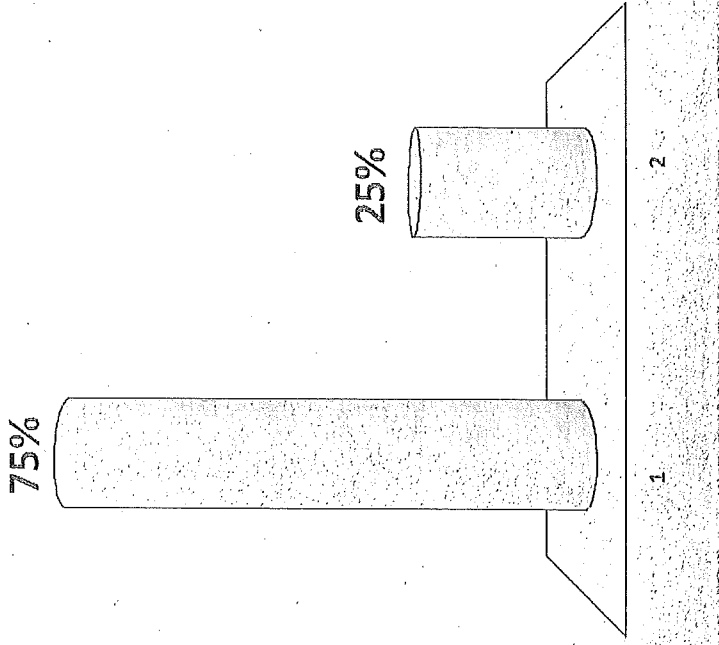

- 1. Agree
- 2. Disagree

The following pages contain unofficial data results received during the four community meetings regarding the proposed Local Yalecrest Historic District. Questions given were not scientific, professionally formulated, or intended to constitute a vote. The results in the document are not indicative of a vote or a final decision and only represent a small portion of the entire area; the results are to gain general insight from the participating residents.

I would like to retain the character of the neighborhood but I do not know if a local historic district is the right way to do this.

- 1. Agree
- 2. Disagree

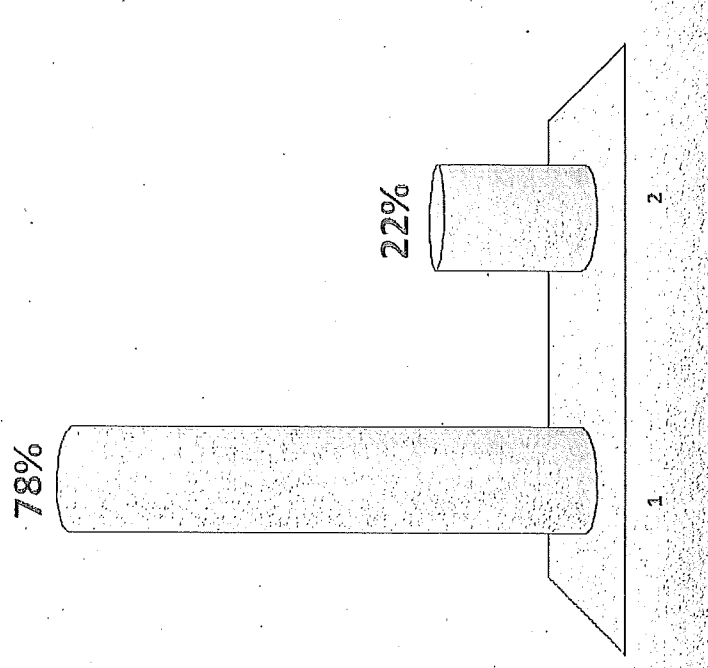

The following pages contain unofficial data results received during the four community meetings regarding the proposed Local Yalecrest Historic District. Questions given were not scientific, professionally formulated, or intended to constitute a vote. The results in the document are not indicative of a vote or a final decision and only represent a small portion of the entire area; the results are to gain general insight from the participating residents.

I believe we need the local historic district before the loss of more houses.

1. Agree
2. Disagree

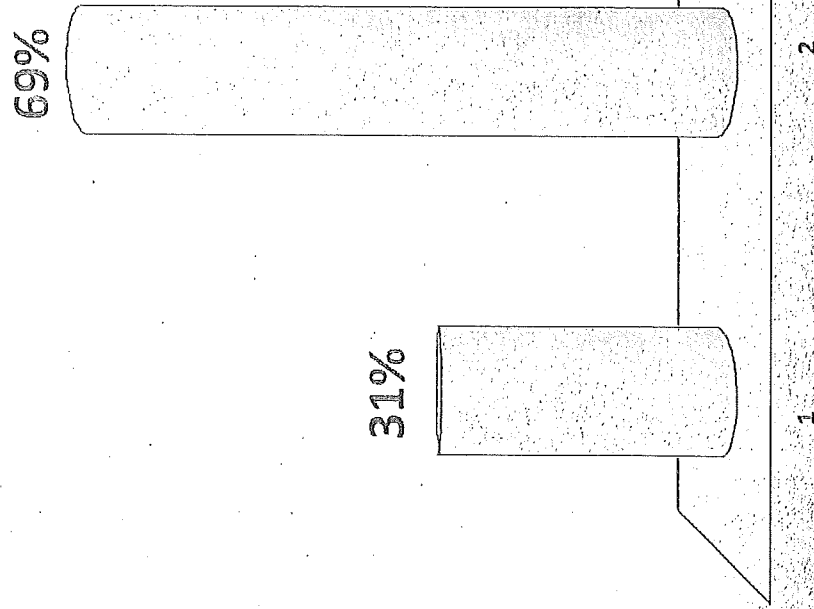

The following pages contain unofficial data results received during the four community meetings regarding the proposed Local Yalecrest Historic District. Questions given were not scientific, professionally formulated, or intended to constitute a vote. The results in the document are not indicative of a vote or a final decision and only represent a small portion of the entire area; the results are to gain general insight from the participating residents.

The historic district would be too restrictive – I believe we need other options to help.

1. Agree
2. Disagree

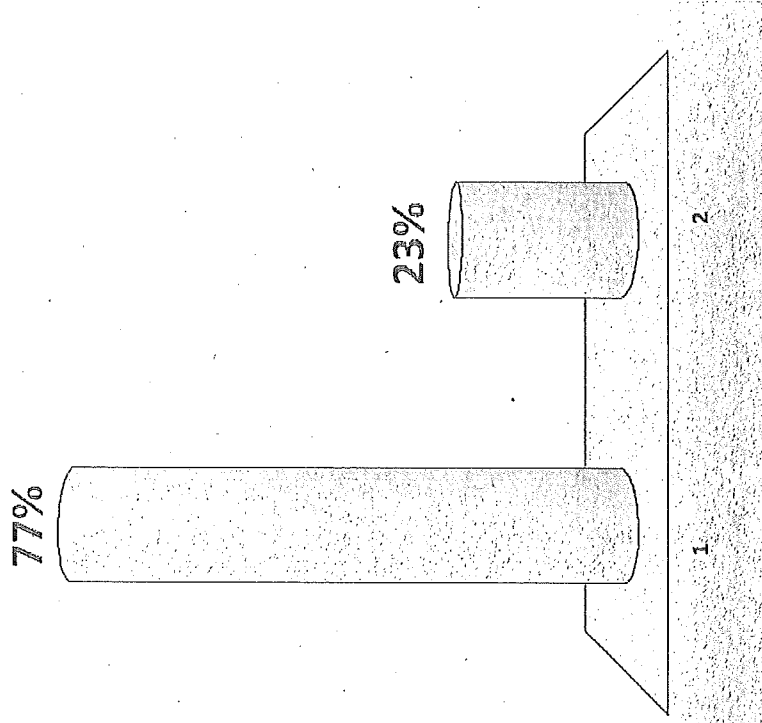

The following pages contain unofficial data results received during the four community meetings regarding the proposed Local Yalecrest Historic District. Questions given were not scientific, professionally formulated, or intended to constitute a vote. The results in the document are not indicative of a vote or a final decision and only represent a small portion of the entire area; the results are to gain general insight from the participating residents.

Summary of Community Meetings

Attachment I
To YCPRR Application

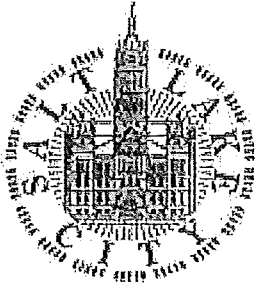

SALT LAKE CITY CORPORATION

Buzz Center

451 South State Street, Room 215 Phone: (801) 535-7700
P.O. Box 145471 Fax : (801) 535-7750
Salt Lake City, Utah 84114

Date: Oct 06, 2010

PLANNING COMMISSION

111 E BROADWAY SUITE 900, PO BOX 4050
SALT LAKE CITY, UT 84110

Project Name: YALECREST INFILL OVERLAY DISTRICT TEXT AMENDMENT

Project Address:

Detailed Description:

Description	Qty	Dept	C Ctr	Obj	Amount		
					Invoice	Paid	Due
Invoice Number: 797436							
Filing Fee (1	06	00900	125111	\$885.92		
Total for invoice 797436					\$885.92		\$885.92
Total for PLNPCM2010-00665					\$885.92		\$885.92

OFFICE USE ONLY
Intake By: AJ1631

CAP ID #
PLNPCM2010-00665
Total Due: \$885.92

www.slcpermits.com

Salt Lake City Treasurer

Rcpt# 1228200
PL PLNPCM2010-00665 CK
\$885.92 10/7/2010